



Artisan Technology Group is your source for quality new and certified-used/pre-owned equipment

- FAST SHIPPING AND DELIVERY
- TENS OF THOUSANDS OF IN-STOCK ITEMS
- EQUIPMENT DEMOS
- HUNDREDS OF MANUFACTURERS SUPPORTED
- LEASING/MONTHLY RENTALS
- ITAR CERTIFIED SECURE ASSET SOLUTIONS

SERVICE CENTER REPAIRS

Experienced engineers and technicians on staff at our full-service, in-house repair center

*InstraView*SM REMOTE INSPECTION

Remotely inspect equipment before purchasing with our interactive website at www.instraview.com ↗

WE BUY USED EQUIPMENT

Sell your excess, underutilized, and idle used equipment. We also offer credit for buy-backs and trade-ins. www.artisanng.com/WeBuyEquipment ↗

LOOKING FOR MORE INFORMATION?

Visit us on the web at www.artisanng.com ↗ for more information on price quotations, drivers, technical specifications, manuals, and documentation

Contact us: (888) 88-SOURCE | sales@artisanng.com | www.artisanng.com

YASNAC i80

CNC SYSTEM FOR MACHINE TOOLS

MAINTENANCE MANUAL

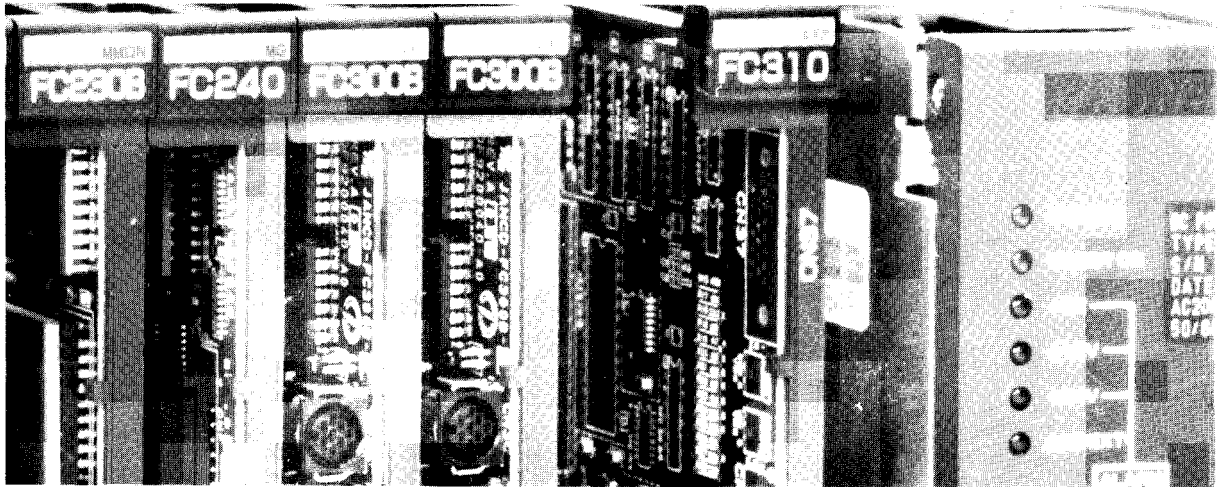

Before initial operation, read this manual thoroughly and retain for future reference.



YASKAWA

This manual is primarily intended to give operators maintenance instructions for YASNAC i80.

The information contained in manual does not provide all details to be met concerning maintenance and troubleshooting. If uncertainties be encountered for particular maintenance operation, refer to following YASNAC i80 documents for additional the information:

- YASNAC i80 PLC SYSTEM (T OE-C843-11.1)
- YASNAC i80M SPECIFICATIONS (SIE-C843-11.30)
- YASNAC i80L SPECIFICATIONS (S IE-C843-11.20)
- YASNAC i80M INSTRUCTION MANUAL (T OE-C843-11.30)
- YASNAC i80M INSTRUCTION MANUAL APPENDIX (TOE-C843-11.31)
- YASNAC i80L INSTRUCTION MANUAL (T OE-C843-11.20)
- YASNAC i80L INSTRUCTION MANUAL APPENDIX (TOE-C843-11.21)
- YASNAC i80 CONNECTING MANUAL (T OE-C843-11.5)

CONTENTS

1	OUTLINE	1
2	ROUTINE INSPECTION SCHEDULE	57
3	MAINTENANCE INSTRUMENTS	67
4	TROUBLESHOOTING	69
5	ADJUSTMENTS UPON INSTALLATION	135
6	MODULE/UNIT REPLACEMENT PROCEDURE ...	143
7	SETTING AND ADJUSTMENT OF EACH MODULE	197
8	OPERATIONS OF FIXED FILES . . .	203



CONTENTS

	Page
1. OUTLINE.....	1
1.1 COMPONENTS AND INTERCONNECTIONS	2
1.2 COMPONENTS.....	11
2. ROUTINE INSPECTION SCHEDULE.....000.....	57
2.1 ROUTINE INSPECTION	58
2.2 TAPE READER MAINTENANCE	59
2.3 CONTROL PANEL	60
2.4 AC SERVOMOTOR.....	62
2.5 BATTERY	63
3. MAINTENANCE INSTRUMENTS	67
4. TROUBLESHOOTING	69
4.1 TROUBLE Identification	71
4.1.1 RECOGNITION OF TROUBLE STATUS.....	71
4.1.2 RECOGNITION OF NC SYSTEM.....	72
4.2 TROUBLESHOOTING BY ALARM CODES.....	77
4.2.1 DISPLAY METHOD.....	77
4.2.1.1 ALARM INDICATION JOB	79
4.2.2 ALARMS 0010 AND 0011 (PARITY ERROR).....	82
4.2.3 ALARMS 0016, 0017, 0018, 9016, 9017 AND 9018 (RS-232C ERROR)0...	83
4.2.4 ALARM 1099 (TEMPERATURE ALARM INSIDE THE PANEL)	88
4.2.5 ALARMS, 2061 TO 2068 (ZERO POINT RETURN AREA ERROR).....	89
4.2.6 ALARMS 2071 TO 2078, 2081 TO 2088 (REFERENCE POINT RETURN AREA ERROR)	90
4.2.7 ALARMS 2101 TO 2108 (P-SET ERROR)	91
4.2.8 ALARM 3000 (SERVO UNREADY)	92
4.2.9 ALARM 3001 (CONTROL NOT READY).....	92
4.2.10 ALARM 3002 (EMERGENCY STOP)	93
4.2.11 ALARMS 3041 TO 3048 (EXCESSIVE POSITION LAG)	94
4.2.12 ALARMS 3051 TO 3054 (EXCESSIVE POSITION LAG)	95
4.2.13 ALARMS 3061 TO 3068 (MOTOR OVERLOAD).....	96
4.2.14 ALARMS 3081 TO 3088 (PG DISCONNECTION ERROR)	96
4.2.15 ALARMS 3091 TO 3094 (SPINDLE PG DISCONNECTION ERROR)	97
4.2.16 ALARMS 3121 TO 3128 (EXCESSIVE SPEED).....	97
4.2.17, -ALARMS 3141 TO 3148 (PREVENTION OF UNCONTROLLED RUNNING) .	98
4.2.18 ALARMS 3161 TO 3168 (ABSOLUTE ERRORS).....	98
4.2.19 ALARMS 3181 TO 3188 (POSITION ERRORS).....	99

CONTENTS (Cent'd)

	Page
4.2.20 ALARMS 3201 TO 3208 (SERVODRIVE UNIT COMMUNICATION ERRORS).....	99
4.2.21 ALARMS 3301 T03305 (OVERCURRENT)	100
4.2.22 ALARMS 3311 T03315(MCCB TRIP)	100
4.2.23 ALARMS 3321 TO 3325 (REGENERATIVE ERROR)	100
4.2.24 ALARMS 3331 T03335 (OVERVOLTAGE)	101
4.2.25 ALARMS 3341 T03345 (UNDERVOLTAGE)	101
4.2.26 ALARMS 3351 TO 3355 (HEAT SINK OVERHEAT)	101
4.2.27 ALARMS 3361 TO 3365 (WIRE BREAK IN CURRENT INSTRUCTION CABLE)	102
4.2.28 ALARMS 3371 T03375 (MISSING PHASE)	102
4.3 TROUBLESHOOTING WITHOUT ALARM CODES.....	103
4.3.1 POWER CANNOT RESUPPLIED..	103
4.3.2 SOLUTION TO ERRORS DETECTED IN SELF-DIAGNOSIS . . .0....	104
4.3.2.1 SELF-DIAGNOSIS FUNCTIONS.....	104
4.3.2.2DETAILSOFFUNCTION.....	105
4.3.3 CRT SCREEN DOES NOT DISPLAY	113
4.3.4 HANDLE MODE OPERATION FAULTY.....	113
4.3.5 MANuALJOG M0DE0PERATI0N Faulty	115
4.3.6 MANUAL RAPID MODE OPERATION FAULTY.....	117
4.3.7 MANUAL ZERO RETURN OPERATION FAULTy	119
4.3.8 CYCLE START FAILURE	120
4.3.9 OPERATION IS NOT AVAILABLE WITH GO1, G02, OR G03 .. 0.0...	121
4.3.10 SPINDLE DOES NOT ROTATE	122
4.3.11 9" CRT SCREEN IS DARK	123
4.3.12 EDIT DOES NOT FUNCTION	124
4.3.13 FIN WAIT OCCURS BY SPINDLE RELATED INSTRUCTION	125
4.3.14 SKIP FUNCTION (G31) OPERATION Failure	126
4.3.15 TAPE MODE DOES NOT FUNCTION	127
4.4 POWER SUPPLY VOLTAGE CHECK	128
4.4.1 CHECK AT POWER SUPPLY VOLTAGE	128
4.4.2 INDICATION OF LAMP OF POWER SUPPLY UNIT	129
4.4.3 CHECK DC POWER SUPPLY VOLTAGE	129
4.5 STATUS DISPLAY BY SELF-DIAGNOSIS FUNCTION (DGN).....	130
4.5.1 OUTLINE OF DISPLAY	130
4.5.2 DISPLAYING INPUT/OUTPUT SIGNALS.....	131
--	
5. ADJUSTMENTS UPON INSTALLATION.....	135

CONTENTS (Cent'd)

	Page
6. MOD ULE/UNIT REPLACEMENT PROCEDURE	143
6.1 NC RACK	144
6.1.1 POWER SUPPLY UNIT (MODEL CPS-12N, MODEL CPS-16F).....	144
6.1.2 MODEL JANCD-FCIOOB ". ". . ". o... o" C. COB	146
6.1.3 MODEL JANCD-FC190-1	148
6.1.4 MODEL JANCD-FC200	150
6.1.5 MODEL JANCD-FC210-1	152
6.1.6 MODEL JANCD-FC222/FC224	154
6.1.7 MODEL JANCD-FC230B	156
6.1.8 MODEL JANCD-FC240	158
6.1.9 MODEL JANCD-FC300B-3	160
6.1.10 MODEL JANCD-FC250(INTEXB BOARD: STANDARD SPECIFICATIONS) ..	162
6.1.11 MODEL JANCD-FC251(INTEXB BOARD: HIGH-SPEED SPECIFICATIONS) ..	164
6.1.12 MODEL JANCD-FC250-1, 2 (MOTION BOARD)	166
6.1.13 MODEL JANCD-FC310-1	168
6.1.14 MODEL JANCD-FC400	170
6.1.15 MODEL JANCD-FC410	172
6.1.16 MODEL JANCD-FC420	174
6.1.17 MODEL JANCD-FC430	176
6.1.18 MODEL JANCD-FC440	178
6.1.19 BACK BOARD (MODELS JANCD-FC001, -FC002, -FC050, -FC052).....	180
6.1.20 11-SLOT BACK BOARD (MODEL JANCD-FC006).....	182
6.2 MACHINE CONTROL STATION	184
6.2.1 9" AMGC CONTROL PANEL (MODEL JZNC-IOP01).....	184
6.2.1.1 MODEL JANCD-FC900B	184
6.2.1.2 MODEL JANCD-FC901	187
6.2.1.3 MODEL JANCD-FC903-1	188
6.2.1.4 9" MONOCHROME GRAPHIC CRT UNIT (MDT948B-3B).....	189
6.2.1.5 KEYBOARD (MODEL DF8203788)	190
6.2.2 14" ACGC CONTROL PANEL (MODEL JZNC-IOP11).....	191
6.2.2 .1 MODEL JANCD-FC950-100" O	191
6.2.2.2 MODEL JANCD-FC951	193
6.2.2.3 14" COLOR GRAPHIC CRT UNIT (MODEL TX1424AD) .0	194
6.2.2.4 KEYBOARD (MODEL DF8203921)	195
7. SETTING AN DADJUSTM EN TOF EACH MODULE	197
8. OPERATIONS OF FIXED FILES	203
8.1 TYPES OF FIXED FILES	204
8.2 DISPLAY AND WRITING OF FIXED FILES	205

INDEX

Subject	Chapter	Par	Page
A ACSERVOMOTOR	2	2.4	62
ADJUSTMENTS UPON INSTALLATION	5		135
ALARM 1099 (TEMPERATURE ALARM INSIDE THE PANEL)	4	4.2.4	88
ALARM 3001 (CONTROL NOT READY)	4	4.2.9	92
ALARM 3002 (EMERGENCY STOP)	4	4.2.10	93
ALARM INDICATION JOB	4	4.2.1.1	79
ALARMS 0010 AND 0011 (PARITY ERROR)	4	4.2.2	82
ALARMS 0016, 0017, 0018, 9016, 9017, AND 9018 (RS-232C ERROR) ..	4	4.2.3	83
ALARMS 2061 TO 2068 (ZERO POINT RETURN AREA ERROR)	4	4.2.5	89
ALARMS 2071 TO 2078, 2081 TO 2088 (REFERENCE POINT RETURN AREA ERROR)	4	4.2.6	90
ALARMS 2101 T02108(P-SET ERROR)	4	4.2.7	91
ALARMS 3000 (SERVO UNREADY)	4	4.2.8	92
ALARMS 3041 TO 3048 (EXCESSIVE POSITION LAG)	4	4.2.11	94
ALARMS 3051 TO 3054 (EXCESSIVE POSITION LAG)	4	4.2.12	95
ALARMS 3061 TO 3068 (MOTOR OVERLOAD)	4	4.2.13	96
ALARMS 3081 TO 3088 (PG DISCONNECTION ERROR)	4	4.2.14	96
ALARMS 3091 TO 3094 (SPINDLE PG DISCONNECTION ERROR) ..	4	4.2.15	97
ALARMS 3121 T03128 (EXCESSIVE SPEED)	4	4.2.16	97
ALARMS 3141 TO 3148 (PREVENTION OF UNCONTROLLED RUNNING)	4	4.2.17	98
ALARMS 3161 TO 3168 (ABSOLUTE ERRORS)	4	4.2.18	98
ALARMS 3181 T03188 (POSITION ERRORS)	4	4.2.19	99
ALARMS 3201 TO 3208 (SERVO DRIVE UNIT COMMUNICATION ERRORS)	4	4.2.20	99
ALARMS 3301 TO 3305 (OVERCURRENT)	4	4.2.21	100
ALARMS 3311 TO 3315 (MCCB TRIP)	4	4.2.22	100
ALARMS 3321 TO 3325 (REGENERATIVE ERROR)	4	4.2.23	100
ALARMS 3331 TO 3335 (OVERVOLTAGE)	4	4.2.24	101
ALARMS 3341 TO 3345 (UNDERVOLTAGE)	4	4.2.25	101
ALARMS 3351 TO 3355 (HEAT SINK OVERHEAT)	4	4.2.26	101
ALARMS 3361 TO 3365 (WIRE BREAK IN CURRENT INSTRUCTION CABLE)	4	4.2.27	102
ALARMS 3371 TO 3375 (MISSING PHASE)	4	4.2.28	102
B BACK BOARD (MODELS JANCD-FC001, -FC002, -FC050, -FC052)	6	6.1.19	180
BATTERY	2	2.5	63
c CHECK AT POWER SUPPLY VOLTAGE	4	4.4.1	128
CHECK DC POWER SUPPLY VOLTAGE	4	4.4.3	129
COMPONENTS	1	1.2	11
COMPONENTS AND INTERCONNECTIONS	1	1.1	2
CONTROL PANEL	2	2.3	60
CRT SCREEN DOES NOT DISPLAY	4	4.3.3	113
CYCLE START FAILURE	4	4.3.8	120
D DETAILS OF FUNCTION	4	4.3.2.2	105
DISPLAY AND WRITING OF FIXED FILES	8	8.2	205
DISPLAY METHOD	4	4.2.1	77
DISPLAYING INPUT/OUTPUT SIGNALS	4	4.5.2	131
E EDIT DOES NOT FUNCTION	4	4.3.12	124
II-SLOT BACK BOARD (MODEL JANCD-FC006)	6	6.1.20	182
F FIN WAIT OCCURS BY SPINDLE RELATED INSTRUCTION	4	4.3.13	125
14" ACGC CONTROL PANEL (MODEL JZNC-IOP11)	6	6.2.2	191
14" COLOR GRAPHIC CRT UNIT (MODEL TX1424AD)	6	6.2.2.3	194
H HANDLE MODE OPERATION FAULTY	4	4.3.4	113
I INDICATION OF LAMP OF POWER SUPPLY UNIT	4	4.4.2	129
K KEYBOARD (MODEL DF8203788)	6	6.2.1.5	190
KEYBOARD (MODEL DF8203921)	6	6.2.2.4	195

INDEX (Cent'd)

Subject	Chapter	Par.	Page
M MACHINE CONTROL STATION	6	6.2	184
MAINTENANCE INSTRUMENTS	3		67
MANUAL JOG MODE OPERATION FAULTY	4	4.3.5	115
MANUAL RAPID MODE OPERATION FAULTY	4	4.3.6	117
MANUAL ZERO RETURN OPERATION FAULTY	4	4.3.7	119
MODEL JANCD-FC100C	6	6.1.2	146
MODEL JANCD-FC190-1	4	6	148
MODEL JANCD-FC200	6	6.1.4	150
MODEL JANCD-FC210-1	6	6.1.5	152
MODEL JANCD-FC222/FC224	6	6.1.6	154
MODEL JANCD-FC230B	6	6.1.7	156
MODEL JANCD-FC242	6	6.1.8	158
MODEL JANCD-FC250 (INTEXB BOARD : STANDARD SPECIFICATIONS)	6	6.1.10	162
MODEL JANCD-FC250-1, 2 (MOTION BOARD)	6	6.1.12	166
MODEL JANCD-FC251 (INTEXB BOARD : HIGH SPEED SPECIFICATIONS)	6	6.1.11	164
MODEL JANCD-FC300B-3	6	6.1.9	160
MODEL JANCD-FC310-1	6	6.1.13	168
MODEL JANCD-FC400	6	6.1.14	170
MODEL JANCD-FC410	6	6.1.15	172
MODEL JANCD-FC420	6	6.1.16	174
MODEL JANCD-FC430	6	6.1.17	176
MODEL JANCD-FC440	6	6.1.18	178
MODEL JANCD-FC900B	6	6.2.1.1	184
MODEL JANCD-FC901	6	6.2.1.2	187
MODEL JANCD-FC903-1	6	6.2.1.3	188
MODEL JANCD-FC950-1	6	6.2.2.1	191
MODEL JANCD-FC951	6	6.2.2.2	193
MODULE/UNIT REPLACEMENT PROCEDURE	6		143
N NCRACK	6	6.1	144
9" AMGC CONTROL PANEL (MODEL JZNC-IOP01)	6	6.2.1	184
9" CRT SCREEN IS DARK	4	4.3.11	123
9" MONOCHROME GRAPHIC CRT UNIT (MDT948-3B)	6	6.2.1.4	189
o OPERATION IS NOT AVAILABLE WITH GO1, G02, OR G03	4	4.3.9	121
OPERATIONS OF FIXED FILES	8		203
OUTLINE	1		1
OUTLINE OF DISPLAY	4	4.5.1	130
P POWER CANNOT BE SUPPLIED	4	4.3.1	103
POWER SUPPLY UNIT (MODEL CPS-12N, MODEL CPS-16F)	6	6.1.1	144
POWER SUPPLY VOLTAGE CHECK	4	4.4	128
R RECOGNITION OF NC SYSTEM	4	4.1.2	72
RECOGNITION OF TROUBLE STATUS	4	4.1.1	71
ROUTINE INSPECTION	2	2.1	58
ROUTINE INSPECTION SCHEDULE	2		57
s SELF-DIAGNOSIS FUNCTIONS	4	4.3.2.1	104
SETTING AND ADJUSTMENT OF EACH MODULE	7		197
SKIP FUNCTION (G31) OPERATION FAILURE	4	4.3.14	126
SOLUTION TO ERRORS DETECTED IN SELF-DIAGNOSIS	4	4.3.2	104
SPINDLE DOES NOT ROTATE	4	4.3.10	122
STATUS DISPLAY BY SELF-DIAGNOSIS FUNCTION (DGN)	4	4.5	130
T TAPE MODE DOES NOT FUNCTION	4	4.3.15	127
TAPE READER MAINTENANCE	2	2.2	59
TROUBLE IDENTIFICATION	4	4.1	71
TROUBLESHOOTING	4		69
TROUBLESHOOTING BY ALARM CODES	4	4.2	77
TROUBLESHOOTING WITHOUT ALARM CODES	4	4.3	103
TYPES OF FIXED FILES	8	8.1	204

1. OUTLINE

The YASNAC i80 provides you with an internal self-diagnosis function. System maintenance can easily be accomplished with DGN and other main functions as listed below;

(1) Microprocessor always monitors the machine operations internally and can display the status with function keys.

If any failure occurs, NC immediately stops with the blinking of alarm displays. Also the same procedure can be executed on machine sequence for the application of built-in type programmable controller.

(2) ON/OFF SIGNAL of Input to NC/Output from NC can be displayed with DGN.

(3) Setting value of various parameters such as accel/decel time constant and rapid speed can be checked on the CRT,

CONTENTS

1. OUTLINE	1
1.1 COMPONENTS AND INTERCONNECTIONS	2
1.2 COMPONENTS	11

1.1 COMPONENTS AND INTERCONNECTIONS

(1) Component Arrangement

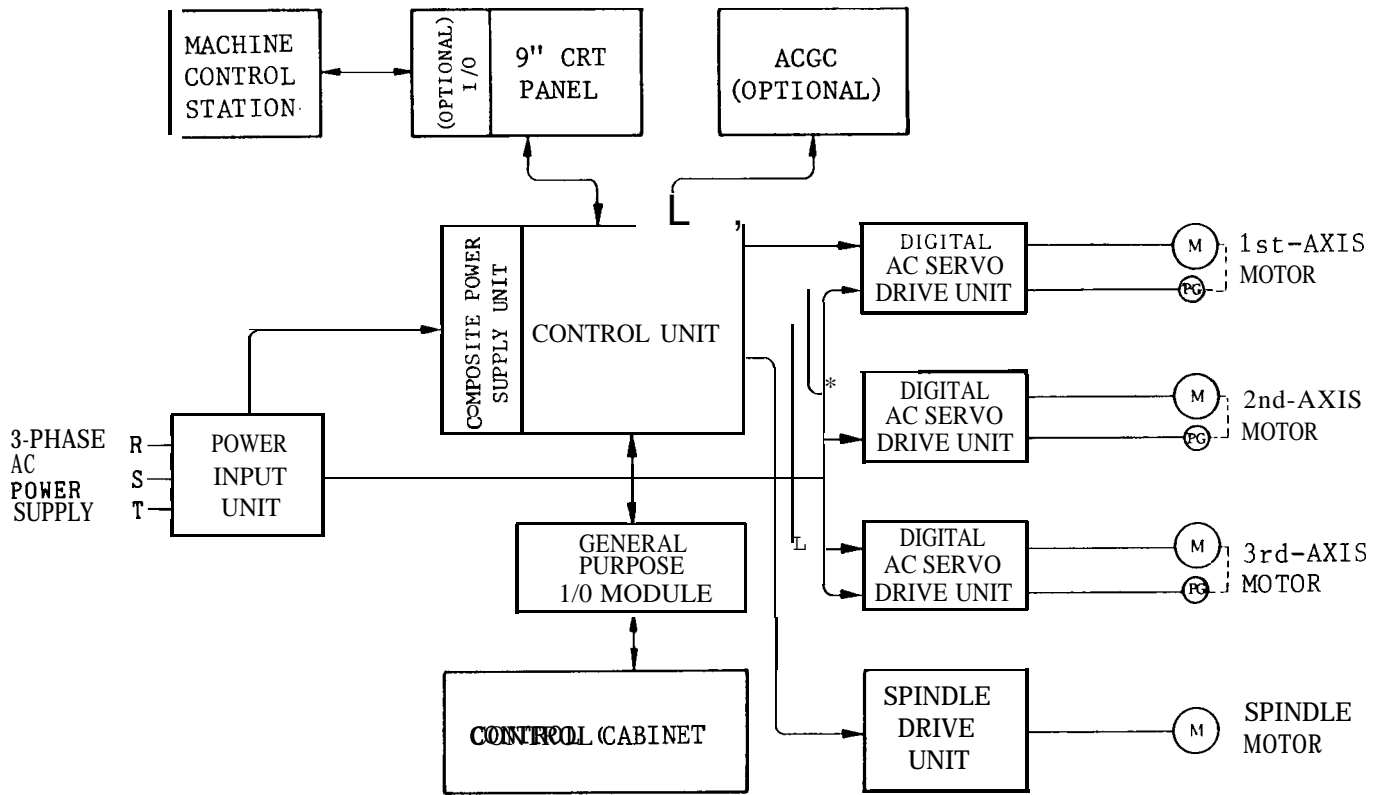

Fig. 1.1 Component Arrangement of YASNACi

(2) Interconnection Diagram

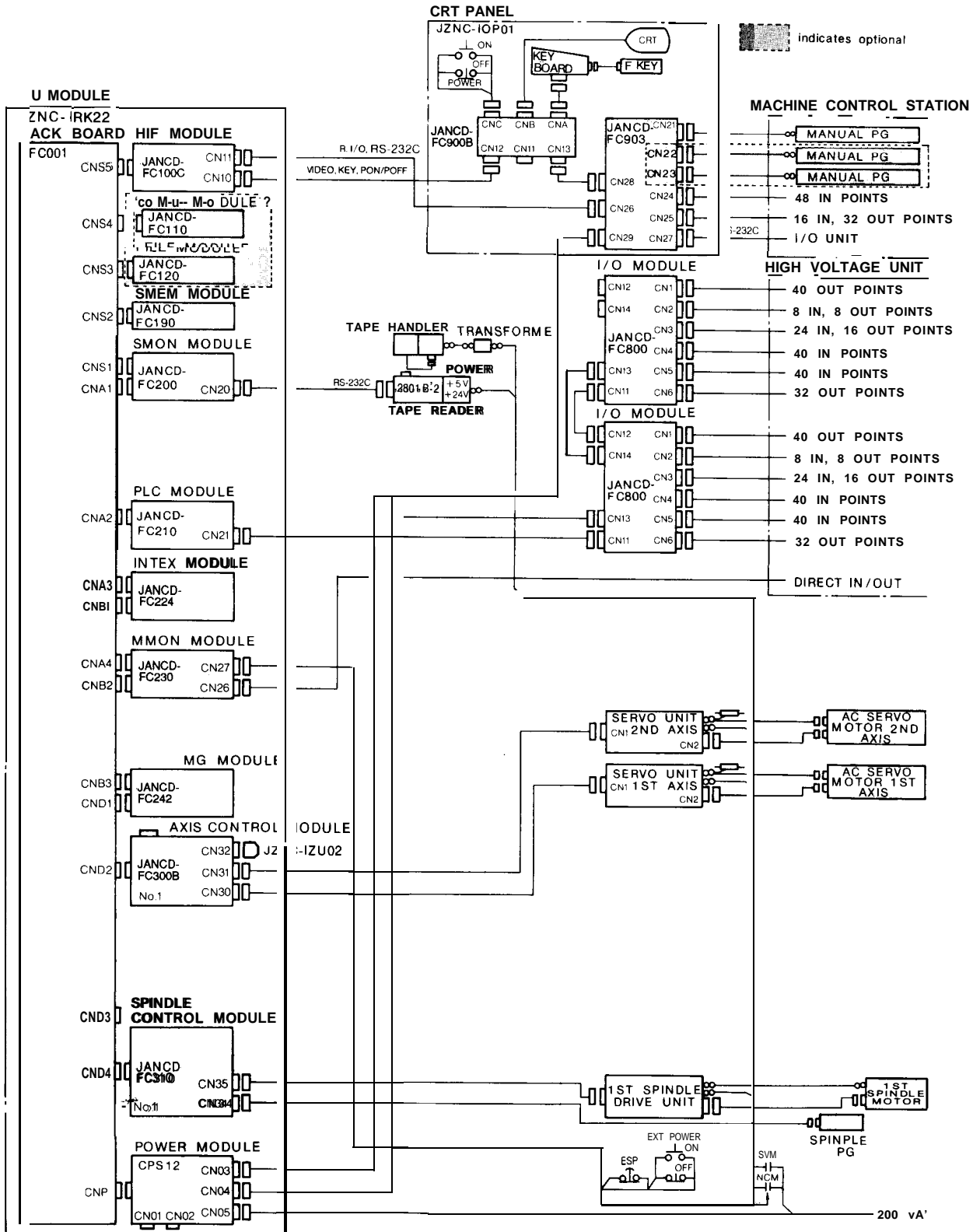

Fig. 1.2 Interconnection Diagram (YASNAC-i80L for Lathe)

1.1 COMPONENTS AND INTERCONNECTIONS (Cent'd)

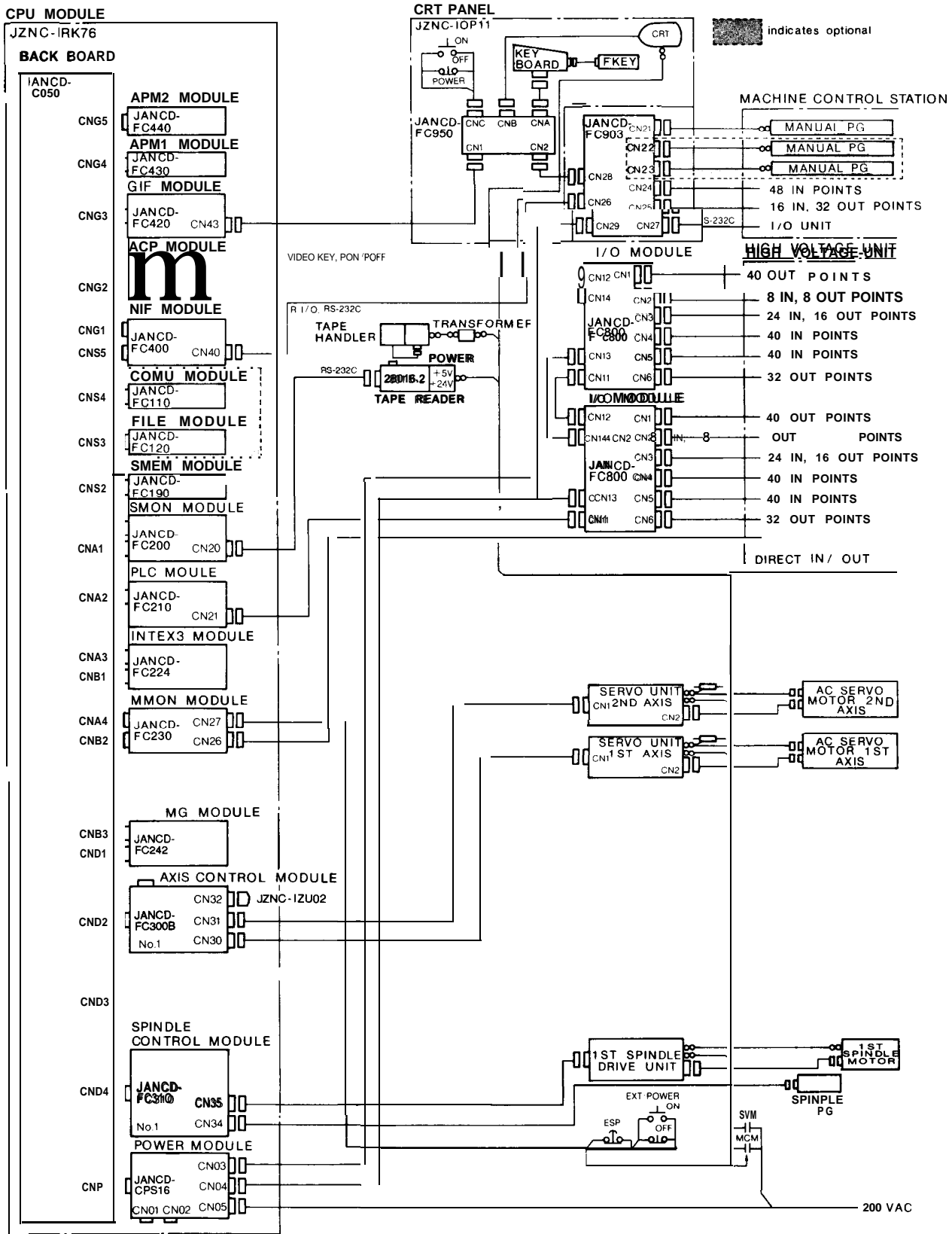

Fig. 1.3 Interconnection Diagram [Y AS NAC-i80L for Lathe with ACGC]

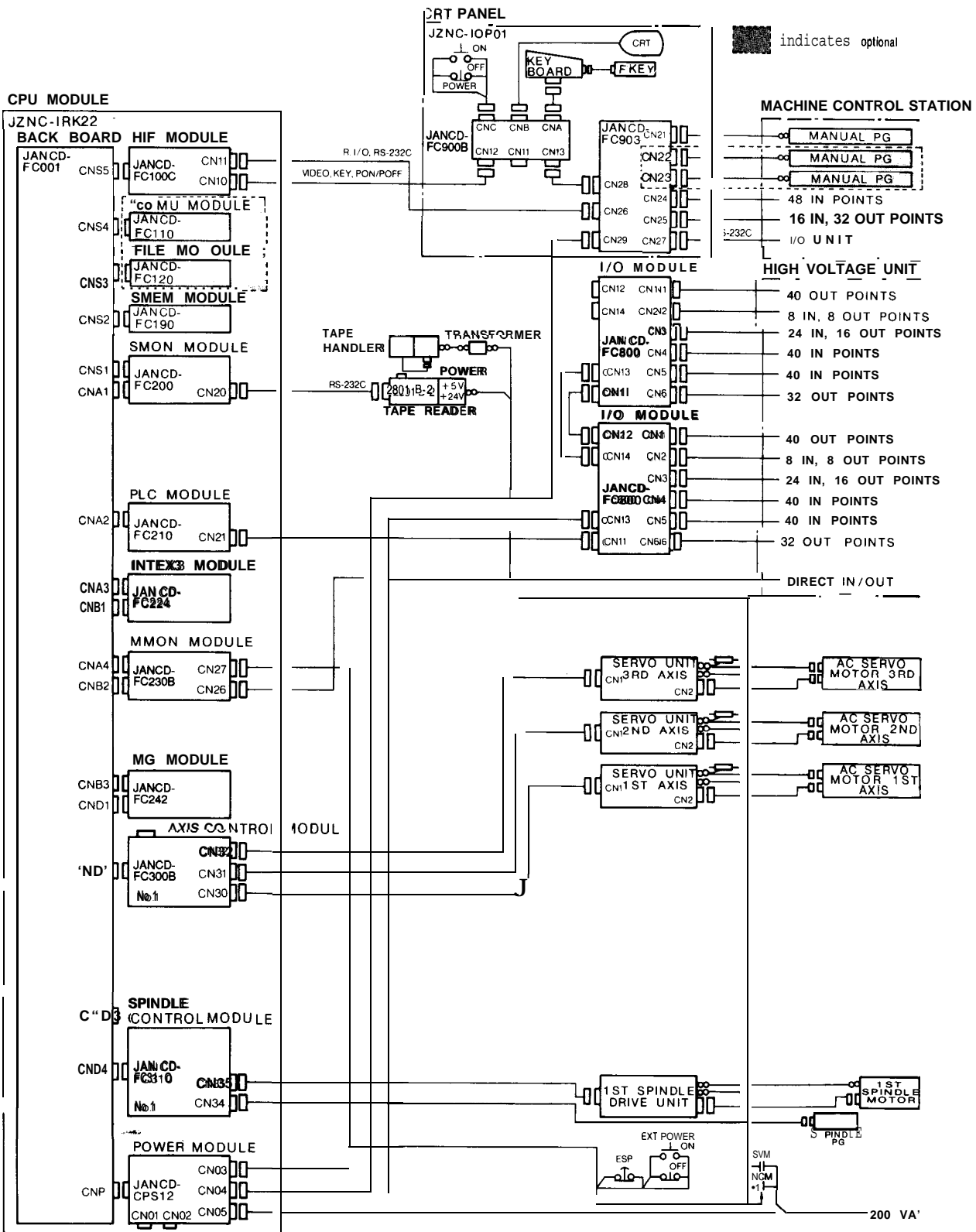

Fig. 1.4 Interconnection Diagram [Y AS NAC-i80M for Machining Center]

1.1 COMPONENTS AND INTERCONNECTIONS (Cent'd)

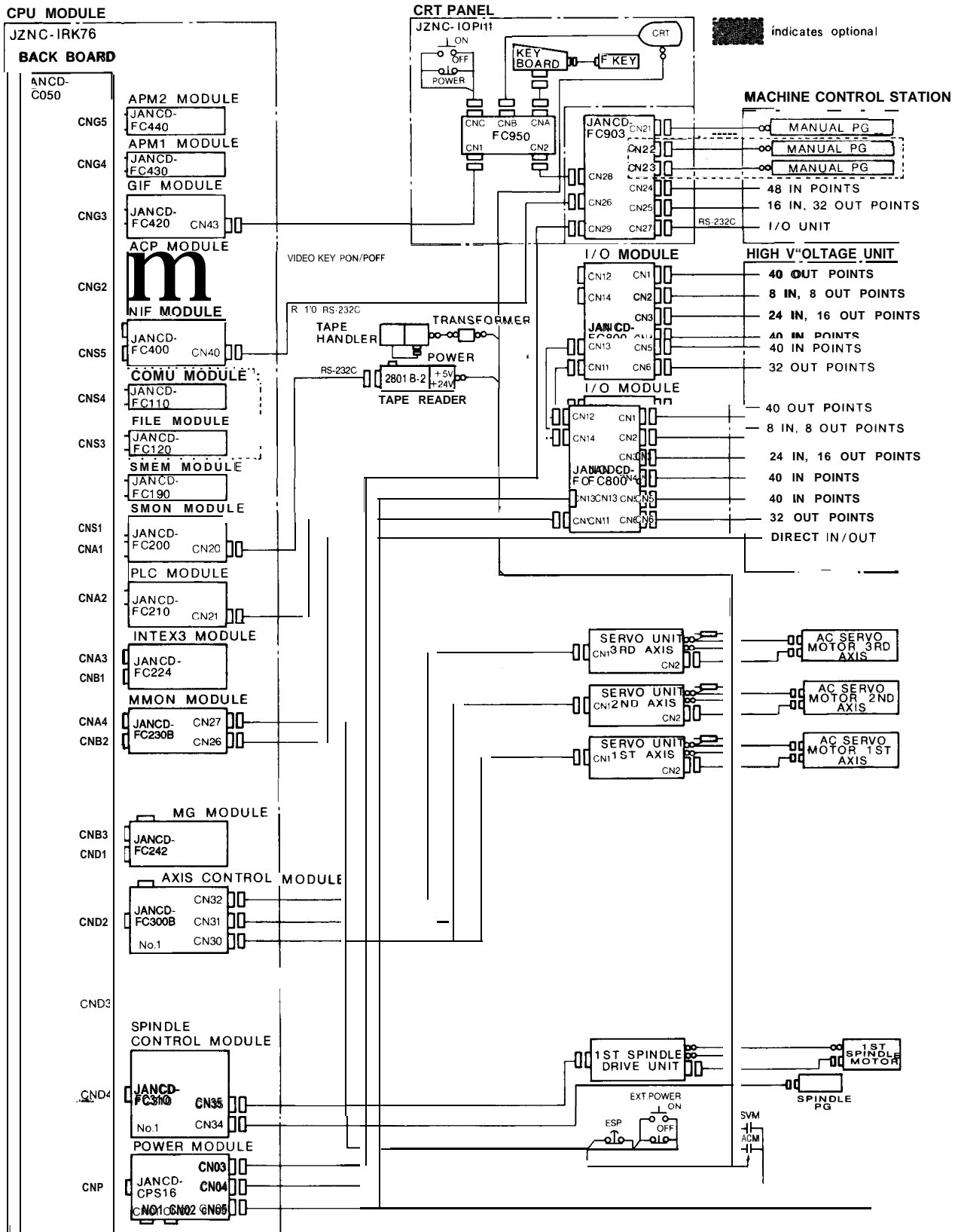

Fig. 1.5 Interconnection Diagram [Y AS NAC-i80M for Machining Center with ACGC]

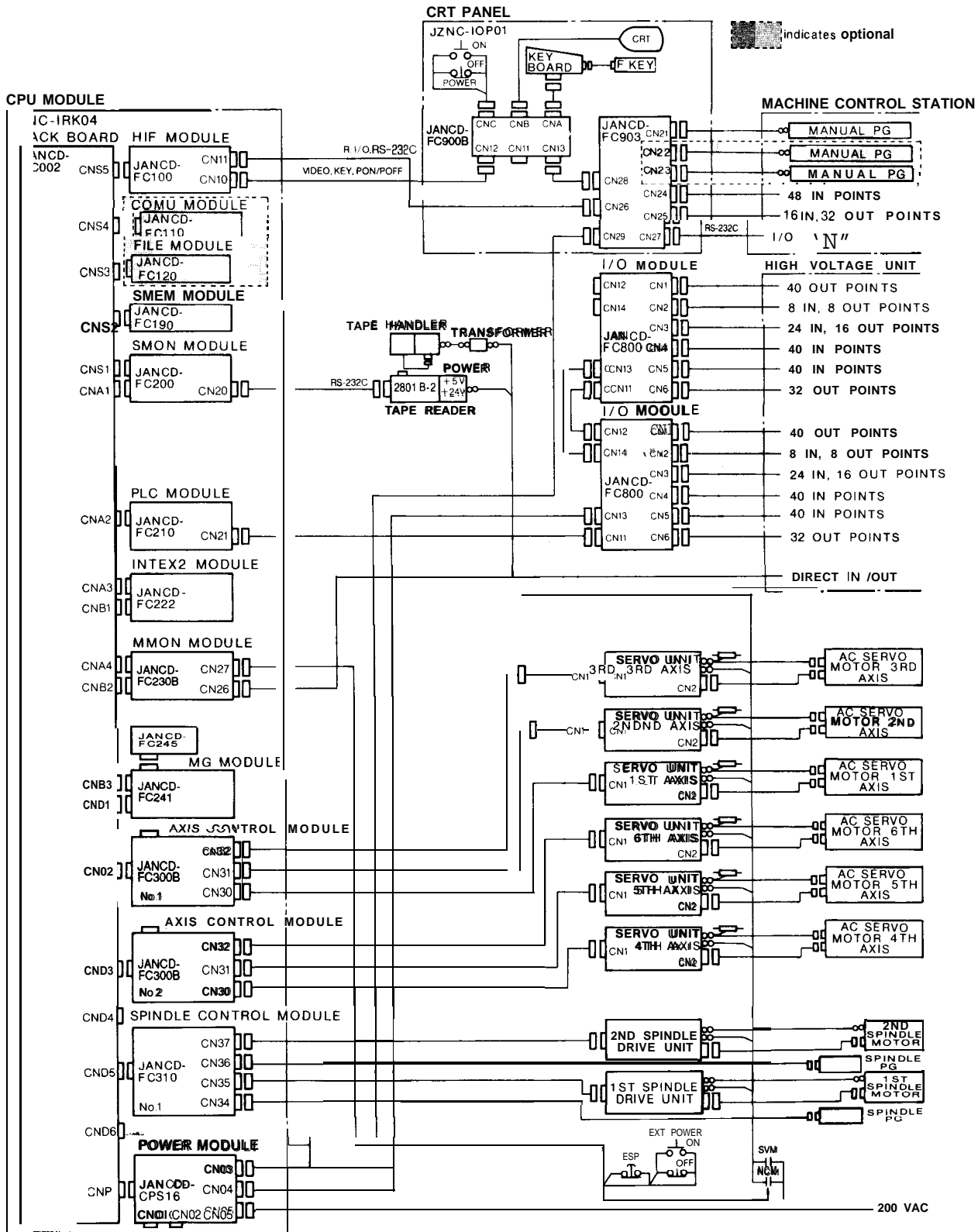

Fig. 1.6 Interconnection Diagram [Y AS NAC-i80L for Multi-Axis Lathe)

1.1 COMPONENTS AND INTERCONNECTIONS (Cent'd)

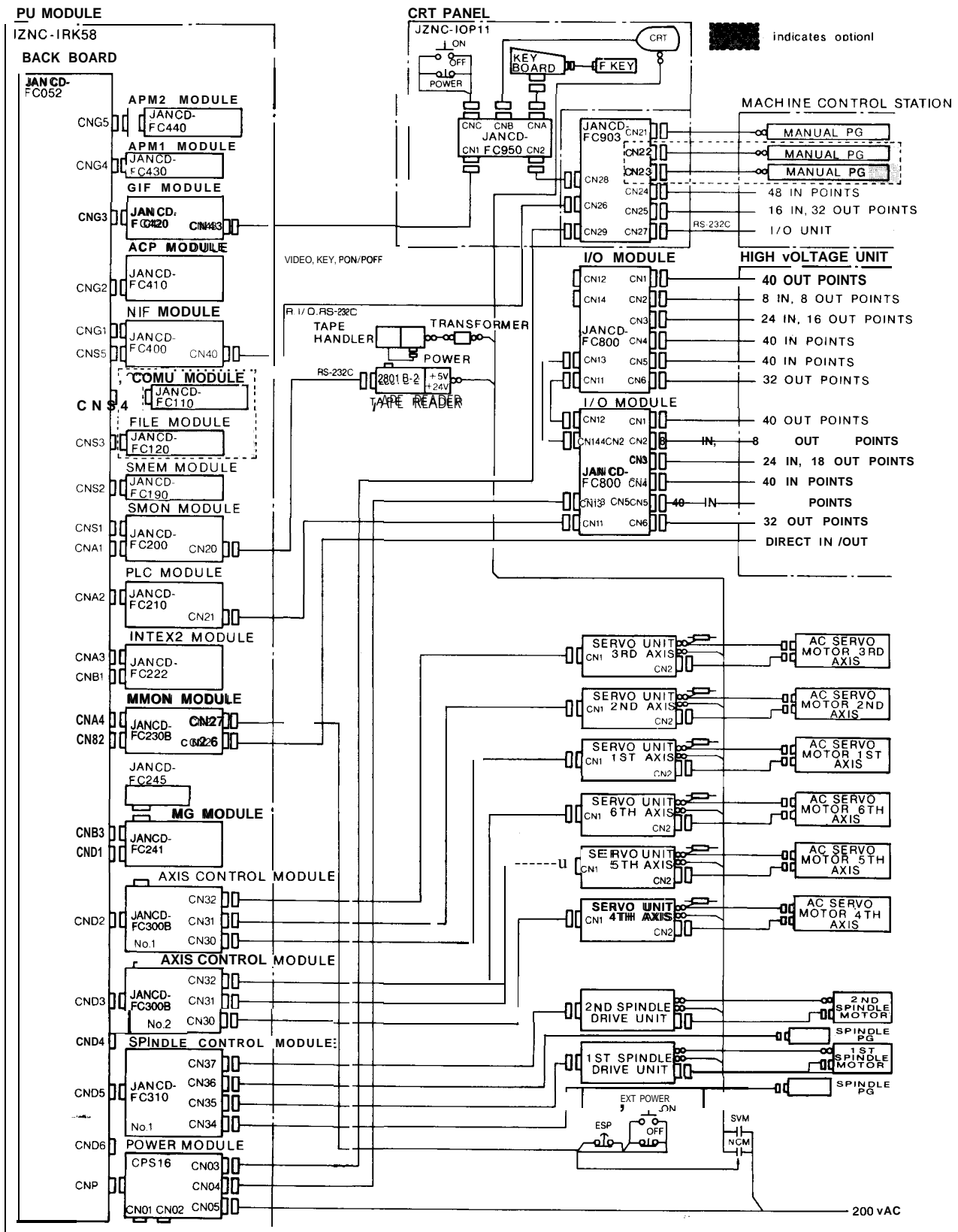

Fig. 1.7 Interconnection Diagram [Y AS NAC-80L for Multi-Axis Lathe with ACGC]

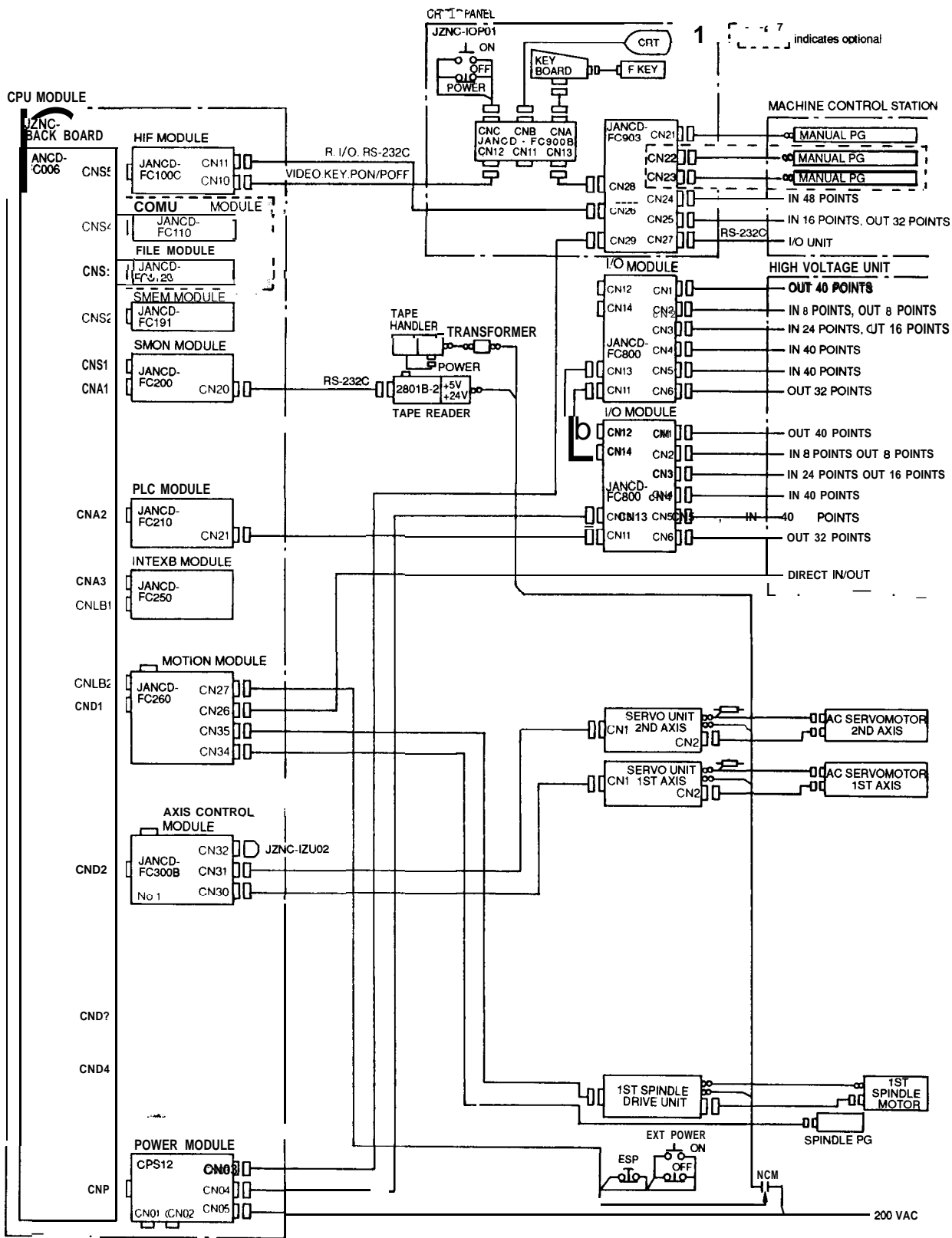

Fig. 1.8 Interconnection Diagram [Y AS NAC-i80LB for Lathe]

1.1 COMPONENTS AND INTERCONNECTIONS (Cent'd)

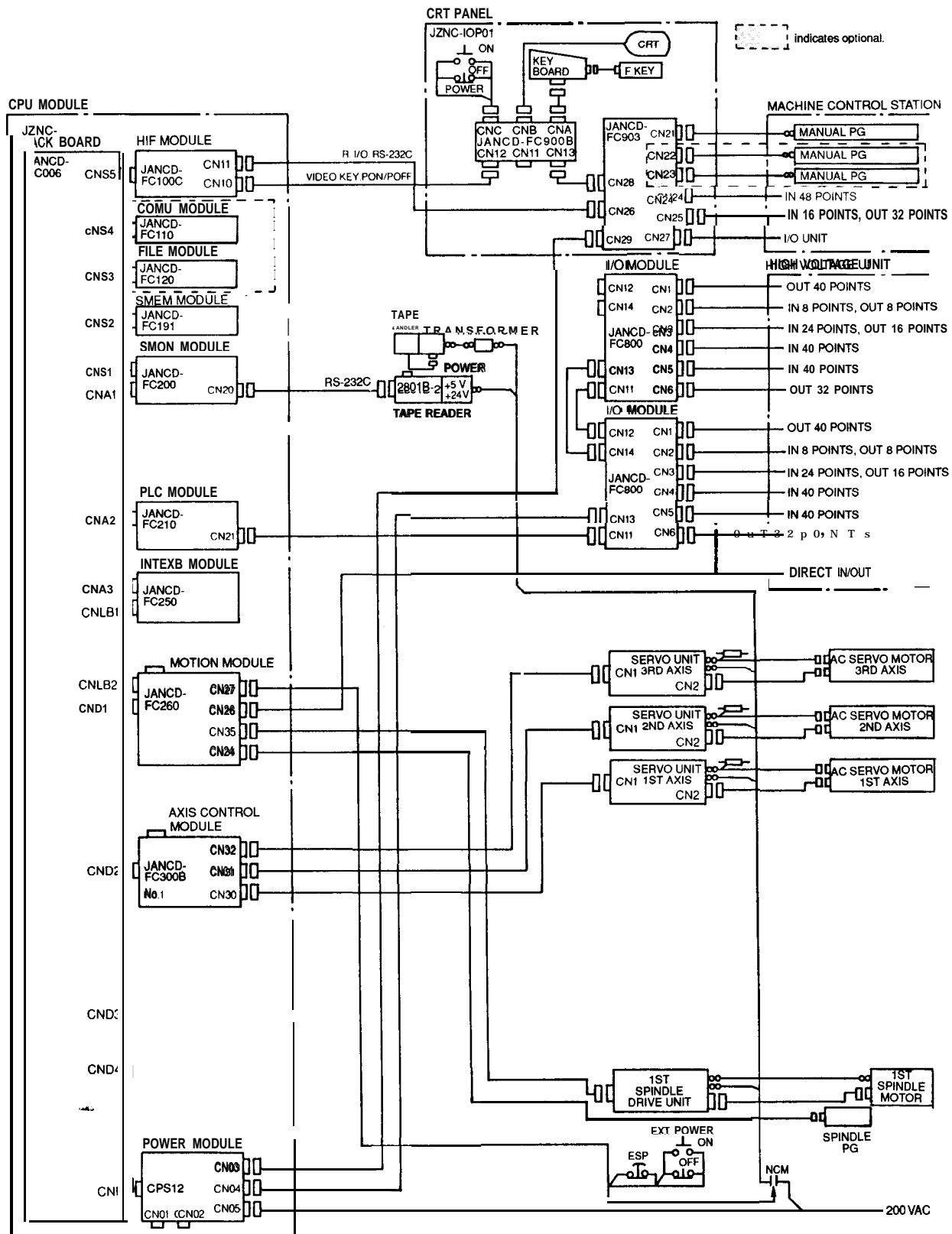

Fig. 1.9 Interconnection Diagram [Y AS NAC-i80MB for Machining Center]

1.2 COMPONENTS

(1) NC Major Components

Table 1.1 NC Major Components

Component Name	Model	Supply Code	Remarks
9" AMGC NC Rack 1	JZNC-IRK22		Feed control: 3 axes; spindle control: 1 axis; standard rack
9" AMGC NC Rack 2	JZNC-IRK04		Feed control: 6 axes; spindle control: 2 axes; rack for multiaxis
9" AMGC NC Rack3	JZNC-IRK31	—	Feed control: 3 axes; spindle control: 1 axis; standard rack
9" AMGC NC Rack 4	JZNC-IRK31	—	Feed control: 5 axes; spindle control: 2 axes; rack for multiaxis
14" ACGC NC Rack 1	JZNC-IRK76		Feed control: 3 axes; spindle control: 1 axis; rack for ACGC
14" ACGC NC Rack 2	JZNC-IRK58		Feed control: 6 axes; spindle control: 2 axes; rack for ACGC multiaxis
9" AMGC Control Panel	JZNC-IOPOIE	DUN20280	9" black-and-white CRT. IHPG panel with I/O
14" ACGC Control Panel	JZNC-IOP11E	DUN20310	14" color CRT, without panel I/O
Remote I/O Module	JANCD-FC800	DTN8150	112-point input, 96-point source output
Panel I/O Unit	JZNC-IAU02-1	DUN20820	Separated-type panel I/O unit, 1HPG
	JZNC-IAU02-2	DUN20830	Separated-type panel I/O unit, 2HPG
	JZNC-IAU02-3	DUN20840	Separated-type panel I/O unit, 3HPG
Tape Reader Unit	JZNC-IAU51	—	200VAC input RS-232C tape reader unit

▪ JZNC-IRK22	Module	—	Go to (2).
▪ JZNC-IRK04	Module	—	Go to (3).
▪ JZNC-IRK31	Module	—	Go to (4).
▪ JZNC-IRK41	Module	—	Go to (5).
▪ JZNC-IRK76	Module	—	Go to (6).
▪ JZNC-IRK58	Module	—	Go to (7).
▪ JZNC-IOP01 E	Module	—	Go to (8).
▪ JZNC-IOP11E	Module	—	Go to (9).
▪ JZNC-IAU51	Module	—	Go to (10).
▪ Option Modules		—	Go to (11).
▪ YASNAC i80 digital AC servo drive unit		—	Go to (12).
▪ Spindle drive unit		—	Go to (13).
▪ Maintenance unit		—	Go to (14).

1.2 COMPONENTS (Cent'd)

.9" AMGC Standard Rack (Model JZNC-IRK22)

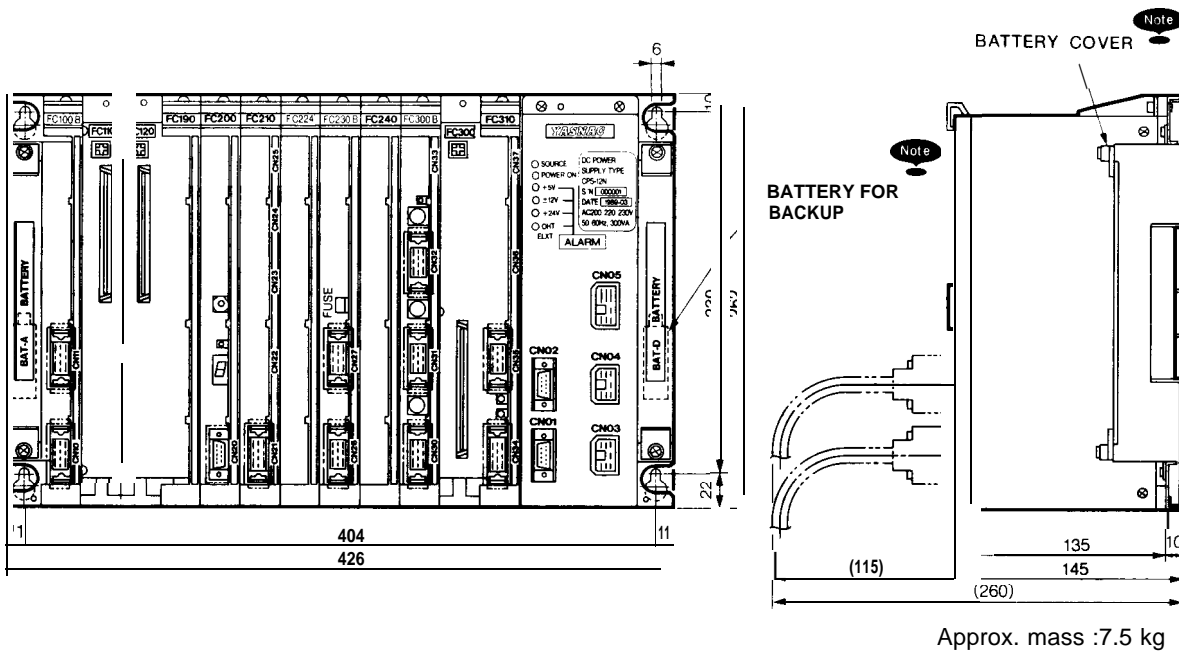

Note When replacing the battery for backup, remove the battery cover.
(one at each side)

.9" AMGC Multiaxis (Model JZNC-IRK04)

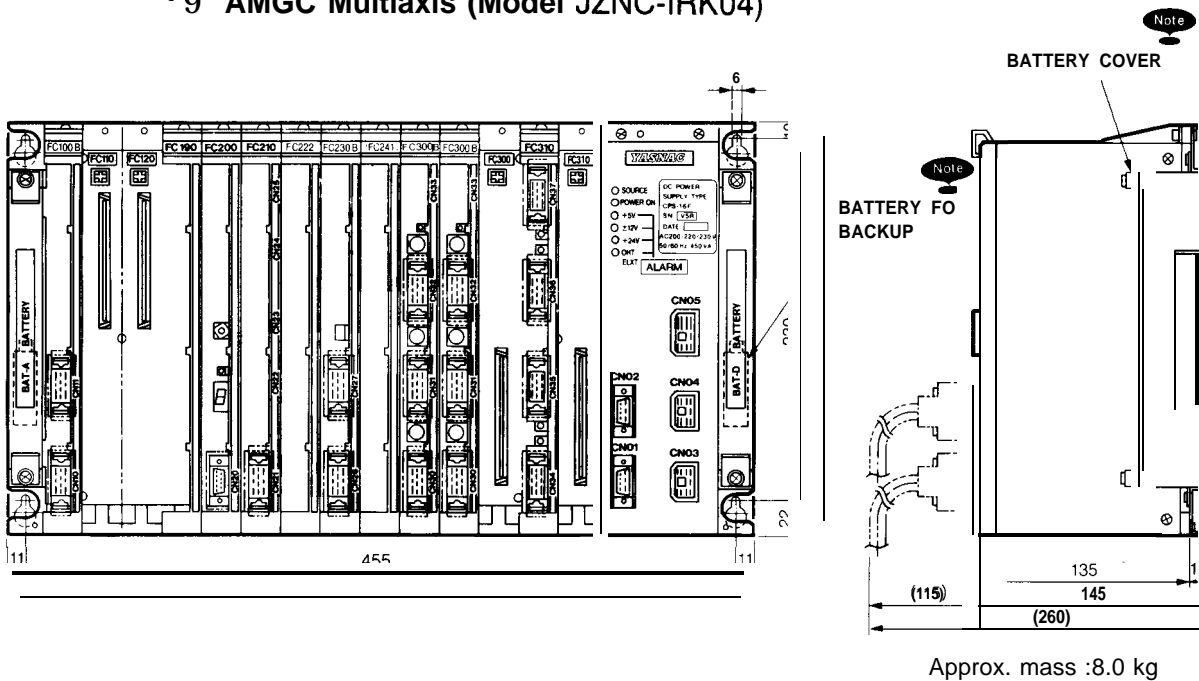

Note When replacing the battery for backup, remove the battery cover.
(one at each side)

.9" AMGC Standard Rack (Model JZNC-IRK31)

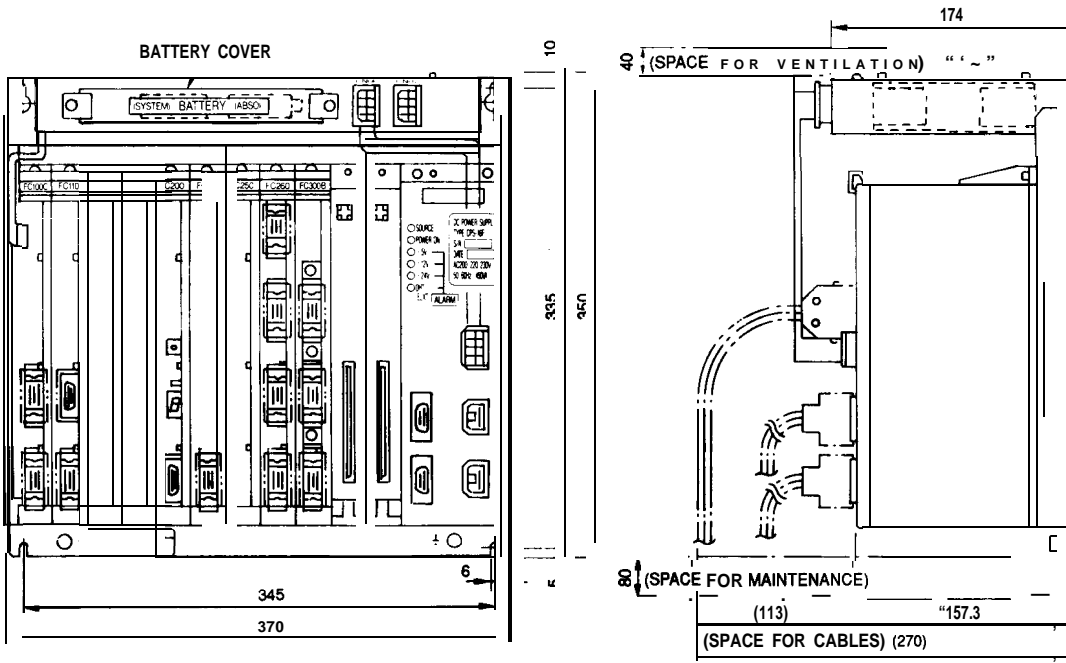

When replacing the battery for backup, remove the battery cover.
(two on the rack)

Approx. mass :12 kg

.9" AMGC Multiaxis (Model JZNC-IRK41)

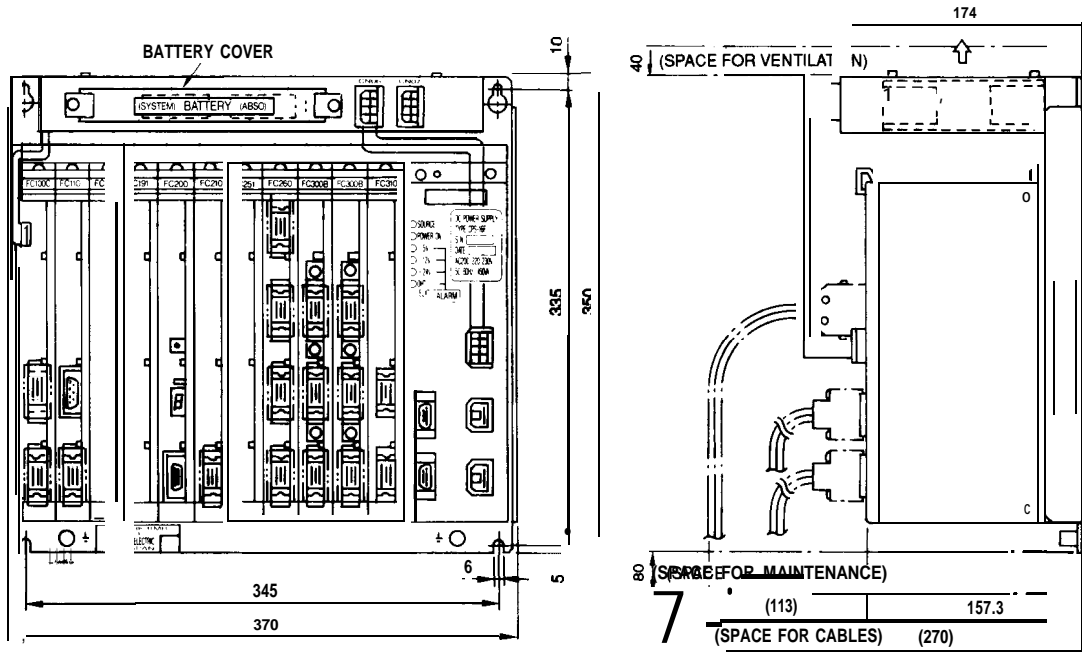

When replacing the battery for backup, remove the battery cover.
(two on the rack)

Approx. mass: 12 kg

1.2 COMPONENTS (Cent'd)

• Rack for 14" ACGC (Model JZNC-IRK76)

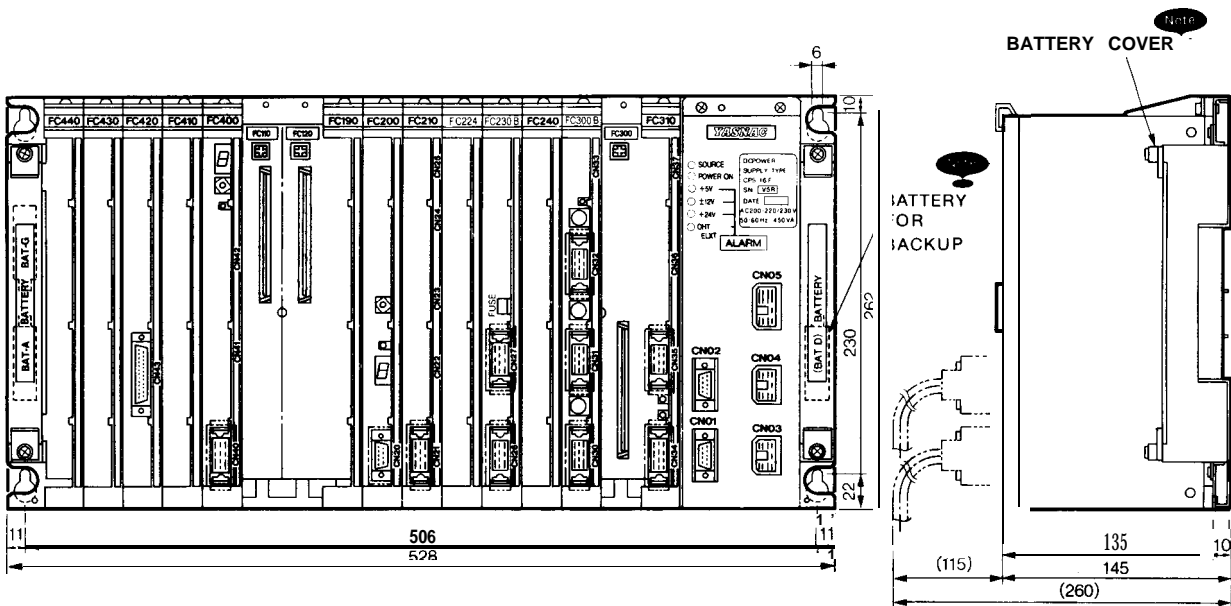

Approx. mass :9.0 k g

Note When replacing the battery for backup, remove the battery cover. (two at the left side and one at the right side)

• Rack for 14" ACGC (Model JZNC-IRK58)

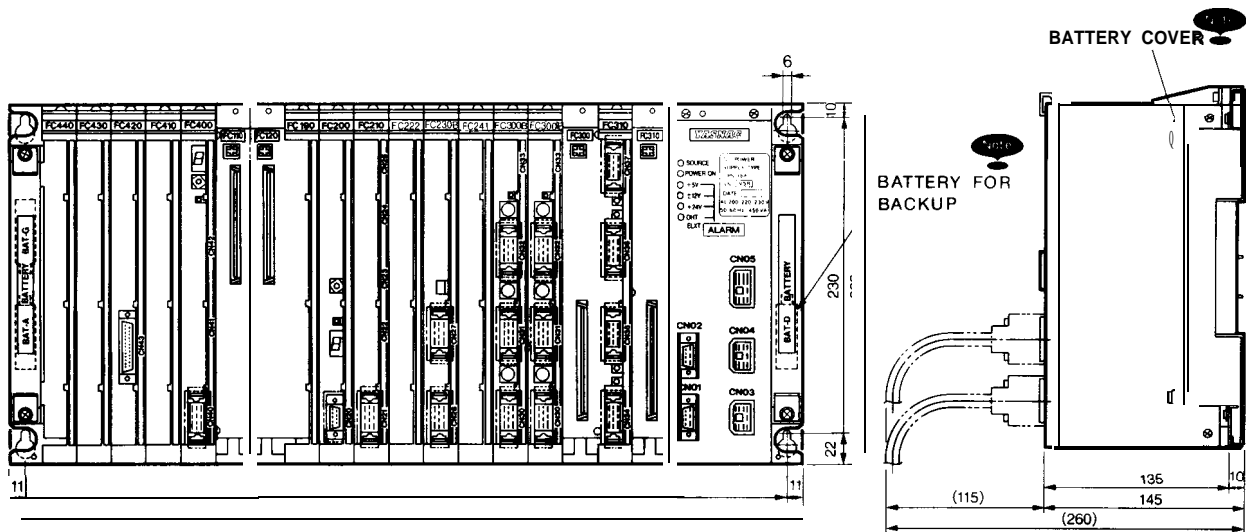

Approx. mass :10 kg

Note When replacing the battery for backup, remove the battery cover. (two at the left side and one at the right side)

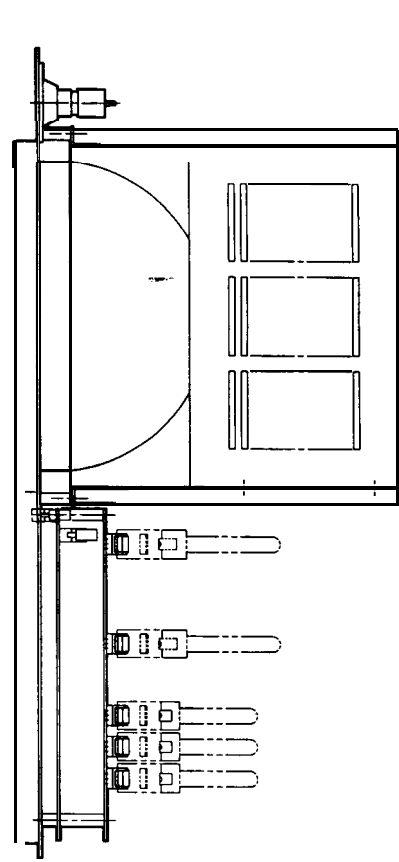

CN12
(FC900B)

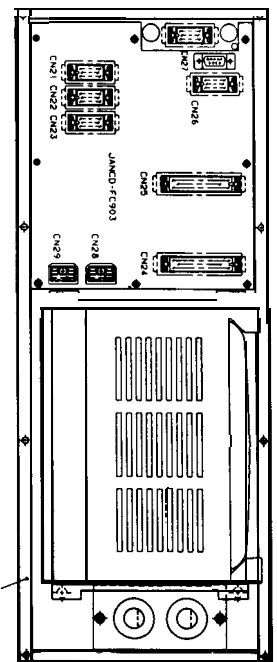

REAR VIEW

PACKING
(ENTIRE CIRCUMFERENCE)

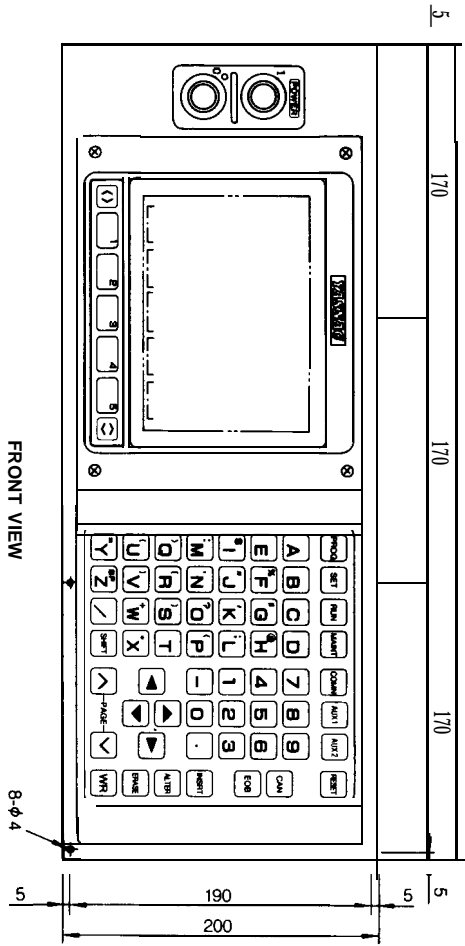

FRONT VIEW

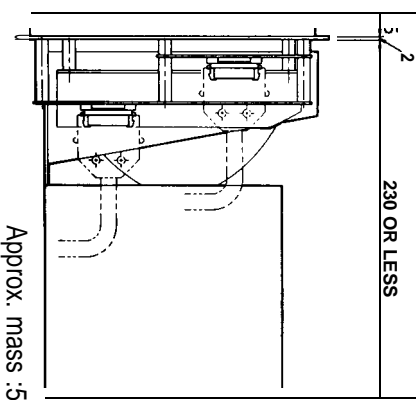

Approx. mass :5.5 kg

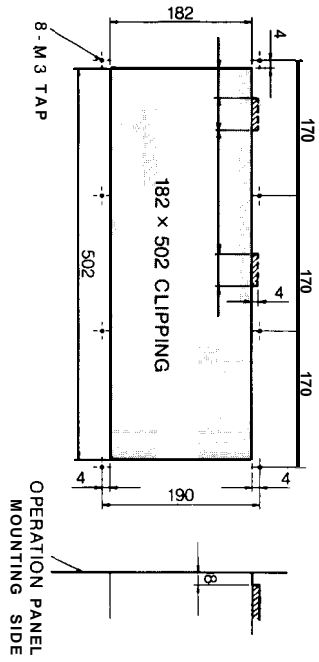

OPERATION PANEL
MOUNTING SIDE

Operation Panel Mounting Hole Processing Diagram

• 9" A GC Control Panel Model JZNC-10P1E

1. Panel surface finish:
Japan Painting Institution Color number No. 1034
Japan Etching Co., Ltd. Satin finish No. 7 equivalent leather-tone painting
2. When the thickness of the operation panel mounting material is 8 mm or more
Notch the slash portion with a depth of 8 mm or more.

Board Name	Connector Number	Board Connector	Cable Connector
JANCD-FC900B	CN12	IR-20RF/D2	MRP-20M01
	CN21	MR-20RF/D2	MRP-20M01
	CN22	MR-20RF/D2	MRP-20M01
	CN23	MR-20RF/D2	MRP-20M01
	CN24	MR-50RMD2	MRP-50F01
	CN25	MR-50RMD2	MRP-50F01
	CN26	MR-20RMD2	MRP-20F01
	CN27	17SE-18090-37 17JE-23090-02(D8B)	
	CN28	17037-1	Already connected
	CN29	172037-1	172026-11

No cable connector is supplied. User must provide an equivalent connector.



1.2 COMPONENTS (Cent'd)

.14" ACGC Operation Panel (Model JZNC-IOP11 E)

CRT 200 VAC Connector model: I-480701-0
 Cable connector: I-480700-0
 Panel painting color: Japan Painting Institution
 Color number No. 1034
 Japan Etching Co., Ltd.
 Satin finish No. 7 equivalent
 leather-tone painting

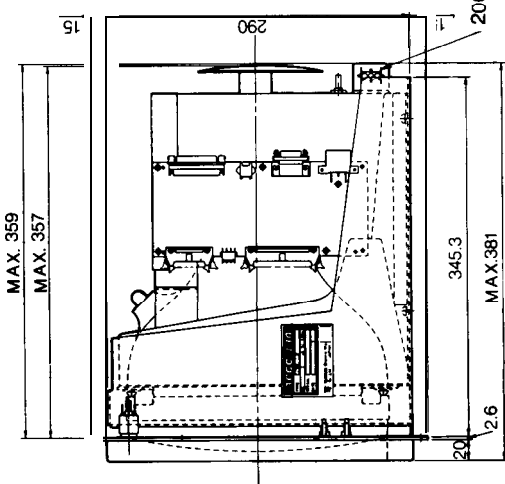
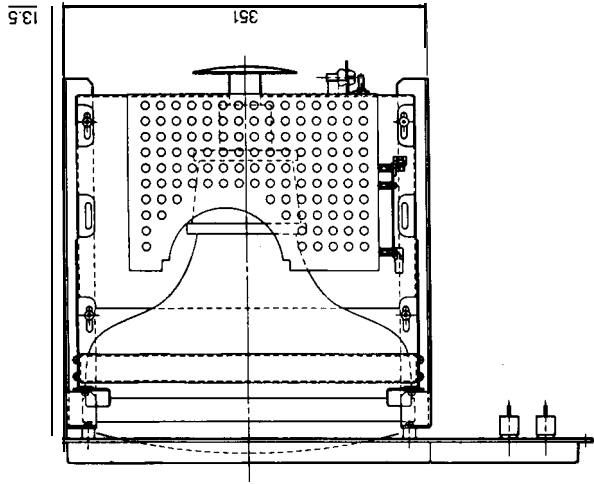

Approx. mass : 20 kg

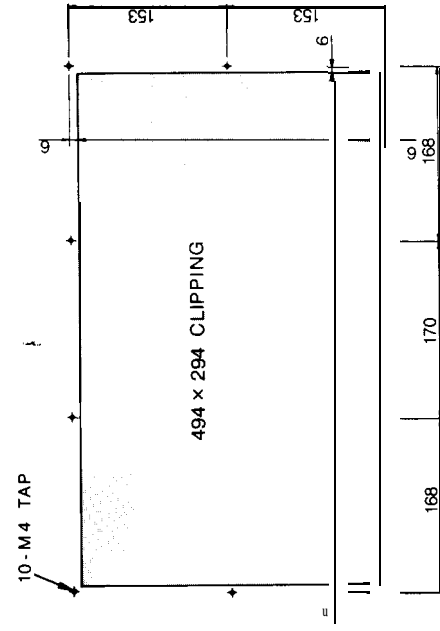

Operation Panel Mounting Hole Processing Diagram

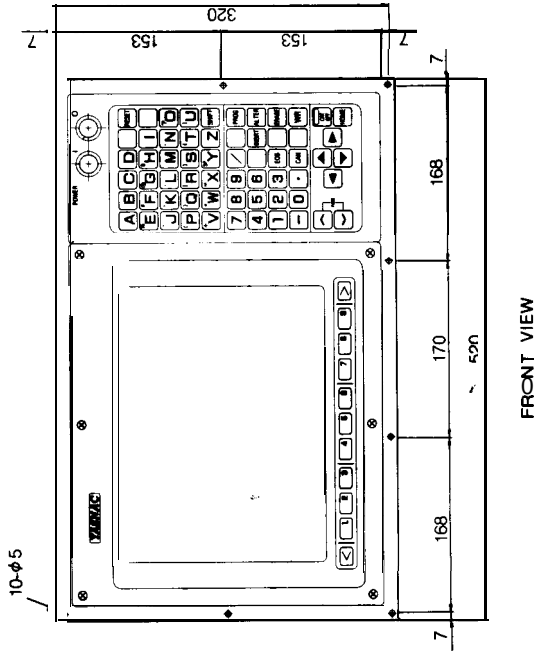

• Remote I/O Module (Model JAN CD-FC800)

1

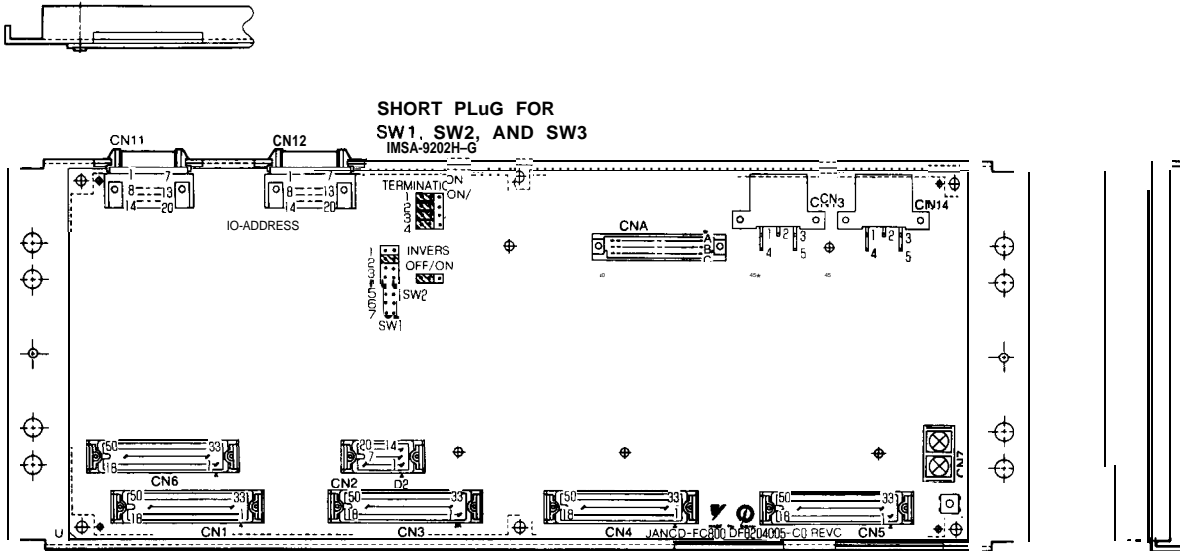

• Panel I/O Unit

Model JZNC-IAU02-1
(HPG1 axis specifications. Without CN22 and CN23)

Model JZNC-IAU02-2
(HPG2 axis specifications. Without CN23)

Model JZNC-IAU02-3
(HPG3 axis specifications)

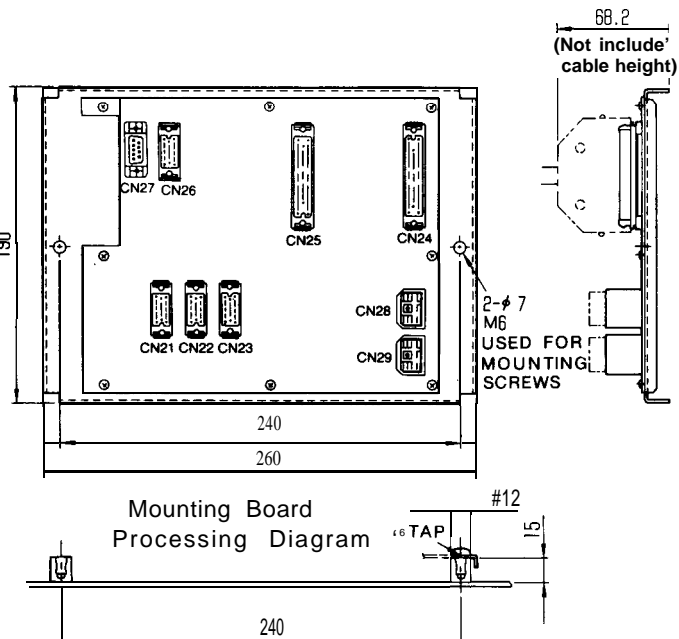

Connector Number	Board Connector	Cable Connector	Remarks
CN21	MR-20RFD2	MRP-20M01	Used for HANDLE PG
CN22	MR-20RFD2	MRP-20M01	Used for HANDLE PG
CN23	MR-20RFD2	MRP-20M01	Used for HANDLE PG
CN24	MR-50RMD2	MRP-50F01	Used for panel I/O
CN25	MR-50RMD2	MRP-50F01	Used for panel I/O
CN26	MR-20RMD2	MRP-20F01	Used for remote I/O
CN27	17JE-13090-37	17JE-23090-02 (D8B)	Used for panel RS-232C
CN28	172037-1	172026-1	Used for power supply
CN29	172037-1	172026-1	Used for power supply

No cable connector is supplied, The machine manufacturer should provide an equivalent connector.

1.2 COMPONENTS (Cent'd)

.Tape Reader Unit (Power Built-in Type) (Model JZNC-IAU51)

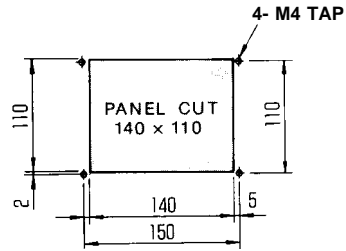
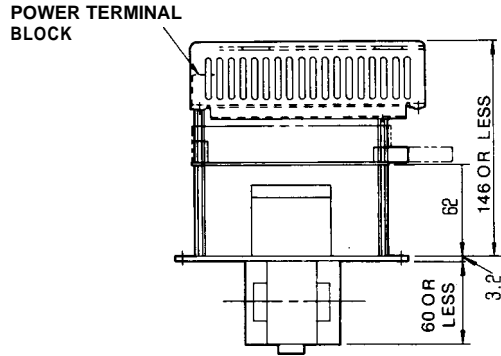

Mounting Hole Processing Diagram

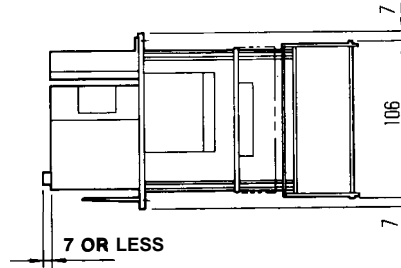
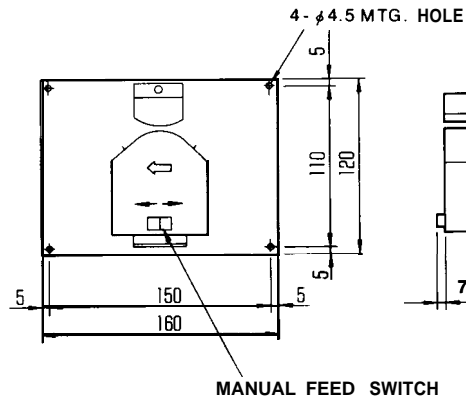

PAINT : SILVER METALLIC PAINT
DIMENSIONS IN mm

(2) JZNC-IRK22 Module

Table 1.2 JZNC-IRK22 Module

Model	Supply Code	Abbreviation	Remarks
CPS-12N	AVR0842	CPS	+5V13A,+24V1.5A,+12V 1.3A, -12V 0.3A
JAN CD-FC001	DTN7010	BB1	AMGC12 slot back board
JAN CD-F C10OC	DTN9770	HIF	9" monochrome CRT/keyboard interface
JAN CD- FC190-1	DTN7020	SMEM	FC200 memory RAM 384kB
JAN CD- FC200	DTN6470	SMON	S y s t e m m a n a g e m e n t
JAN CD-FC210-1	DTN6850	PLC	Sequence controller, without RS-232C
JAN CD-FC224	DTN9450	INTEX3	NC program analysis
JAN CD-FC221	DTN8010	ROMS	ROM board (two boards for model FC224 are used)
JANCD-FC230B	DTN8490	MMON	Motion management
JAN CD-FC242	DTN10260	MG	Data distribution
JANCD-FC300B-3	DTN8570	AX1	Feed control: 3 axes
JANCD-FC310-1	DTN6720	AX2	Spindle control: 1 axis

.Model CPS-12N

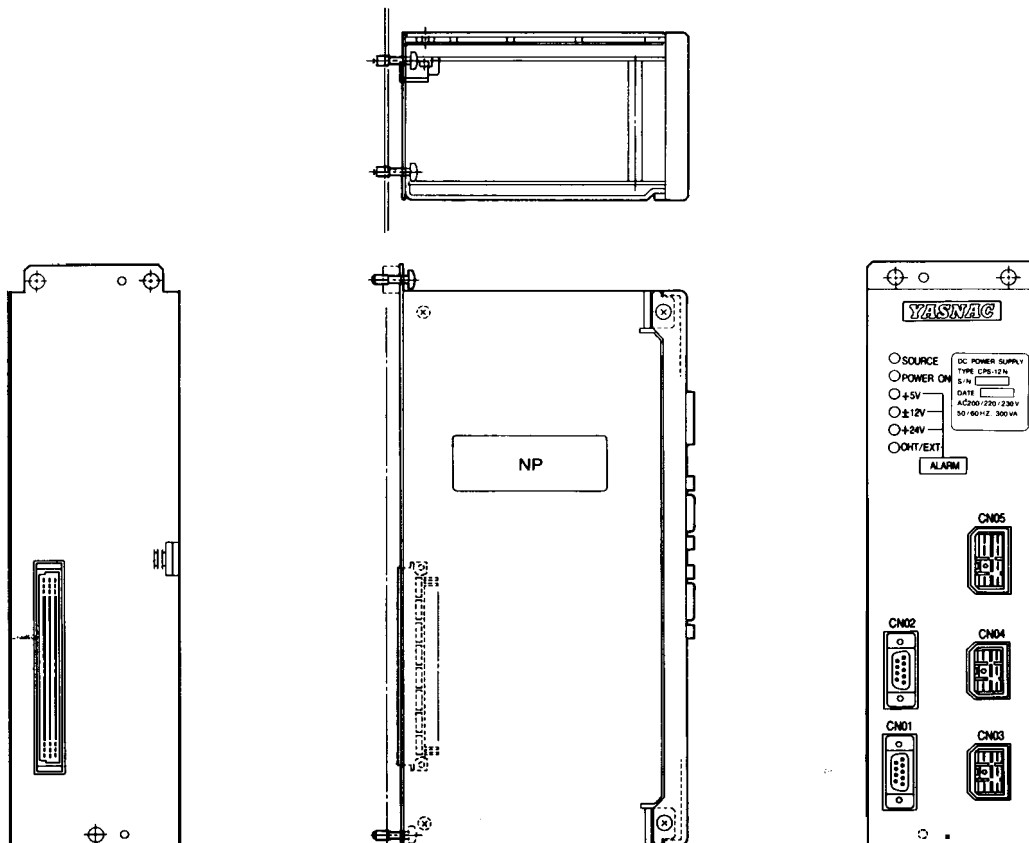

Approx. mass :1.52 kg

1.2 COMPONENTS (Cont'd)

- AMGC12 Slot Back B a d (Model JANCD-FC001)

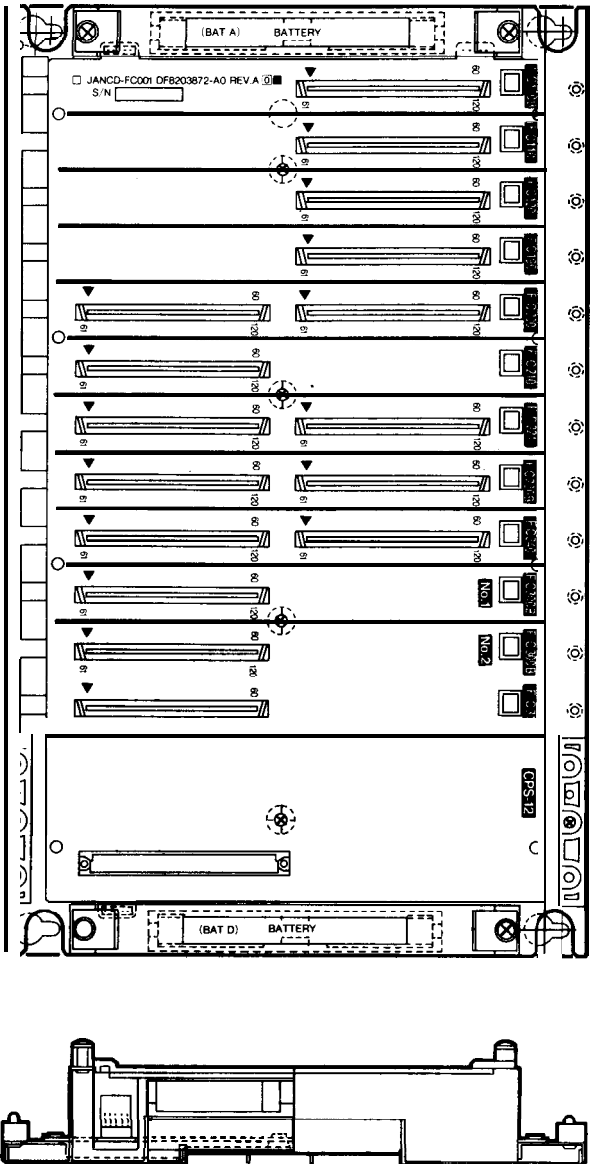

Approx. mass : 2.26 kg

- 9" Monochrome CRT/Keyboard Interface (Model JANCD-FC100C)

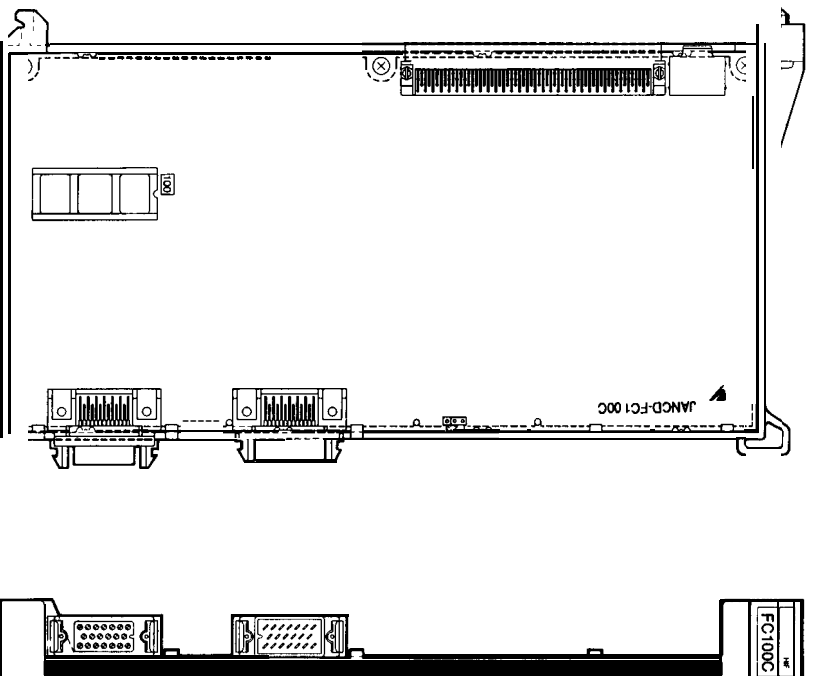

Approx. mass : 0.26 kg

.Model
JAN CD-FC190-1

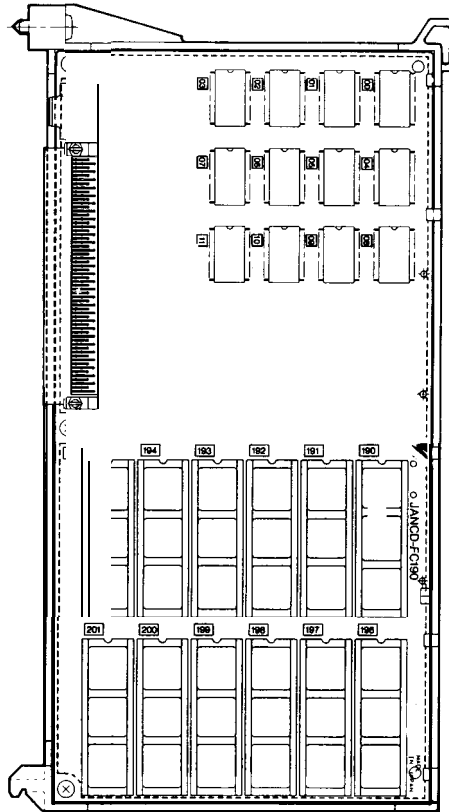

Approx. mass :0.32 kg



a

.Model
JAN CD-FC200

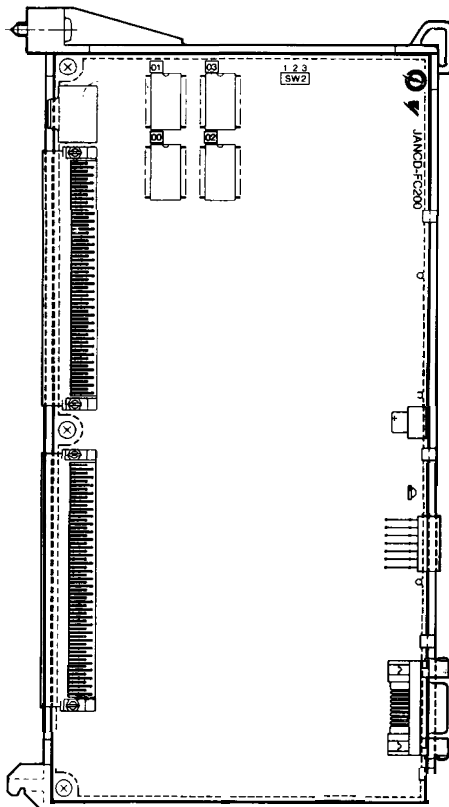

Approx. mass :0.3 kg

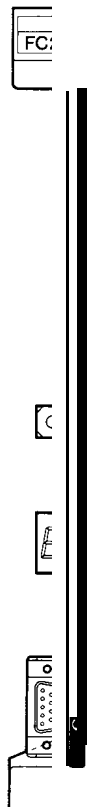

1.2 COMPONENTS (Cent'd)

- **Sequence Controller**
(Model JANCD-FC210-1)

Approx. mass :0.28 kg

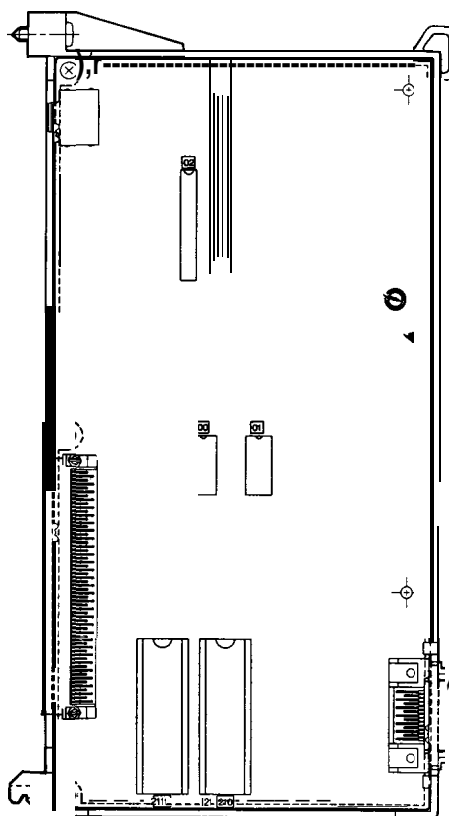

- **Model JAN CD-FC224**
(NC program analysis)

Approx. mass : 0.42kg

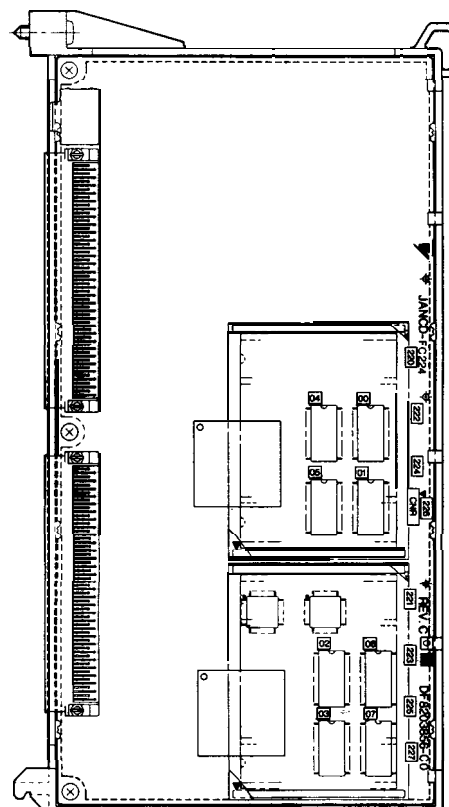

.ROM Board (Model JANCD-FC221)

Approx. mass :0.07 kg

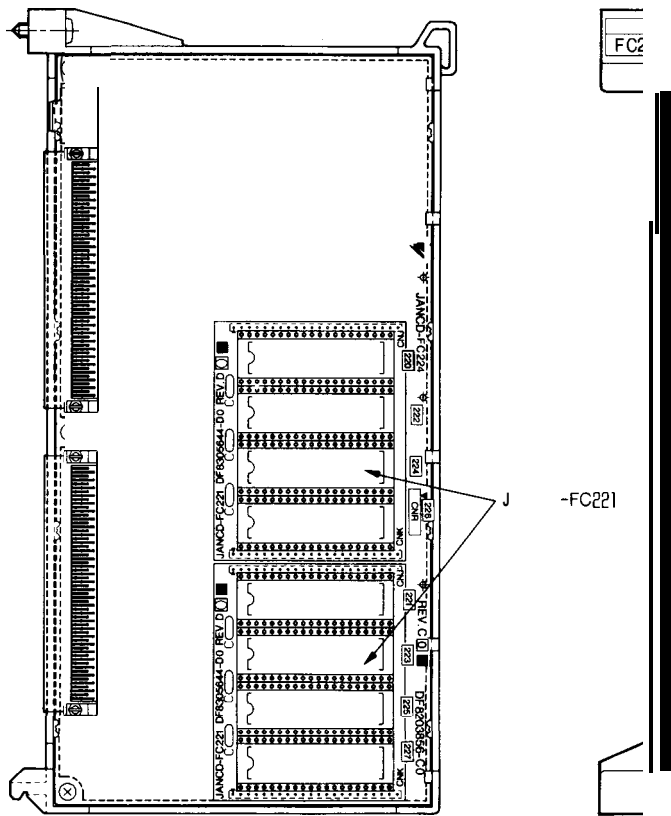

.Model JANCD-FC230B

Approx. mass :0.28 kg

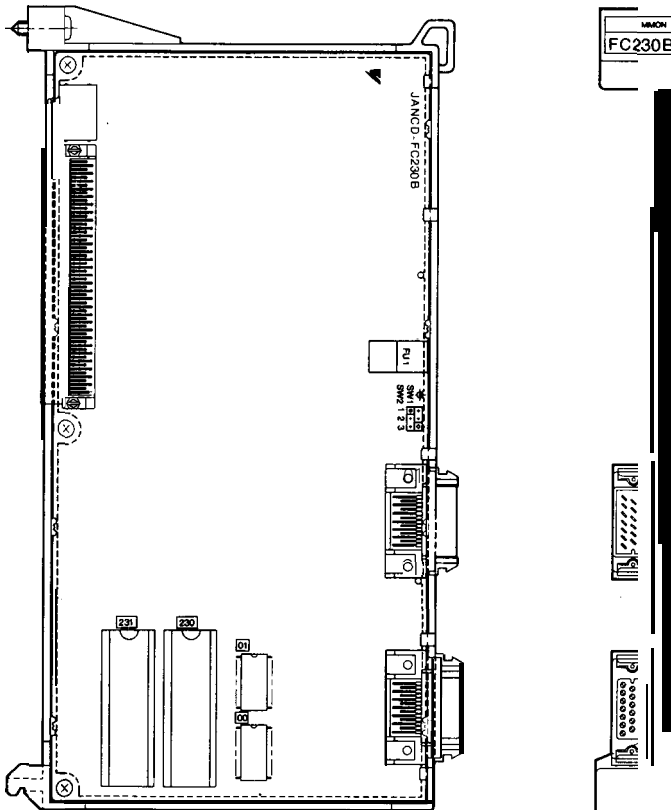

1

1.2 COMPONENTS (Cent'd)

.Model JANCD-FC242

Approx. mass :0.26 kg

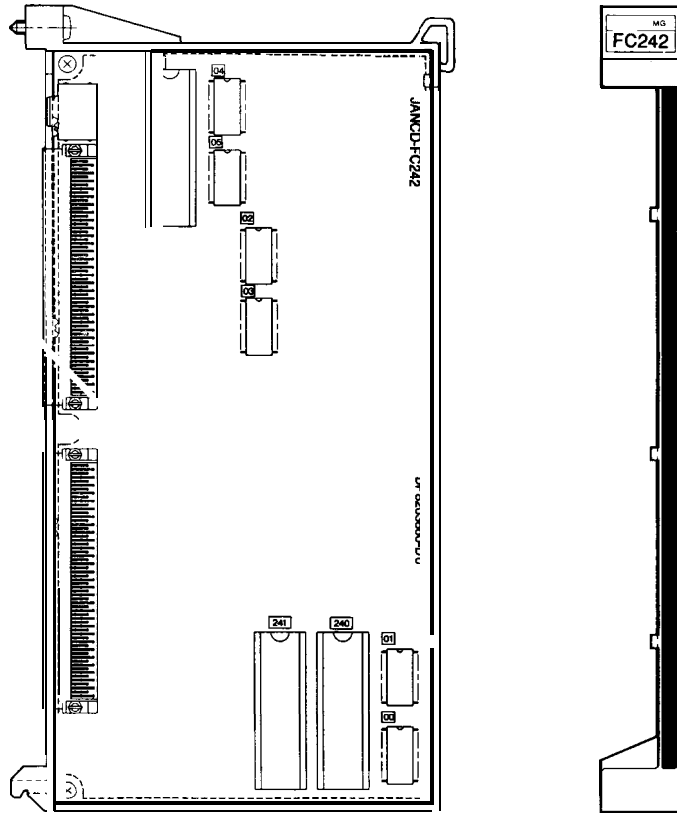

.Model JANCD-FC300B- 3 (Feed control: 3 axes)

Approx. mass :0.34 Kg

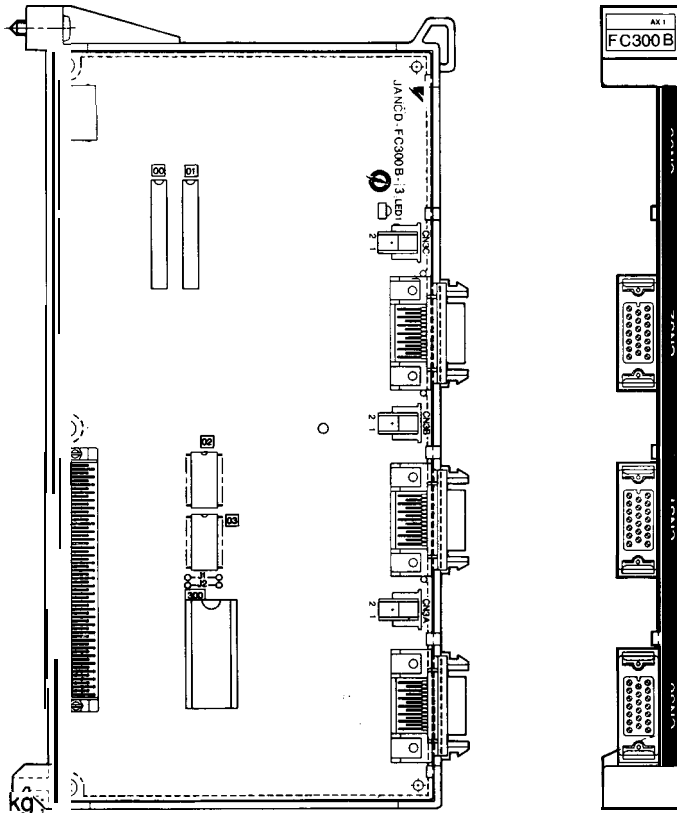

.Model JAN CD- FC310-1 (Spindle control: 1 axis)

a

Approx. mass :0.24 kg

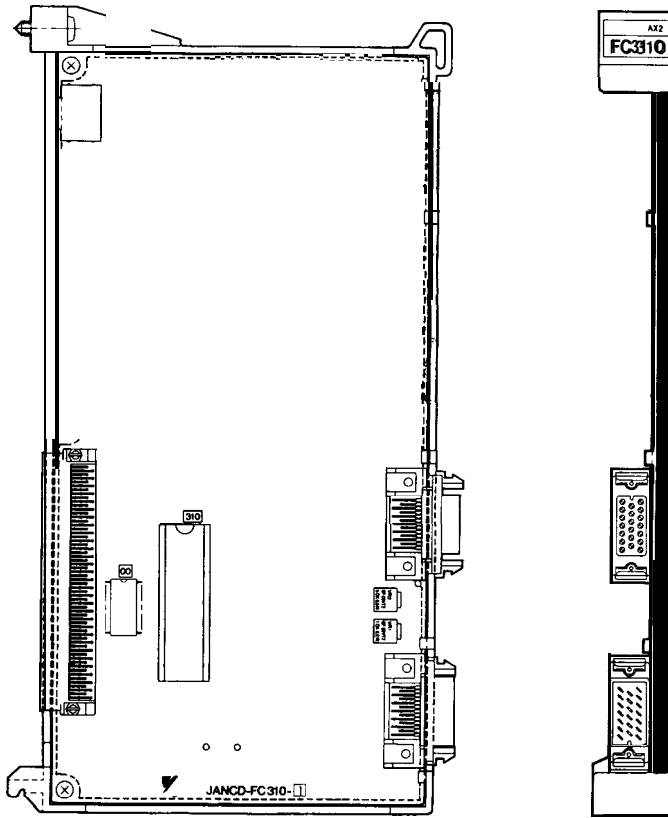

1.2 COMPONENTS (Cent'd)

(3) JZNC-IRK04 Module

Table 1.3 JZNC-IRK04 Module

Model	Supply Code	Abbreviation	Remarks
CPS-16F	AVR843	CPS	+5V 21A, +24V 1.5A, +12V 1.3A, -12V 0.3A
JAN CD-FC002	DTN8070	BB2	AMGC14 slot back board
JAN CD-F C100C	DTN9770	HIF	9" monochrome CRT/keyboard interface
JAN CD-F C190-1	DTN7020	SMEM	FC200 memory RAM 384kB
JAN CD-FC200	DTN6470	SMON	System management
JAN CD-F C210-1	DTN6850	PLC	Sequence controller, without RS-232C
JAN CD-FC222	DTN8110	INTEX2	NC program analysis
JAN CD-FC221	DTN8010	ROMS	ROM board (two boards for model FC222 are used)
JAN CD-F C230B	DTN8490	MMON	Motion management
JAN CD-FC241	DTN8520	MG2	Data distribution
JANCD-FC300B-3	1) TN8570	A X 1	Feed control: 3 axes
JANCD-FC310-2	DTN6730	AX2	Spindle control: 2 axes

- Model CPS-16F

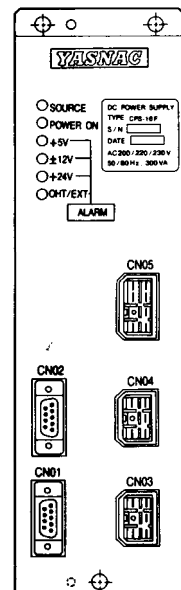
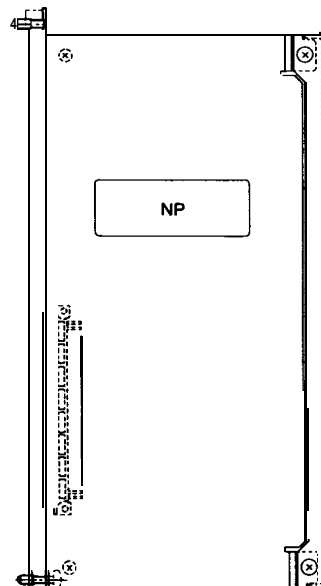
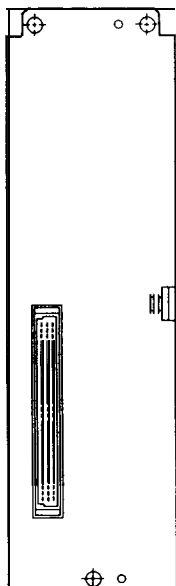
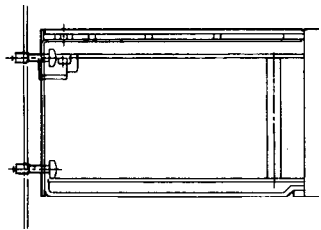

.AMGC14 Slot Back Board (Model JAN CD-FC002)

1

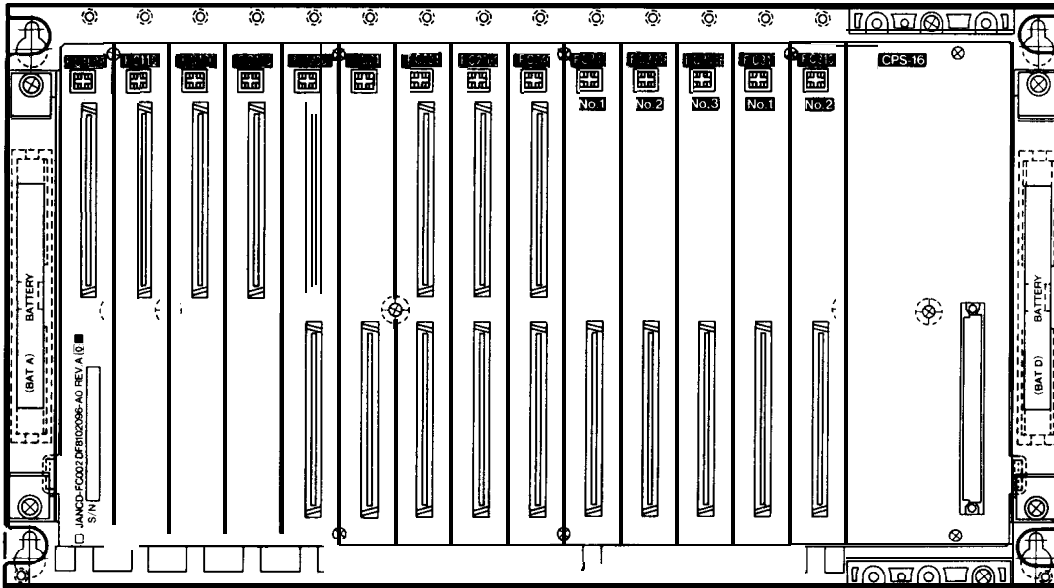

Approx. mass :2.26 kg

- | | | |
|-----------------|----------------|------------------|
| •JANCD-FC100C | •JANCD-FC210-1 | •JANCD-FC230B |
| • JANCD-FC190-1 | • JANCD-FC221 | • JANCD-FC300B-3 |
| • JANCD-FC200 | | |

For the models description shown above, see Table 1.2, and for the model JANCD-FC222, see Table 1.11.

1.2 COMPONENTS (Cent'd)

- Model JAN CD-FC310-2 (Spindle control: 2 axes)

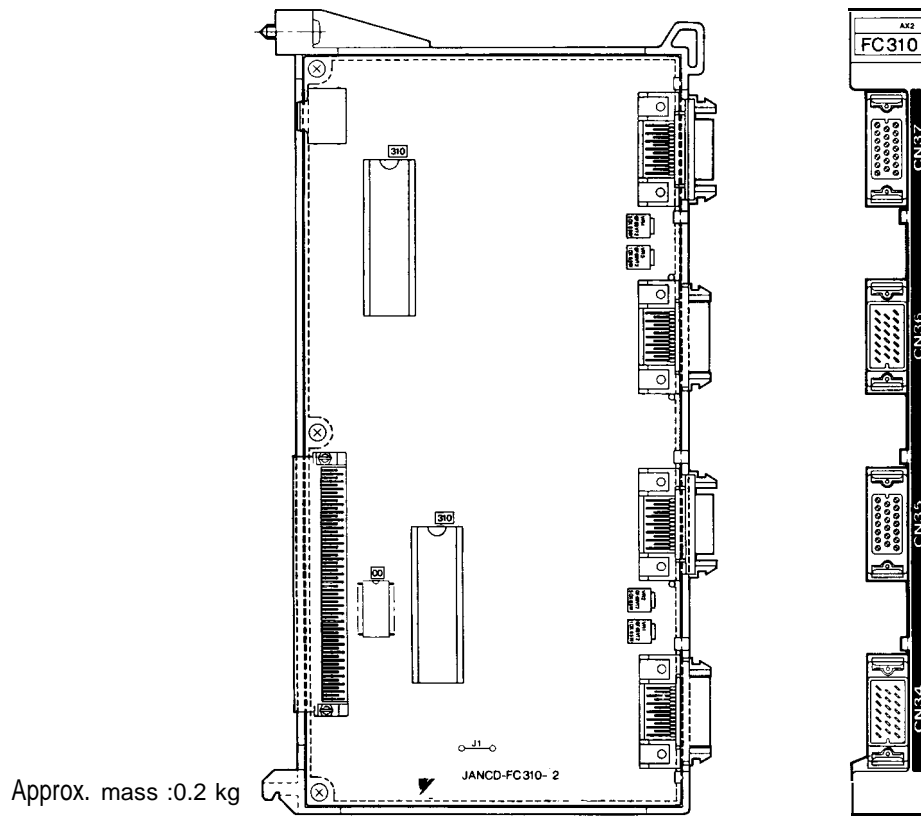

.Model JAN CD-FC241

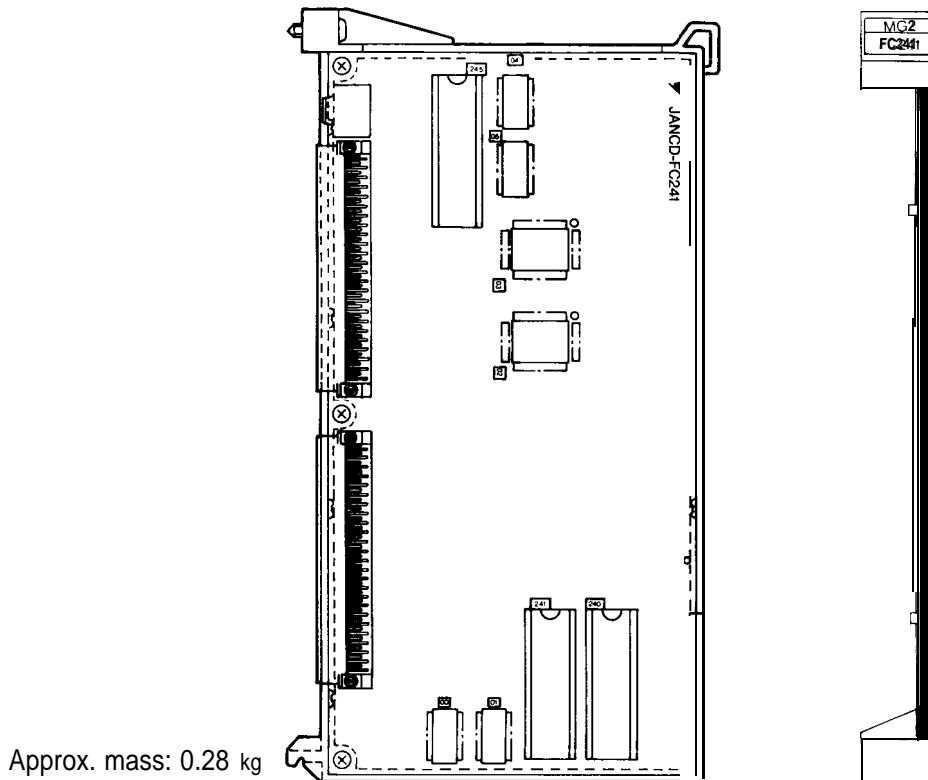

(4) JZNC-IRK31 Module

Table 1.4 JZNC-IRK31 Module

Model	Supply Code	Abbreviation	Remarks
CPS-12N	AVR0842	CPS	+5V 13A, +24V 1.5A, +12V 1.3A, -12V 0.3 A
JAN CD- FC006	DTN10230	BB3	AMGC11 slot back board
JAN CD-F C100C	DTN9770	HIF	9" monochrome CRT/keyboard interface
JAN CD- FC191-1	DTN10030	SMEM2	FC200 memory RAM 384kB
JAN CD- FC200	DTN6470	SMON	System management
JAN CD- FC210-1	DTN6850	PLC	System controller, without RS-232C
JAN CD- FC250	DTN10180	INTEXB	NC program analysis
JAN CD-F C260-1	DTN10200	MOTION	Motion management, data distribution, spindle control: 1 axis
JAN CD-F C300B-3	DTN8570	AX1	Feed control: 3 axes

.Model JANCD-FC006

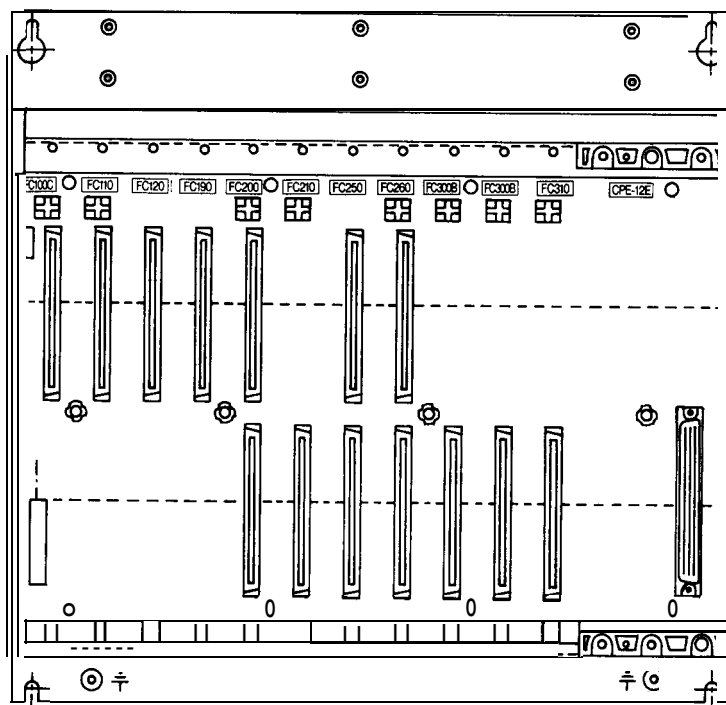

Approx. mass :4.93 kg

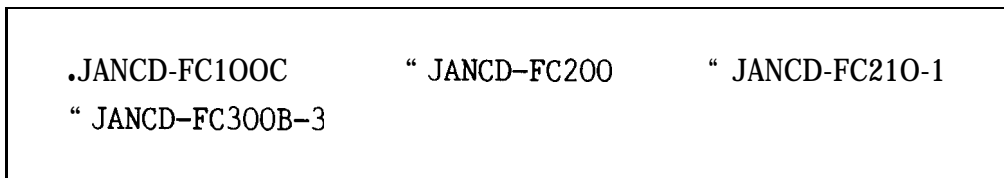

For the models description shown above, see Table 1.2.

1.2 COMPONENTS (Cent'd)

• Model JANCD-FC191-1

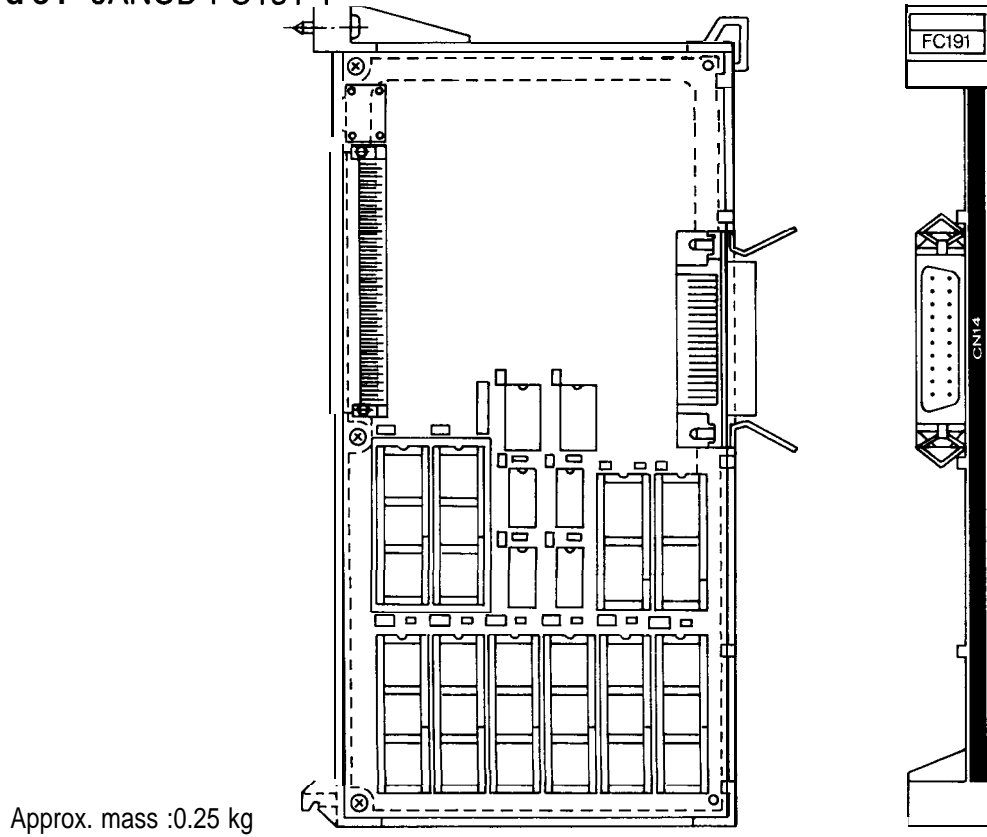

• Model JANCD-FC250

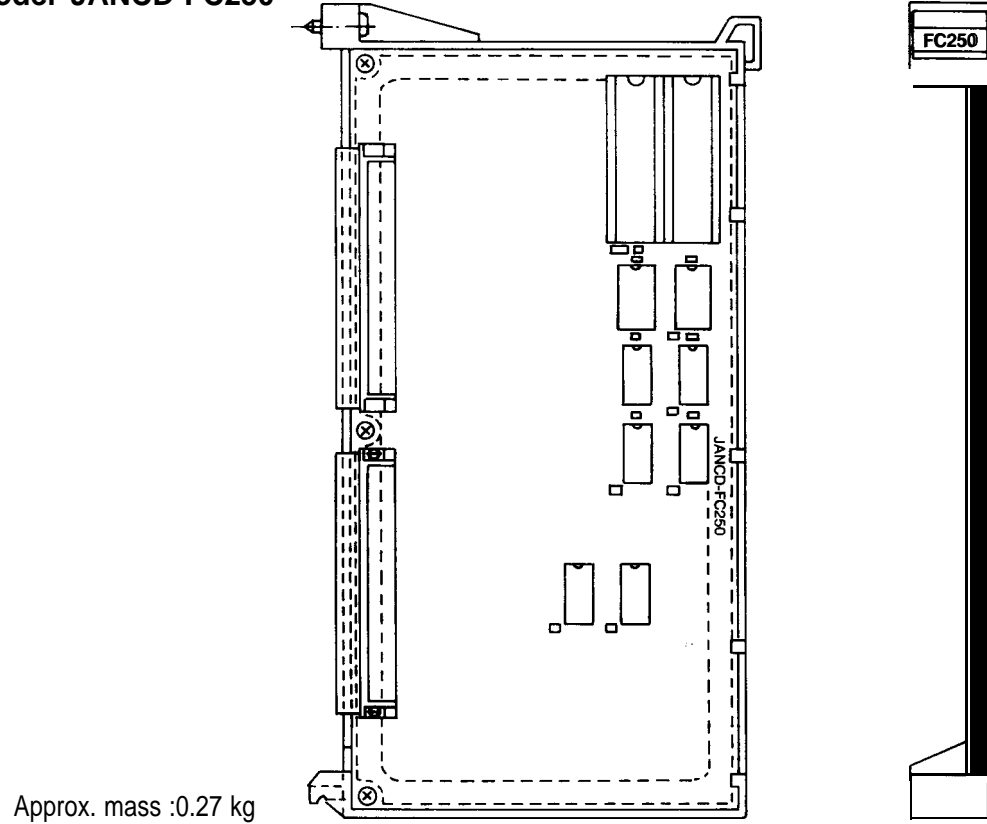

▪ Model JANCD-FC260-I

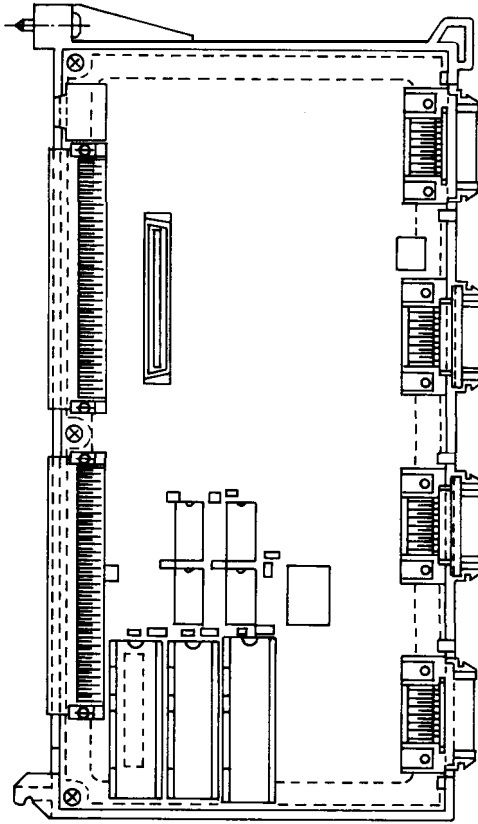

Approx. mass :0.34 kg

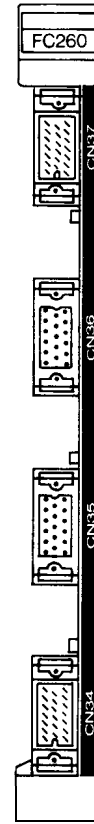

1.2 COMPONENTS (Cent'd)

(5) JZNC-IRK41 Module

Table 1.5 JZNC-IRK41 Module

Type	Supply Code	Abbreviation	Remarks
CPS-12N	AVR0842	CPS	+5V 13A, +24V 1.5A, +12V 1.3A, -12V 0.3A
JAN CD- FC006	DTN10230	BB3	AMGC11 slot back board
JAN CD- FC100C	DTN9770	HIF	9" monochrome CRT/keyboard interface
JAN CD-F C191-1	DTN10030	SMEM2	FC200 memory RAM384kB
JAN CD- FC200	DTN6470	SMON	System management
JAN CD-F C210-1	DTN6850	PLC	Sequence controller, without RS-232C
JAN CD- FC250	DTN10180	INTEXB	NC program analysis
JAN CD-F C260-1	DTN10200	MOTION	Motion management, data distribution, spindle control: 1 axis
JAN CD- FC300B-3	DTN8570	AX1	Feed control: 3 axes
JAN CD-F C310-1	DTN6730	AX2	Spindle control: 3 axes

•JANCD-FC100C	“ JANCD-FC200	“ JANCD-FC210-1
“ JANCD-FC300B-3	“ JANCD-FC310-1	

For the models description shown above, see Table 1.2.

“ JANCD-FC006	“ JANCD-FC191-1	“ JANCD-FC250
•JANCD-FC260		

For the models description shown above, see Table 1.4.

.Model JANCD-FC251

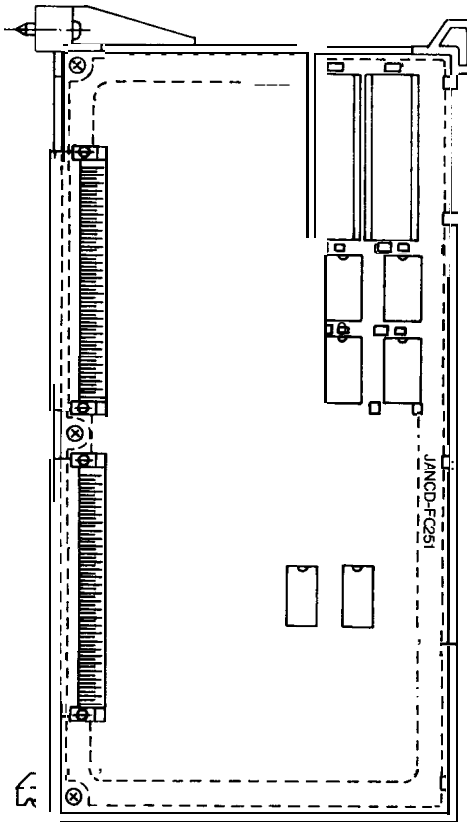

Approx. mass :0.27 kg



. M o d e l JANCD-FC265

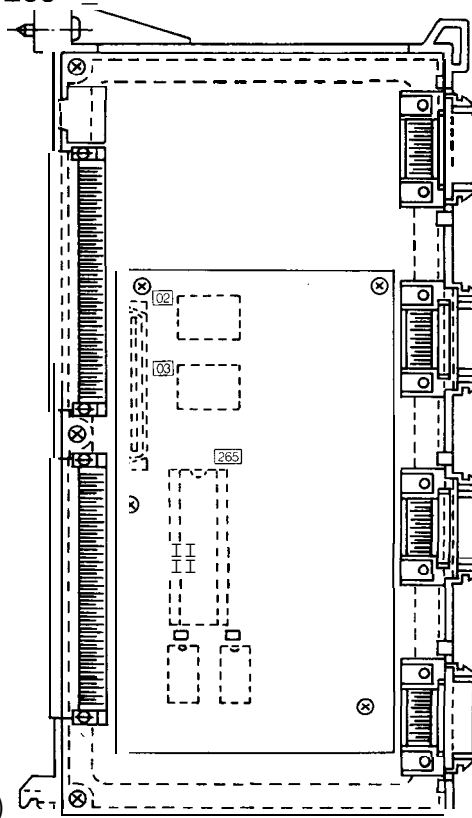

Approx. mass :0.11 kg
(only JANCD-FC265 board)

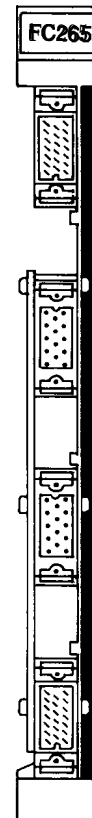

This figure shows model JANCD-FC265 attached to model JANCD-FC260.

1.2 COMPONENTS (Cent'd)

(6) JZNC-IRK76 Module

Table 1.6 JZNC-IRK76 Module

Model	Supply Code	Abbreviation	Remarks
CPS-16F	AVR843	CPS	+5V 21A, +24V 1.5A, +12V 1.3A, -12V 0.3A
JAN CD-FC050	DTN8030	ABB1	ACGC16 slot back board
JAN CD-F C190-1	DTN7020	SMEM	FC200 memory RAM 384kB
JAN CD-FC200	DTN6470	SMON	System management
JAN CD- FC210-1	DTN6850	PLC	Sequence controller, without RS-232C
JAN CD-FC224	DTN9450	INTEX3	NC program analysis
JAN CD- FC221	DTN8010	ROMS	ROM board (two boards for model FC224 are used)
JAN CD-F C230B	DTN8490	MMON	Motion management
JAN CD-FC240	DTN6530	MG	Data distribution
JAN CD-F C300B-3	DTN8570	AX1	Feed control: 3 axes
JAN CD- FC310-1	DTN6720	AX2	Spindle control: 1 axis
JANCD-FC400	DTN7090	NIF	ACGC-NC interface module
JANCD-FC410	DTN7080	ACP	ACGC main module
JAN CD-FC221	DTN8010	ROMS	ROM board (two pieces for FC410 are used)
JANCD-FC420	DTN8040	GIF	ACGC graphic control module
JAN CD-FC430	DTN7060	APM1	ACGC application memory module
JAN CD-FC440	DTN7070	APM2	ACGC application memory module

• ACCG16 S ot Back Board (Mode JANCD-FC050)

1

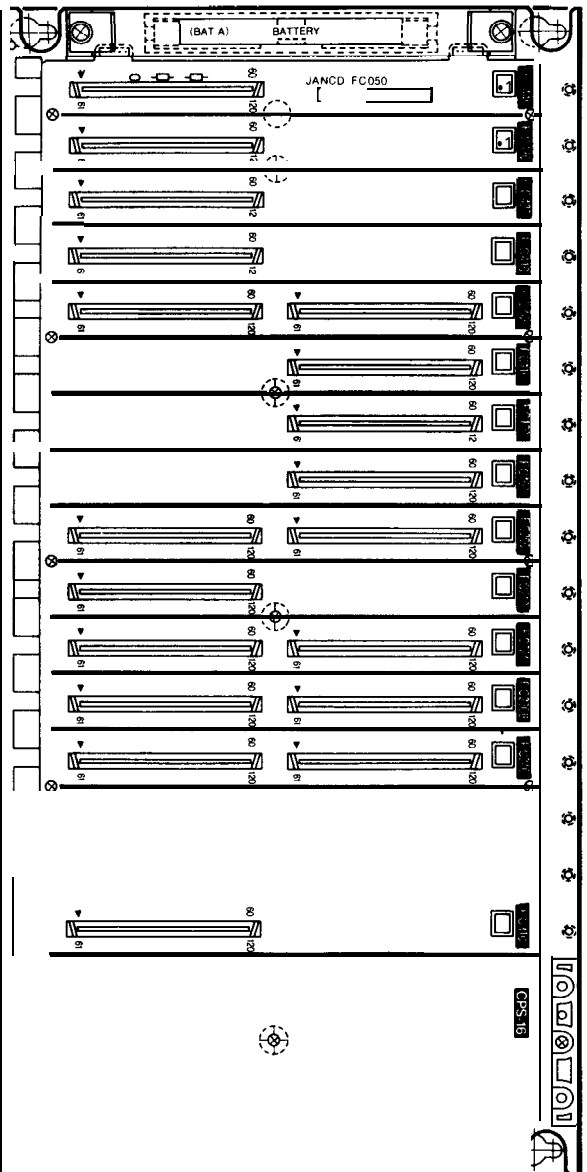

▪ JANCD-FC190-1	• JANCD-FC224	• JANCD-FC240
▪ JANCD-FC200	• JANCD-FC221	• JANCD-FC300B-3
▪ JANCD-FC210-1	• JANCD-FC230B	• JANCD-FC310-1

For the models description shown above, see Table 1.2.

1.2 COMPONENTS (Cent'd)

- **ACGC-NC Interface module (Model JAN CD-FC400)**

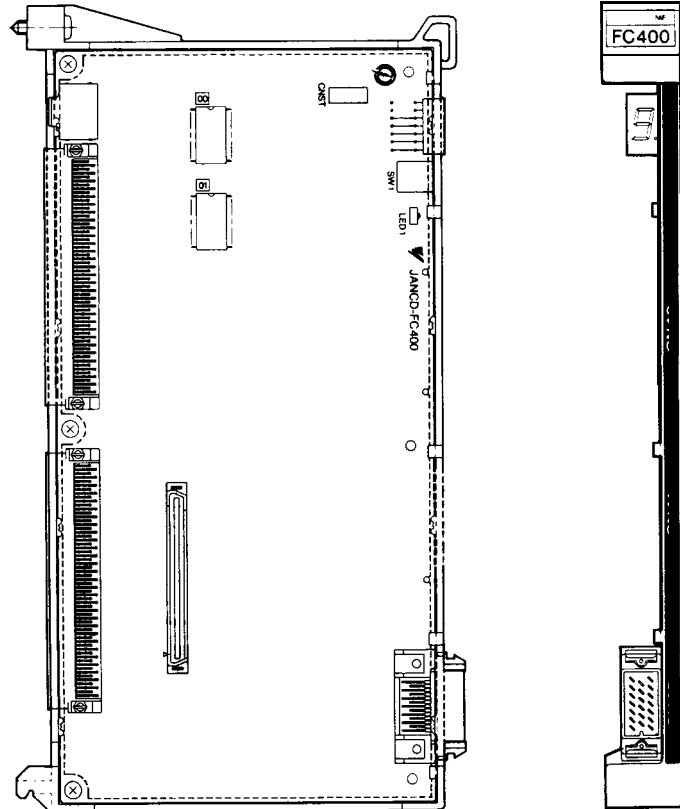

Approx. mass :0.28 kg

- **ACGC Main Module (Model JANCD-FC410)**

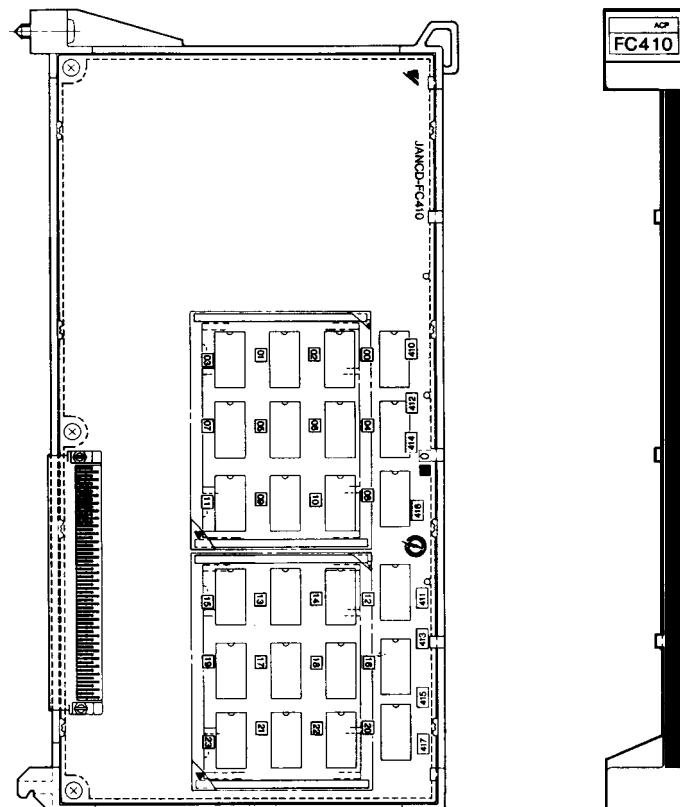

Approx. mass :0.46 kg

.ROM Board (Model JANCD-FC221)

Approx. mass :0.07 kg

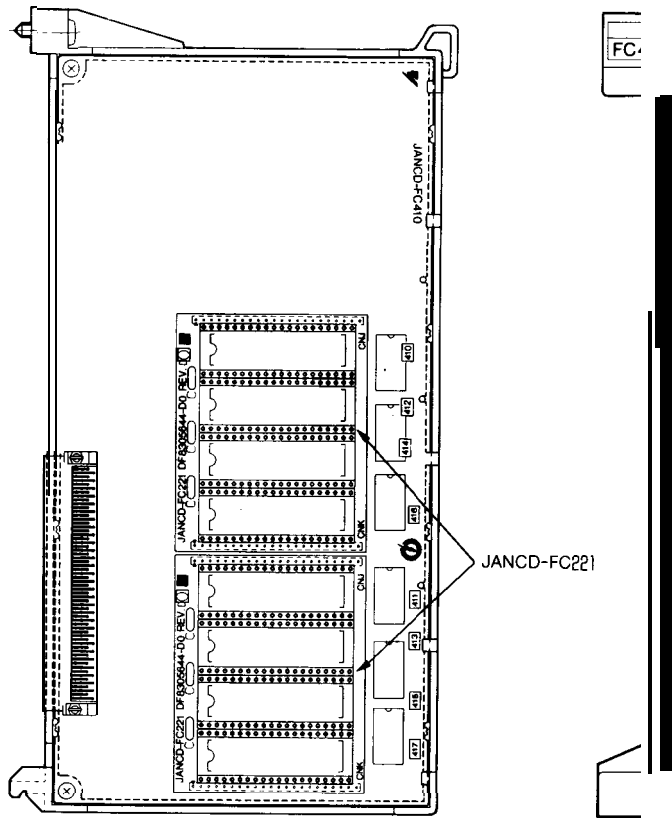

.ACGC Graphic Control Module (Model JANCD-FC420)

Approx. mass :0.28 kg

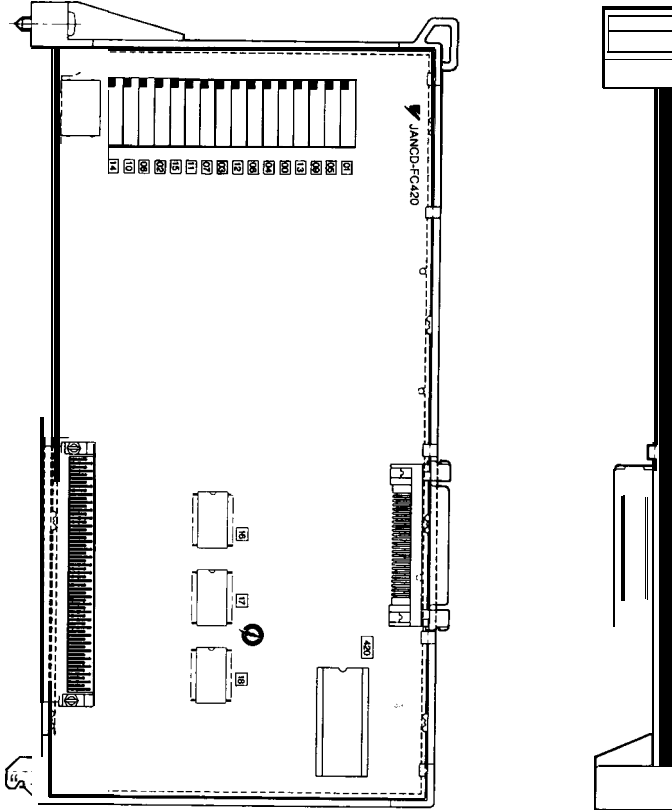

1.2 COMPONENTS (Cent'd)

.ACGC Application Memory Module (Model JANCD-FC430)

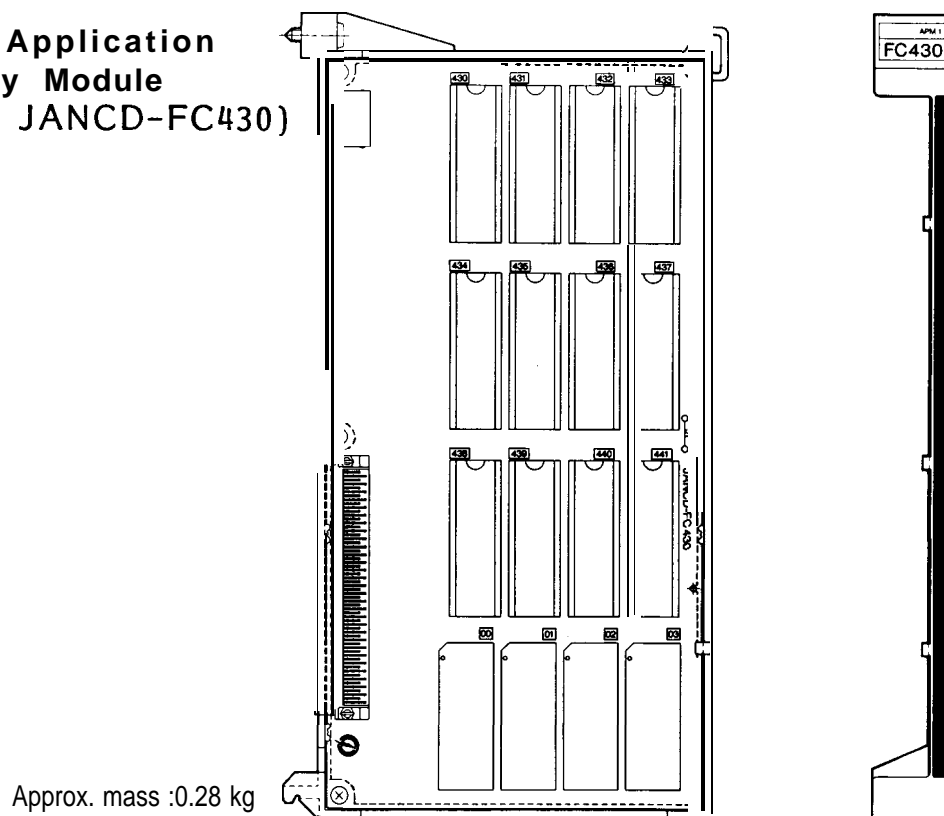

.ACGC Application Memory Module (Model JANCD-FC440)

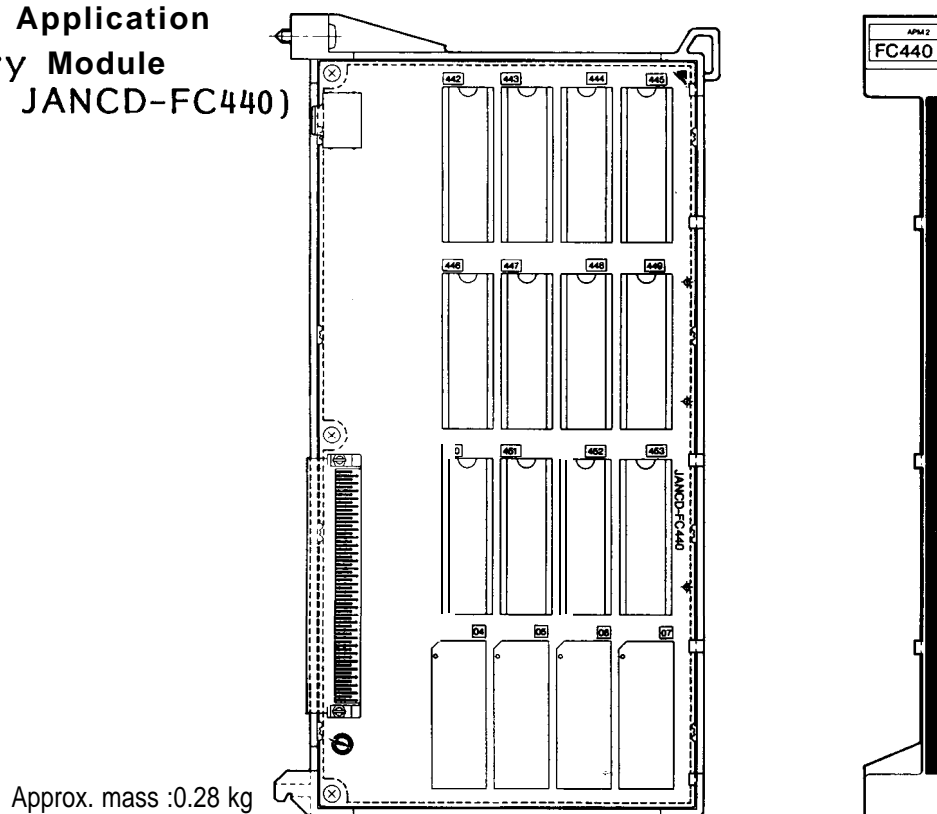

(7) JZNC-IRK58 Module

Table 1.7 JZNC-IRK58 Module

a

Model	Supply Code	Abbreviation	Remarks
CPS-16F	AVR843	CPS	+5V 21A, +24V 1.5A, +12V 1.3A, -12V 0.3A
JANCD-FC052	DTN8030	ABB2	ACGC18 slot back board
JAN CD- FC190-1	DTN7020	S MEM	FC200 memory RAM 384kB
JAN CD-FC200	DTN6470	S M O N	System management
JANCD-FC210-1	DTN6850	PLC	Sequence controller, without RS-232C
JAN CD-FC222	DTN8110	INTEX2	NC program analysis
JAN CD- FC221	DTN8010	ROMS	ROM board (two boards for model FC222 are used)
JAN CD- FC230B	DTN8490	M M O N	Motion management
JAN CD-FC241	DTN8520	MG	Data distribution
JANCD-FC300B-3	DTN8570	A X 1	Feed control: 3 axes
JANCD-FC310-2	DTN6730	A X 2	Spindle control: 2 axes
JANCD-FC400	DTN7090	NIF	ACGC-NC interface module
JAN CD-FC410	DTN7080	ACP	ACGC main module
JANCD-FC221	DTN8010	ROMS	ROM board (two pieces for FC410 are used)
JANCD-FC420	DTN8040	GIF	ACGC graphic control module
JAN CD-FC430	DTN7060	APM1	ACGC application memory module
JAN CD- FC440	DTN7070	APM2	ACGC application memory module

1.2 COMPONENTS (Cent'd)

.Model JAN CD-FC052

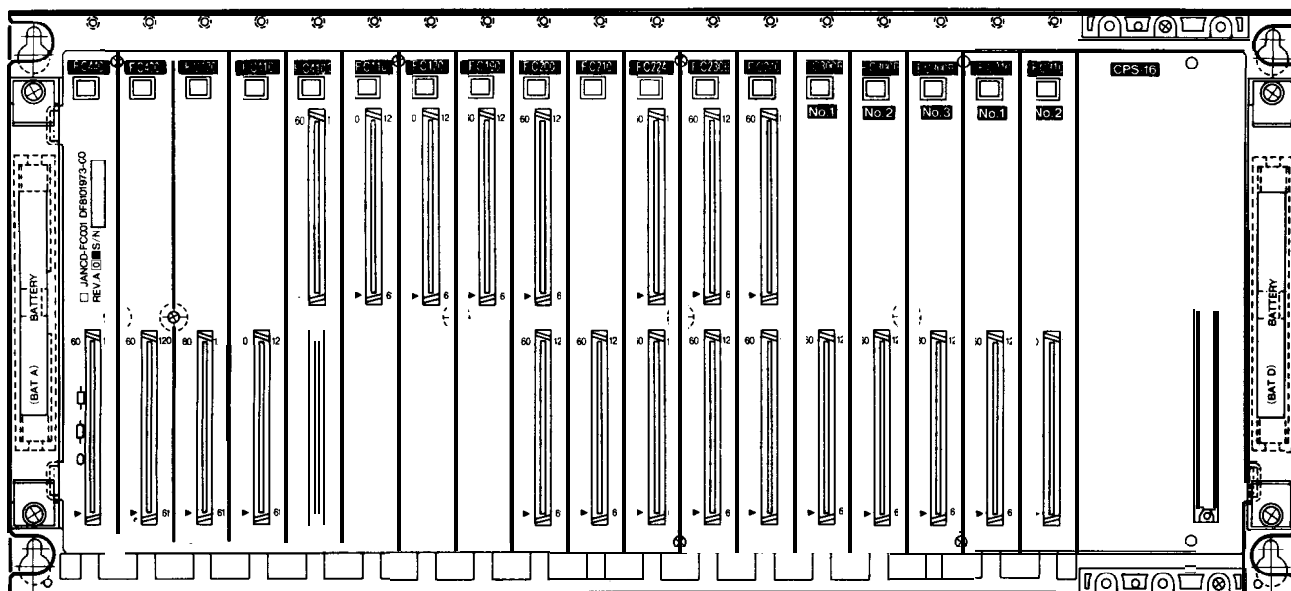

- JANCD-FC190-1
- JANCD-FC200
- JANCD-FC210-1
- JANCD-FC221
- JANCD-FC230B
- JANCD-FC300B-3

For the models description shown above, see Table 1.2.

- JANCD-FC241
- JANCD-FC310-2

For the models description shown above, see Table 1.3.

- JANCD-FC400
- JANCD-FC410
- JANCD-FC221
- JANCD-FC420
- JANCD-FC430
- JANCD-FC440

For the models description shown above, see Table 1.6.

(8) JZNC-IOP01 E Module

Table 1.8 JZNC-IOP01E Module

Model	Supply Code	Abbreviation	Remarks
JAN CD- FC900B-1	DTN8500	SP	Panel interface (for CRT)
JAN CD-FC901	DTN6670	FKEY	Function keyboard
JAN CD-F C903-1	DTN8080	PI02	Panel I/O IHPG
MD T948B-3B	CRT16		9" monochrome graphic CRT unit
DE9400035	SW825		Keyboard unit

.Panel Interface (Model JANCD-FC900B)

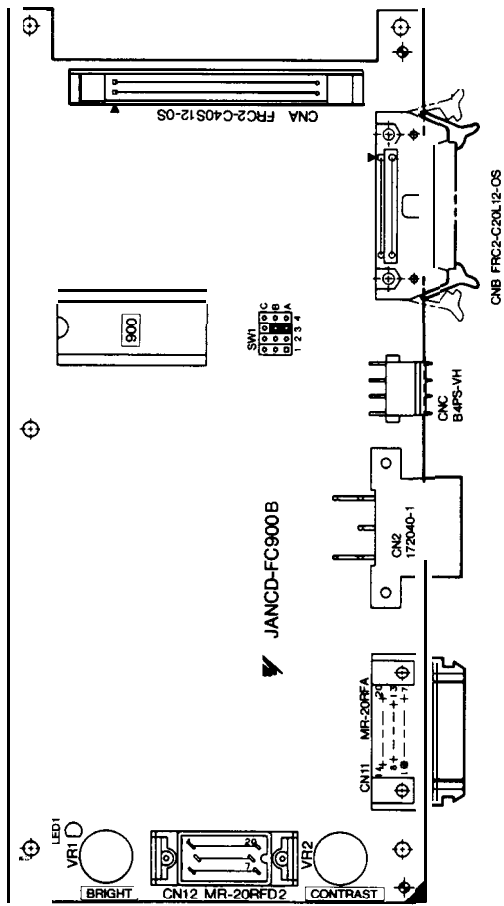

Approx. mass :0.2 kg

.Panel I/O (Model JANCD-FC903-1)

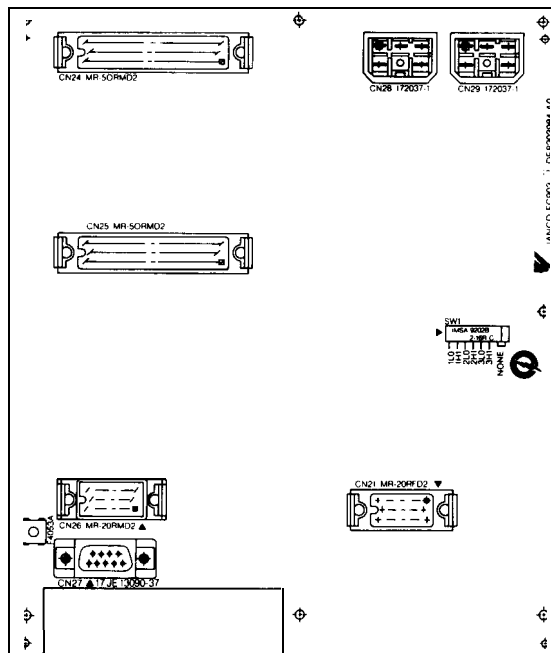

Approx. mass :0.3 kg



1.2 COMPONENTS (Cent'd)

(9) JZNC-IOPI 1 E Module

Table 1.9 JZNC-IOP11 E Module

Model	Supply Code	Abbreviation	Remarks
JAN CD-F C950-1	DTN8190	ASP	Panel interface
JAN CD-FC951	DTN8050	FKEY	Function keyboard
TX1424AD	CRT13		14" monochrome graphic CRT unit
DE8412739	SW826		Keyboard unit

.Panel Interface (Model JANCD-FC950-1)

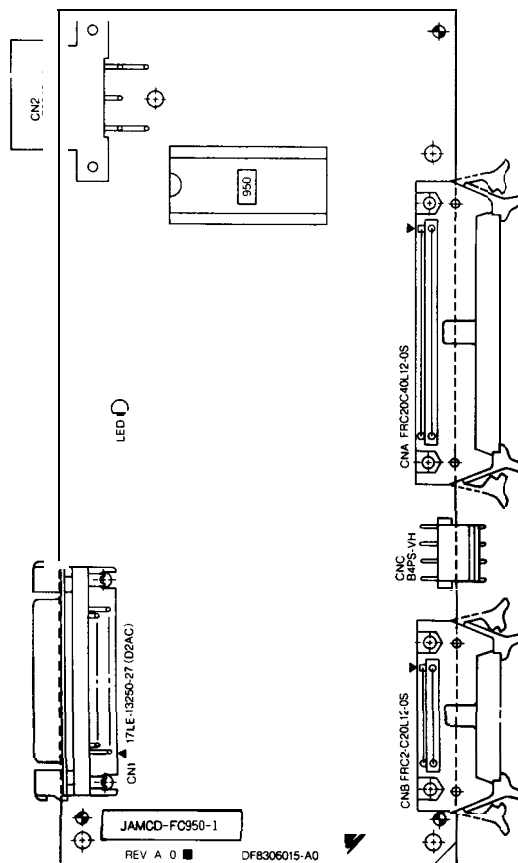

Approx. mass :0.18 kg

(1 O) JZNC-IAU51 Module

Table 1.10 JZNC-IAU51 Module

Model	Supply Code	Abbreviation	Remarks
MO DE L2801 B-2	RED18		RS-232C tape reader
EYG300/55GTL	AVR904		Composite power for 5/24V tape reader
MOD EL1500	RED14		Option
MODEL1402-1	RED13		Option

(11) Option Modules

Table 1.11 Option Modules

Model	Supply Code	Abbreviation	Remarks
JAN CD-FC110	DTN6450	COM	Communication module
JAN CD-F C120-1	DTN6370	FILE	Expanded RAM 64kB (320 m)
JAN CD- FC120-2	DTN6760	FILE	Expanded RAM 192kB (640 m)
JAN CD- FC120-3	DTN6770	FILE	Expanded RAM 448kB (1280 m)
JAN CD-F C120-4	DTN6980	FILE	Expanded RAM 960kB (2560 m)
JAN CD-F C120-5	DTN6990	FILE	Expanded RAM 1984kB (5120 m)
JAN CD-F C190-2	DTN7030	SMEM	FC200 memory RAM 512kB
JAN CD- FC191-2	DTN10040	SMEM2	FC200 memory RAM 640kB
JAN CD- FC191-3	DTN10050	SMEM2	FC200 memory RAM 384kB, with printer I/F
JAN CD- FC191-4	DTN10060	SMEM2	FC200 memory RAM 640kB, with printer I/F
JAN CD- FC210-2	DTN6500	PLC	Sequence controller 2 CH RS-232C
JAN CD-FC222	DTN8110	INTEX2	NC program analysis (With extended CPU)
JAN CD-F C245-1	DTN6820	FG	Interpolation computing element x 1
JAN CD-F C245-2	DTN6590	FG	Interpolation computing element x 2
JANCD-FC251	DTN10180	INTEXB2	NC program analysis (with high-performance CPU)
JANCD-FC260-2	DTN10240	MOTION	Motion management, data distribution, without spindle control
JANCD-FC265	DTN10210	FG2	Interpolation calculator (for FC 260)
JANCD-FC301-3	DTN6660	LIF	Linear scale interface: 3 axes
JANCD-FC401	DTN7050	FDC	Floppy disk control
JANCD-FC470	DTN7040	ARM	ACGC debug memory module
JANCD-FC801	DTN8160	ADM	Remote I/O A/D module
JANCD-FC802	DTN8170	DAM	Remote I/O A/D module
JAN CD- FC803-3	DTN8140	DLB	Branch board : 3 axes
JANCD-FC900B-2	DTN8530	SP	Panel interface (for EL)
JAN CD- FC903-2	DTN8090	PIo2	Panel I/O 2HPG
JANCD-FC903-3	DTN8100	PI02	Panel I/O 3HPG
JAN CD- FC950-2	DTN8200	ASP	Panel interface, video printer
JAN CD- FC950-3	DTN8210	ASP	Panel interface, JIS keyboard
JAN CD- FC950-4	DTN8220	ASP	Panel interface, video printer, JIS keyboard

1.2 COMPONENTS (Cent'd)

- **Communication Module
(Model JANCD-FC110)**

Approx. mass :0.31 kg

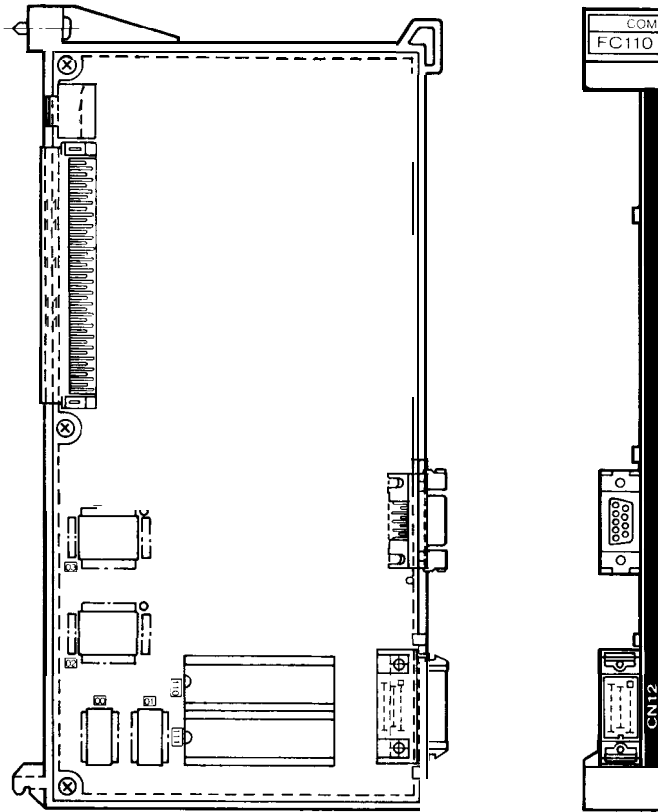

- **Expanded RAM
(Model JANCD-FC120)**

Approx. mass :0.27 kg

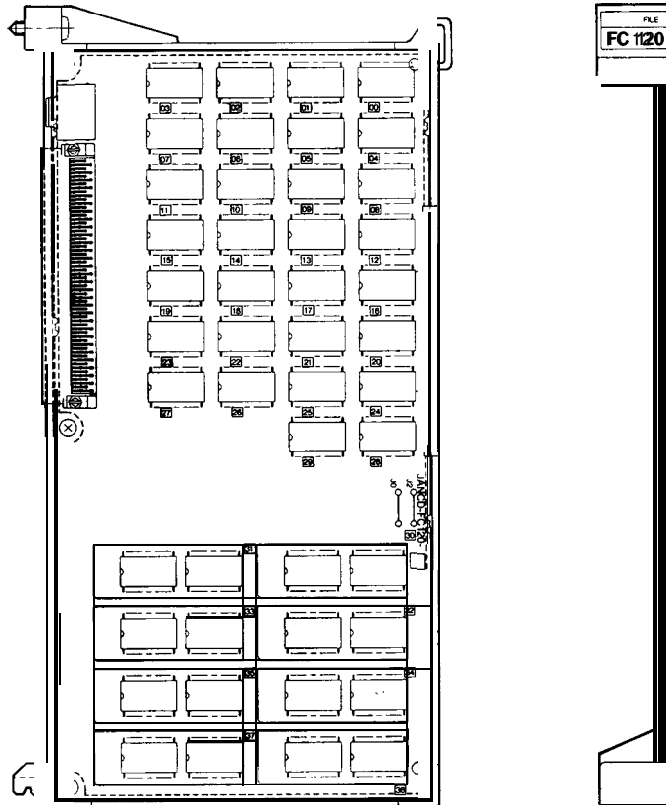

- **Sequence Controller
(Model JANCD-FC21 0-2)**

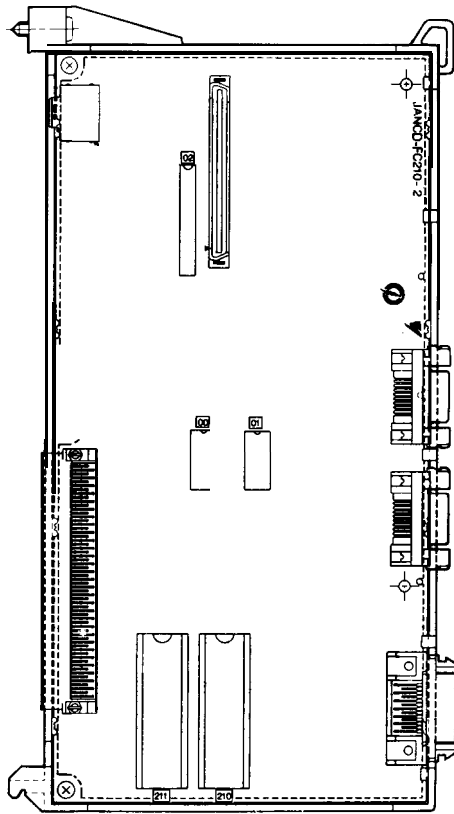

Approx. mass :0.32 kg

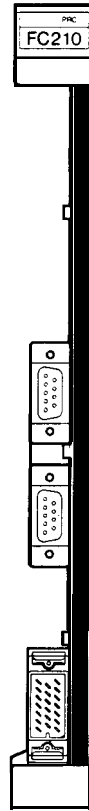

- **NC Program Analysis
(Model JANCD-FC222)**

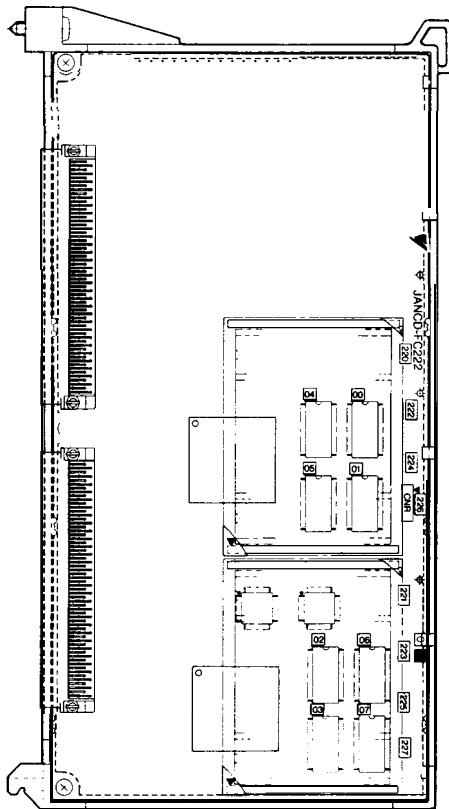

Approx. mass :0.42 kg



1.2 COMPONENTS (Cent'd)

.Floppy Disk Control (Model JANCD- FC401)

Note

This figure shows
model JANCD-FC401
attached to model
JANCD-FC400.

Approx. mass :0.22 kg

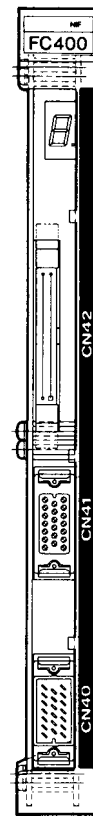
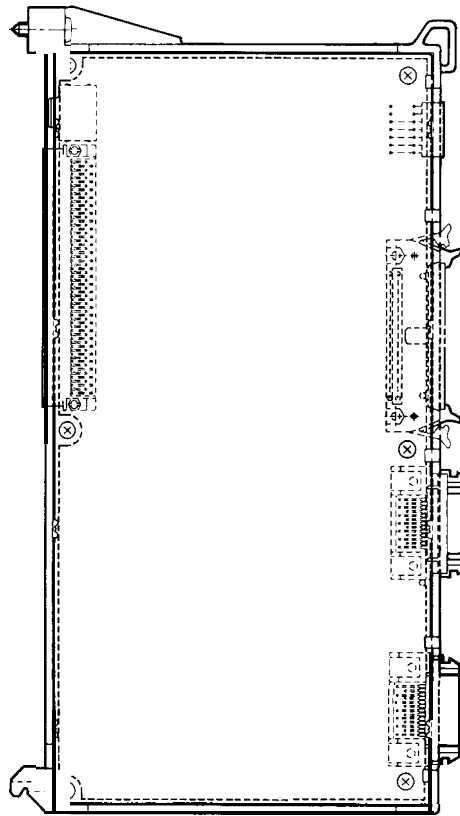

• ACGC Debug Memory Module (Model JANCD-FC470)

Approx. mass : 0.35kg

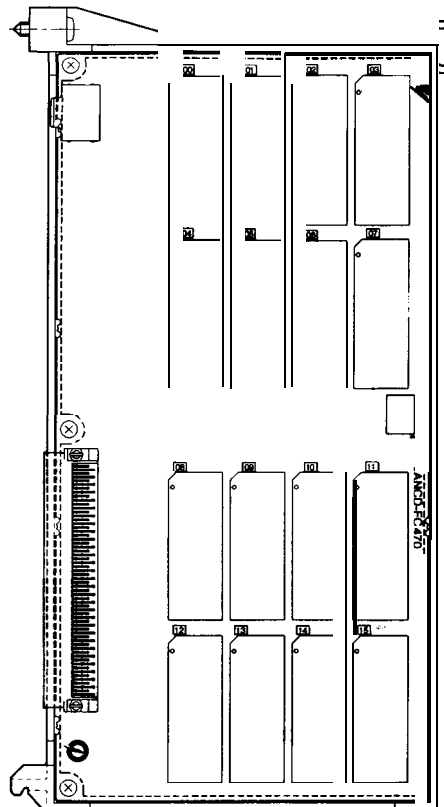

.Panel 1/0 (Models JAN CD-FC903-2 and -3)

1

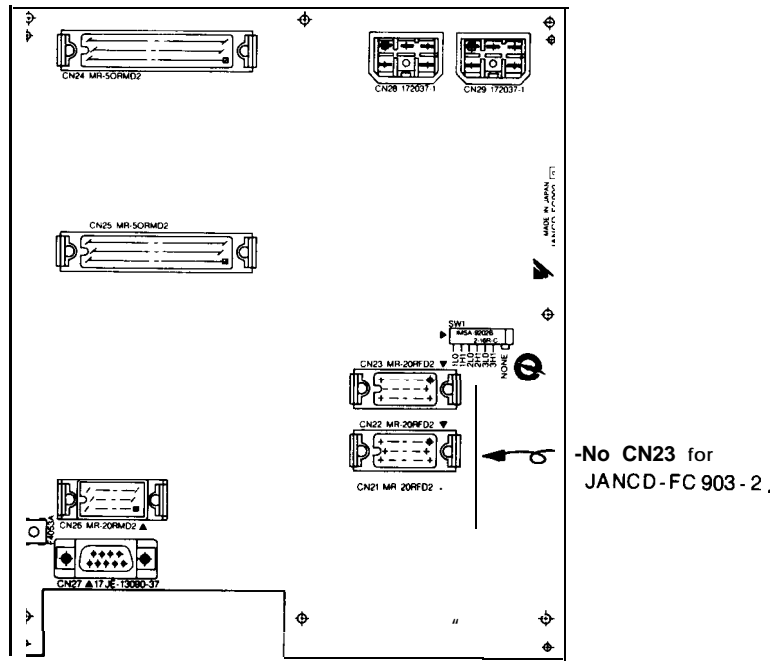

.Panel Interface (Models JAN CD-FC950-2, -3, and -4)

Note
 Model JANCD-FC950-2 has no CNE.
 Model JANCD-FC950-3 has no CND.
 Model JANCD-FC950-4 has CND and CNE.

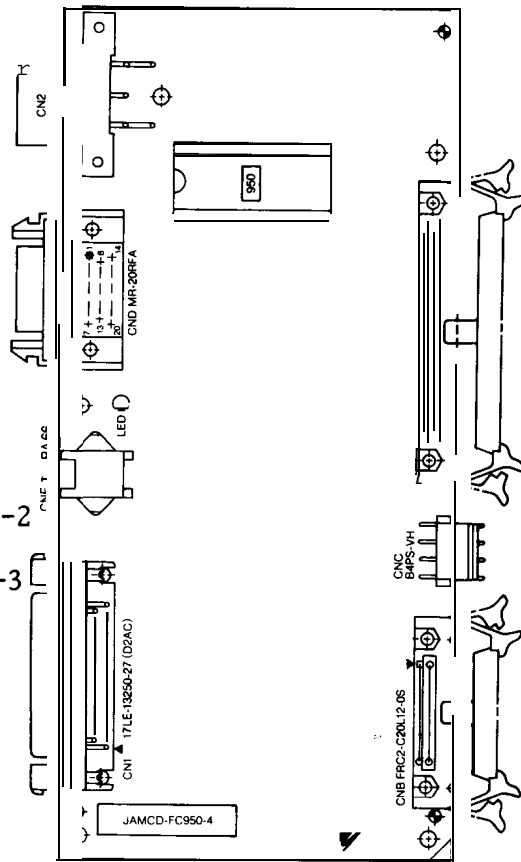

1.2 COMPONENTS (Cent'd)

(12) Combination of Servopack (SC Type) and Motor

Table 1.12 Combination of Servopack (SC Type) and Motor

Motor Model		SERVOPACK CACR-IR					
		05SC	10SC	15SC	20SC	30SC	44SC
M Series	USA ME D-03BS	o					
	USA ME D-06BS		0	0			
	USA ME D-09BS		0	0			
	USA ME D-12BS			○	○		
	USA ME D-20BS			○	○	○	
	USA MED-30BS					○	○
	USA MED-44BS						○
F Series	USAF ED-02CS	0					
	USAF ED-03CS	0					
	USAF ED-05CS	0	0				
	USAF ED-09CS		0	0			
	USAF ED-12CS			0	0		
	USAF ED-20CS				○	○	
	USAF ED-30CS						
USAF ED-44CS						0	
G Series	USAGE D-02AS	0					
	USAGE D-03AS	0					
	USAGE D-05AS	0	0				
	USAGE D-09AS		0	0			
	USAGE D-12AS			0	0		
	USAGE D-20AS				0	0	
	USAGE D-30AS					0	0
USAGE D-44AS						0	
S Series	USASEM-02AS	0					
	USASEM-03AS	0					
	USASEM-05AS	0	0				
	USASEM-08AS		0	0			
	USASEM-15AS			0	0		
	USASEM-30AS					0	0
D Series	USA DE D-05ES	0	0				
	USA DE D-10ES			0	0		
	USA DE D-15ES				0	0	
	USA DE D-22ES					0	0
	USA DE D-37ES						0
R Series	USA REM-01CS	u					
	USA REM-02CS	○					
	USA REM-03CS	0					
	USA REM-05CS	0	0				
	USA REM-07CS		○	○			

(13) Combination of Servopack (SB Type) and Motor

Table 1.13 Combination of Servopack (SB Type) and Motor

Motor Model		SE RVOPACK CA CR-IR					
		05SB	10SB	15SB	20SB	30SB	44SB
M Series	USA ME D-06BS		○				
	USA ME D-09BS		○				
	USAMED-12BS			○			
	USAMED-20BS				○		
	USA ME D-30BS					○	
	USA ME D-44BS						○
F Series	USAF ED-05CS	○					
	USAF ED-09CS		○				
	USAFED-12CS			○			
	USAFED-20CS				○		
	USA FE D-30CS					○	
	USA FE D-44CS						○
G Series	USA GE D-05AS	○					
	USAGED-09AS		○				
	USAGED-12AS			○			
	USAGED-20AS				○		
	USAGED-30AS					○	
	USAGED-44AS						○
S Series	USA SEM-05AS	○					
	USA SEM-08AS		○				
	USA SEM-15AS						
	USA SEM-30AS						
D Series	USA DE D-05ES	○					
	USA DE D-10ES			○			
	USA DE D-15ES						
	USA DE D-22ES					○	
	USA DE D-37ES						
R Series	USA REM-05CS	○					
	USA REM-07CS		○				

Applicable Encoder Type for Motor Models

Motor Model	Encoder Type		
	15-bit Absolute Encoder	15-bit New-type Incremental Encoder	17-bit Absolute Encoder
M Series	○	○	○
F Series	○	○	
G Series	○	○	
S Series	○	○	
D Series	○	○	
R Series	○		

1.2 COMPONENTS (Cent'd)

.SERVOPACK Model CACR-IR03-20SB

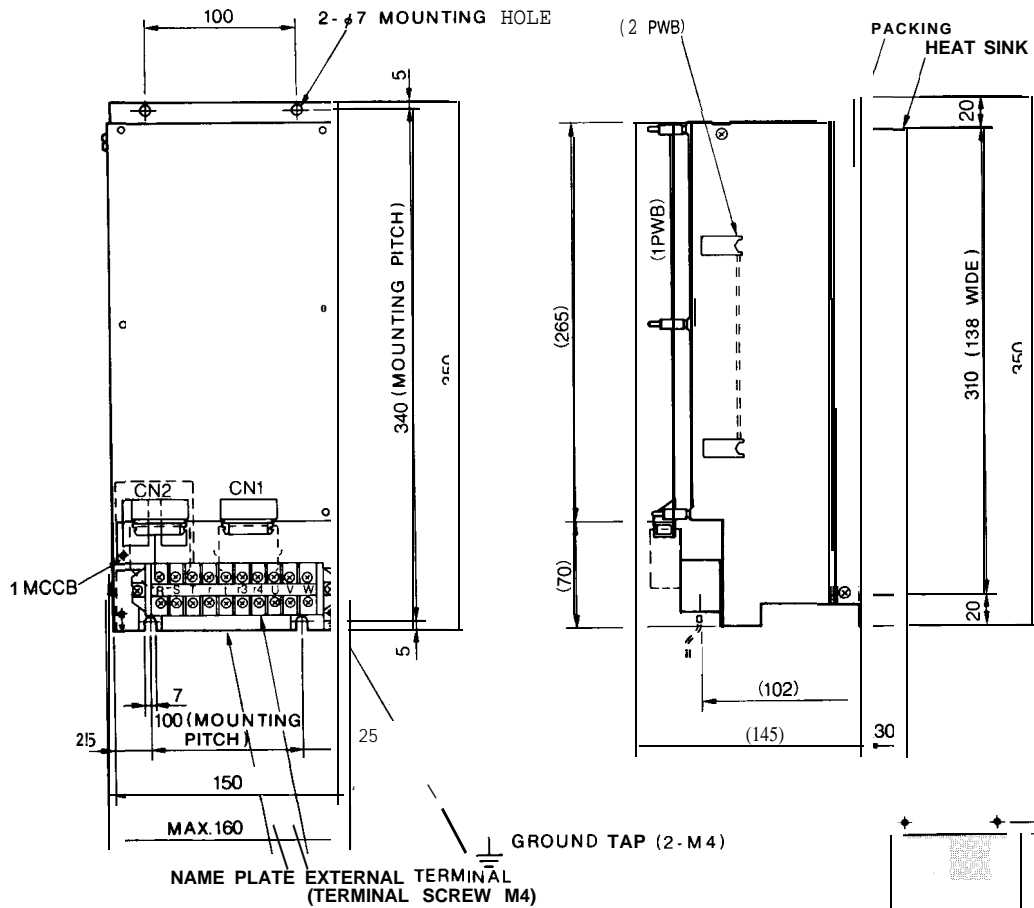

	SE RVOPACK Connector Model	Manufacturer
CN1	MR-20RFA	Honda Communication Industry Co., Ltd.
CN2	MR-20RMA	Honda Communication Industry Co., Ltd.

Approx. mass: 5.5kg

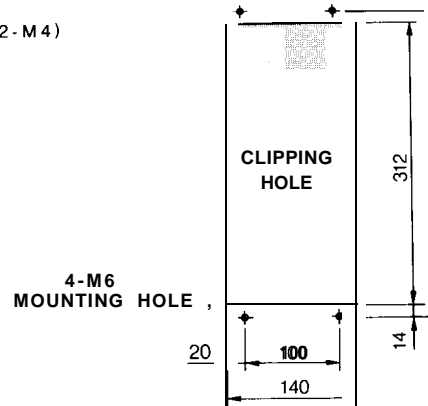

Mounting Hole Processing Diagram

.SERVOPACK Model CACR-IR30SB

1

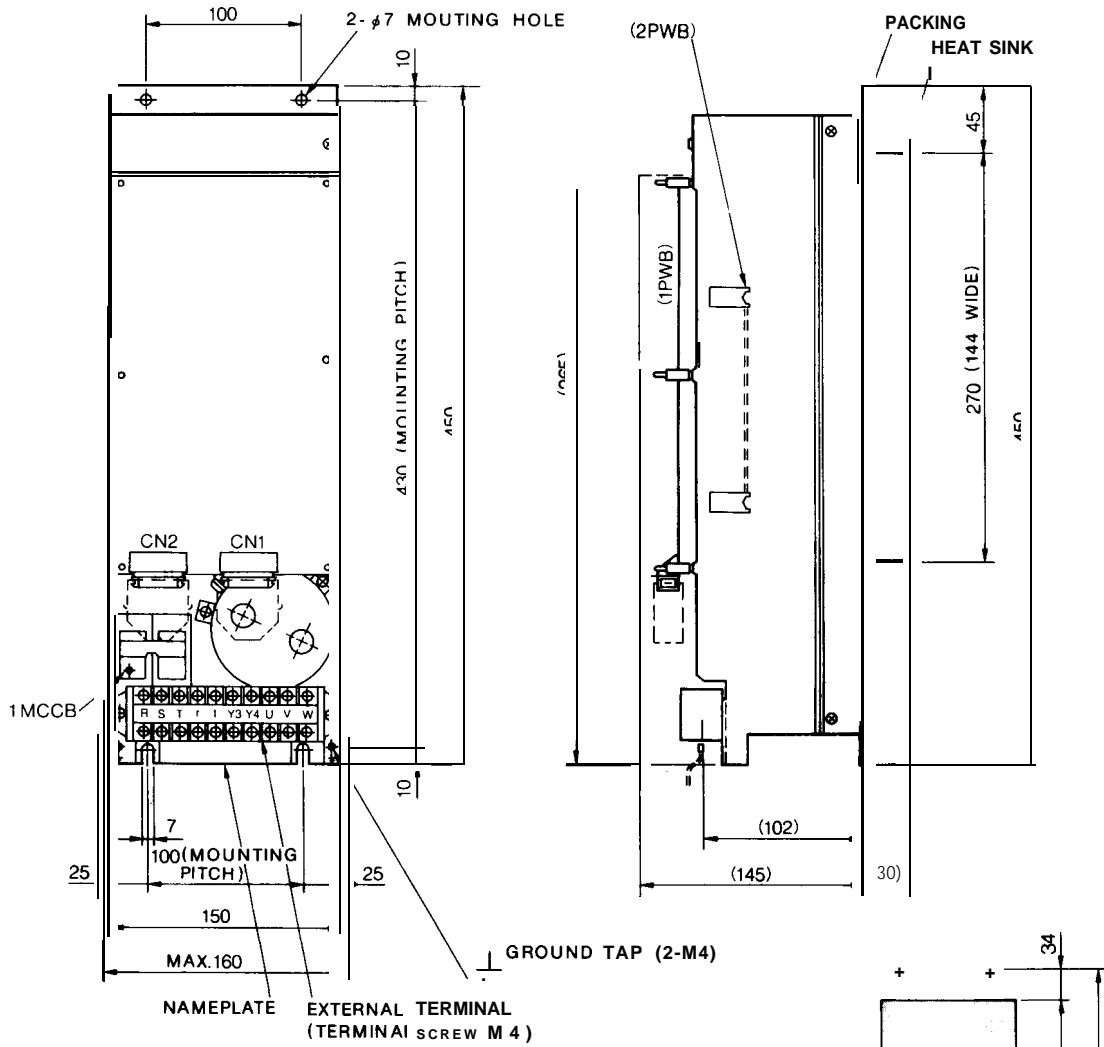

SE RVOPACK Connector Model	Manufacturer
CN1 MR-20RFA	Honda Communication Industry Co., Ltd.
-CN2 MR-20RMA	Honda Communication Industry Co., Ltd.

Approx. mass: 9kg

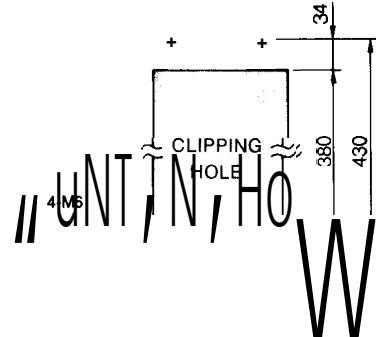

Mounting Hole Processing Diagram

1.2 COMPONENTS (Cent'd)

.SERVOPACK Model CACR-IR44SB

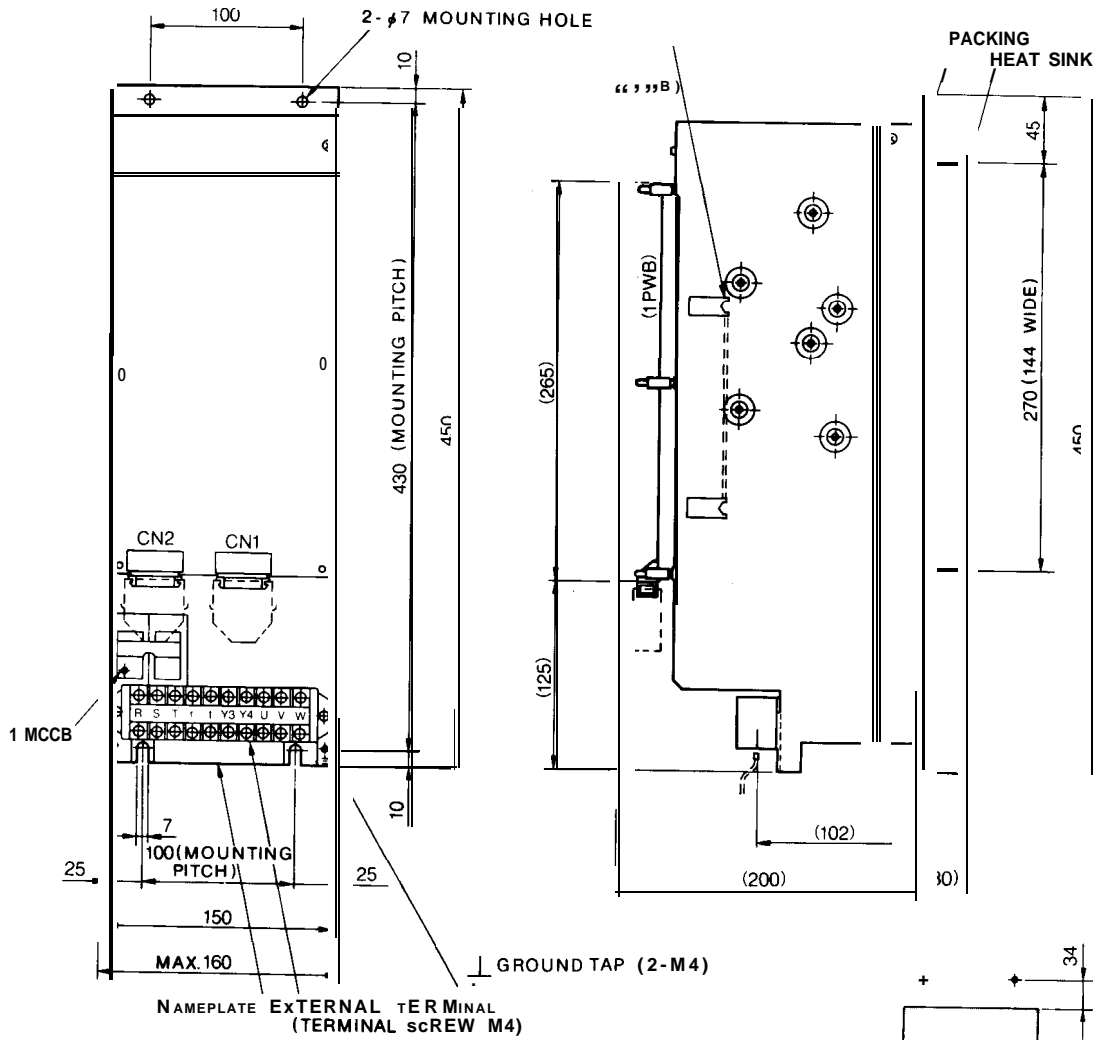

Connector Model	SE RVOPACK	Manufacturer
CN1	MR-20RFA	Honda Communication Industry Co., Ltd.
CN2	MR-20RMA	Honda Communication Industry Co., Ltd.

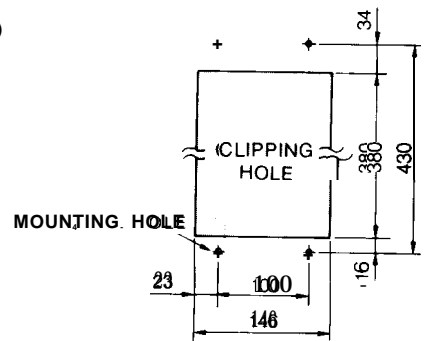

Mounting Hole Processing Diagram

• SERVOPACK Model CACR-IR[][]SC

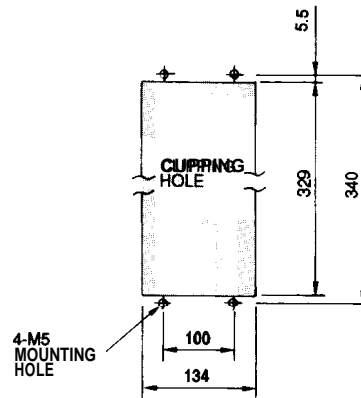
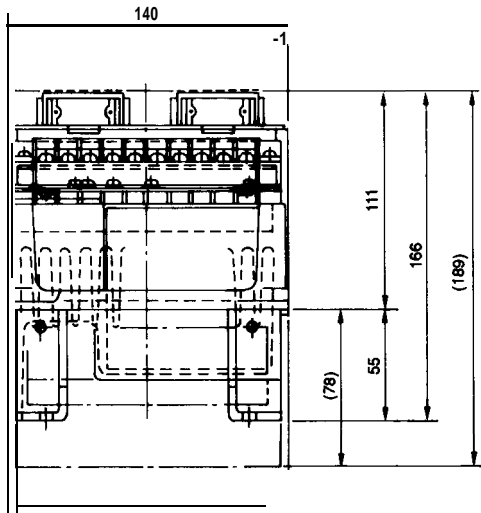
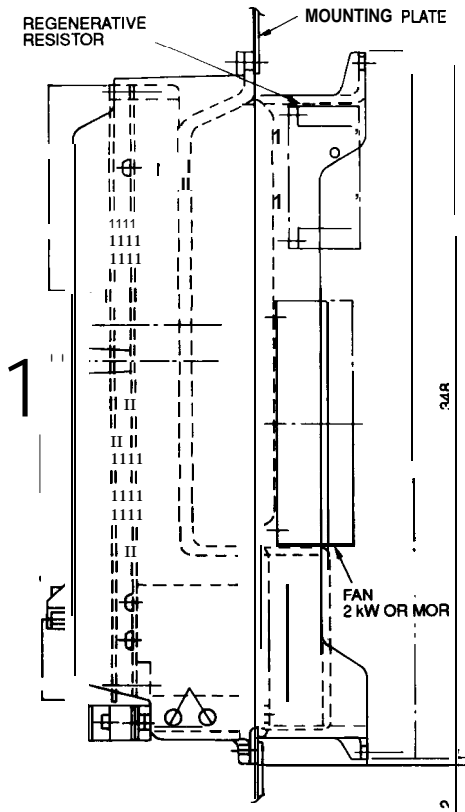
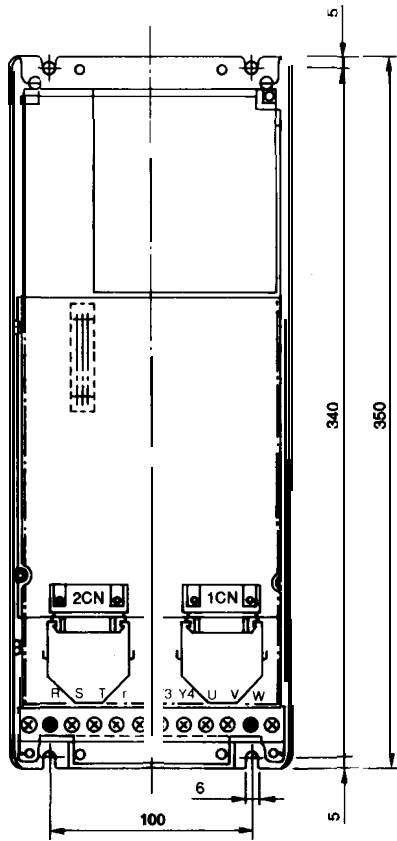

Mounting Hole Processing Diagram

W A

	SE RVOPACK Connector Model	Manufacturer
CN1	MR-20RFA	Honda Communication Industry Co., Ltd.
CN2	MR-20RMA	Honda Communication Industry Co., Ltd.

1.2 COMPONENTS (Cent'd)

(14) Spindle Drive Unit (VS-626MT III)

Table 1.14 Spindle Drive Units

Drive Unit Model	Supply Code	Spindle Motor Specification Model	Remarks
CIMR-MTIII-3.7K	—	UAASKA-04CA1 UAASKA-04CA3	Flanged end Foot-mounted type
CIMR-MT III -5.5K	—	UAASKA-06CA1 UAASKA-06CA3	Flanged end Foot-mounted type
CIMR-MT III -7.5K	—	UAASKA-08CA1 UAASKA-08CA3	Flanged end Foot-mounted type
CIMR-MT III -11K	—	UAASKA-11CA1 UAASKA-11CA3	Flanged end Foot-mounted type
CIMR-MT III -15K	—	UAASKA-15CA1 UAASKA-15CA3	Flanged end Foot-mounted type

**.Models CIMR-MTIII-3.7K,
-5.5K, -7.5K**

**.Models CIMR-MTIII-11 K,
-15K**

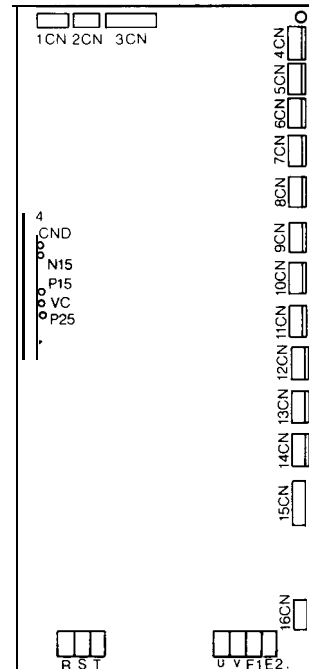
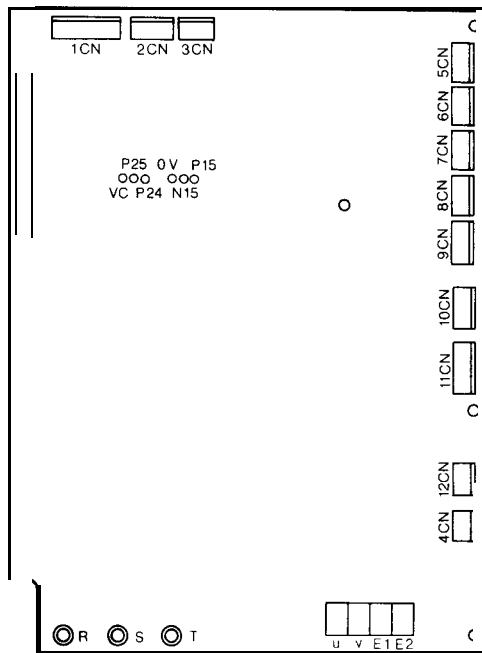

(15) Spindle Drive Unit (VS-626VM3)

Table 1.15 Spindle Drive Units

Drive Unit Model	Supply Code	Spindle Motor Specification Model	Remarks
CIMR-VMS23P7	—	UAASKA-04CZ1 UAASKA-06CZ3	Flanged end Foot-mounted type
CIMR-VMS25P5	—	UAASKA-06CZ1 UAASKA-06CZ3	Flanged end Foot-mounted type
CIMR-VMS27P5	—	UAASKA-08CZ1 UAASKA-08CZ3	Flanged end Foot-mounted type
CIMR-VMS2011	—	UAASKA-11CZ1 UAASKA-11CZ3	Flanged end Foot-mounted type
CIMR-VMS2015	—	UAASKA-15CZ1 UAASKA-15CZ3	Flanged end Foot-mounted type
CIMR-VMS2018	—	UAASKA-19CZ1 UAASKA-19CZ3	Flanged end Foot-mounted type
CIMR-VMS2022	—	UAASKA-22CZ1 UAASKA-22CZ3	Flanged end Foot-mounted type
CIMR-VMS2030	—	UAASKJ-30CZ1 UAASKJ-30CZ3	Flanged end Foot-mounted type

• In-panel Mounted Type

• Heat Sink External Cooling Type

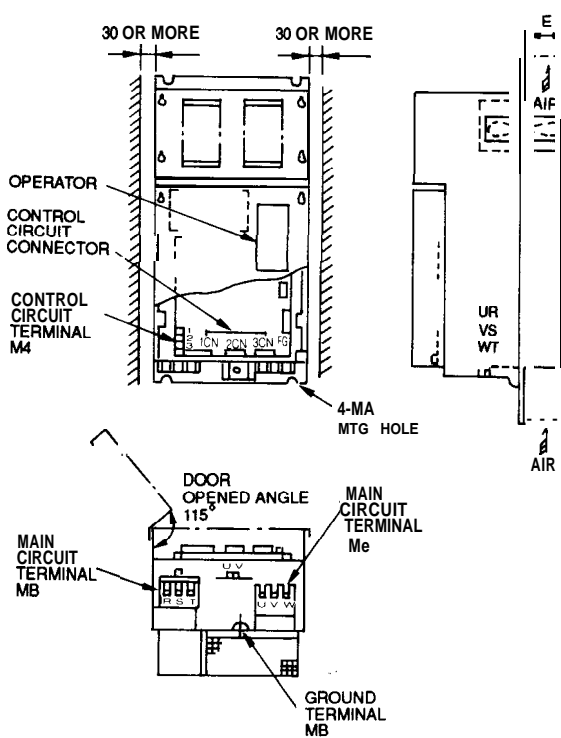
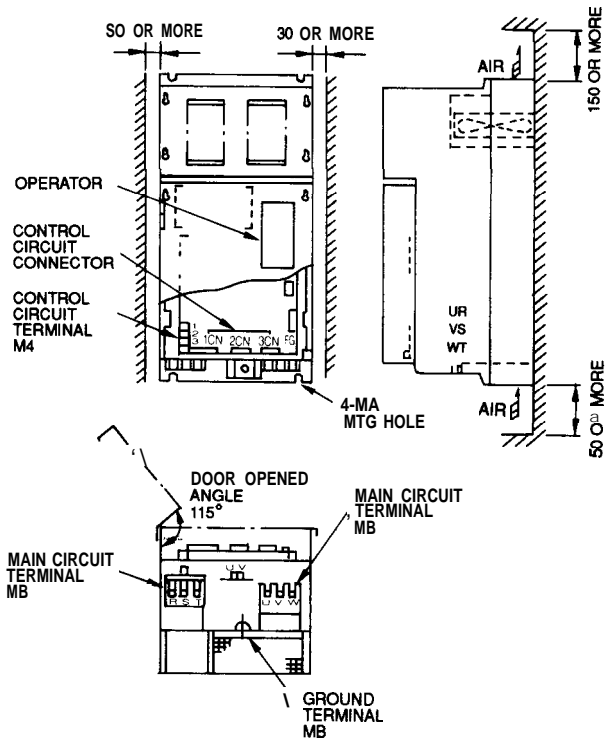

1.2 COMPONENTS (Cent'd)

(16) Maintenance Unit

Table 1.16 Maintenance Unit

Model	Supply Code	Abbreviation	Remarks
JZNC-IDU03	DUN20560	ISD	Sequence ladder editing unit
JZNC-IDU04	DUN20290	FDC	FDD unit for developing ACGC
JZNC-IDU05	DUN20770	AXIM	Monitor board for software support

2. ROUTINE INSPECTION SCHEDULE

This section explains the requirements to be observed for maintenance time in order to keep the equipment in optimum operating condition for an extended period.

2

CONTENTS

2. ROUTINE INSPECTION SCHEDULE	5	7
2.1 ROUTINE INSPECTION	5	8
2.2 TAPE READER MAINTENANCE	59	
2.3 CONTROL PANEL	60	
2.4 ACSERVOMOTOR	6	2
2.5 BATTERY	63	

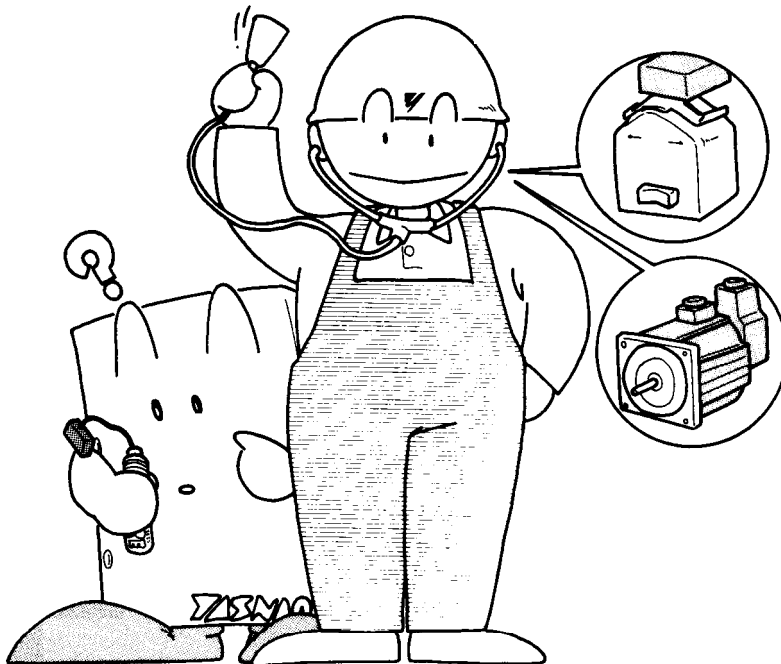

2.1 ROUTINE INSPECTION

Table 2.1 shows items that should be inspected routinely.

Table 2.1 Routine Inspection

Section	Check Item	Frequency	With the System-off	With the System-on	Remarks
Tape Reader	Cleaning of Reading Head	As required	○		Including light source
	Cleaning of Tape Tumble Box	As required	○		
	Lubricating of Tension Arm Shaft End	As required	○		
Control Panel	Doors Tightly Closed	Daily	○		
	Checking for Loose Fit and Gaps in Side Plates and Worn Door Gaskets	Monthly	○		
AC Servo-motor	Vibration and Noise	Daily		○	Feel by hand, and perform an audible inspection
	Motor Contamination and Breakage	Daily or as required	○	○	Visual inspection
Battery		At power on	○	○	Check if alarm for BATTERY is displayed on CRT screen.

Except for those checks which can be made with the NC in the energized state, such as checks for external cleanliness, vibration, and noise, be sure to turn off the power supply to the NC before starting to undertake routine maintenance service.

To turn power OFF to the NC completely, set MCCB (Molded Case Circuit Breaker) on the power panel at the machine to the OFF position .

**Completely
Turned OFF?**

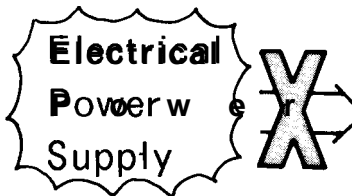

Note

Turning OFF the power supply by depressing the 'POWER OFF' button on the NC control panel is not sufficient, because several areas in the housing are still energized, and are potentially dangerous.

2.2 TAPE READER MAINTENANCE

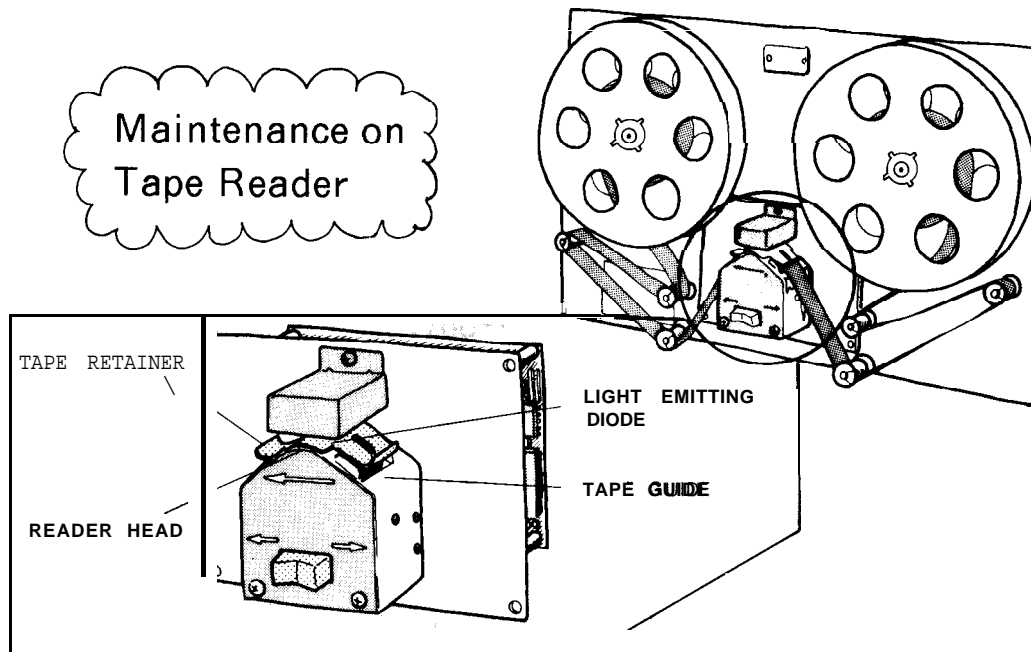

2

(1) Cleaning the Tape Reader Head (as required)

- (a) Remove tape contamination and dust from the glass with a blower brush. If the glass is stained with oil or oily dust, wipe it using gauze or a soft cloth with absolute alcohol. Also clean the tape guide and the tape retainer.
- (b) Remove the dust, if any on top of LED (light source) with a blower brush.

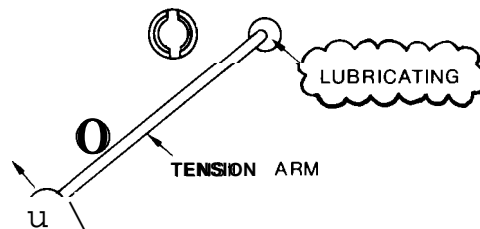

(2) Lubricating of Tension Arm Shaft (as Required)

For the control with 6-inch or 8-inch diameter reels, lubricate the shaft end of tension arm, when the tension arm does not move smoothly.

Note When trouble occurs in feeding or winding tape with 8-inch diameter reels, open the front door and brush away dust around the photo-coupler using a blower brush.

Fig.2.1 8-inch Tape Reel

2.3 CONTROL PANEL

This section explains YASKAWA's standard cabinet. For cabinets customized for customers, refer to the manual issued by machine manufacturer.

(1) Checks for Tight Closing of Doors (daily)

- (a) The control panel is constructed as a dust-proof, sheet-steel enclosure with gasketed doors so as to keep out dust and oil mists. Keep each door tightly closed at all times.
- (b) After inspecting the control with the door open, close the door and fasten door locks (two per door) securely using the key provided (No. YE001). When opening or closing, insert the key all the way into the keyhole and turn until it clicks (approximately a quarter-turn). The key can be removed from an open or closed position.

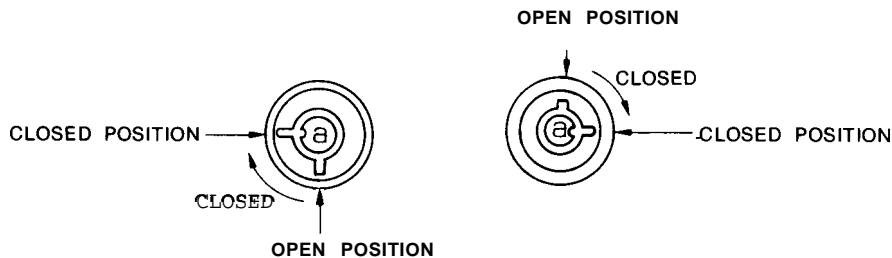
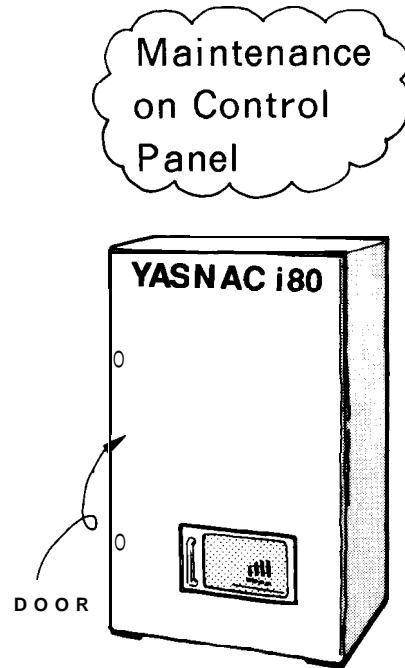

Left - Hand Hinged Door

Right-Hand Hinged Door

Movable part "a" is notched horizontally, Closed

Movable part "a" is notched vertically, Open

Note

If the optional door interlocking switch is provided, opening the door shuts off the main power supply and stops all operations.

Fig. 2.2 Door Lock

(2) Checking for Opening and Damage (monthly)

- (a) Check gaskets on the rims of front and rear doors.

Is the packing damaged?

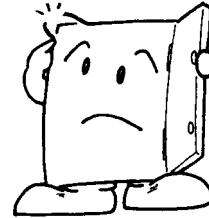

2

- (b) Check if the inside of enclosure is dusty. Clean it, if necessary.

Dusty ?

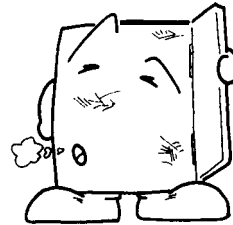

- (c) Check for any opening in the door base with the doors shut tightly.

Is any opening found?

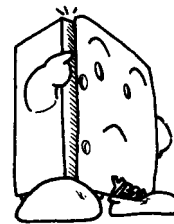

Constant execution of the maintenance work described above will keep YASNAC i80 in optimum condition for an extended period.

2.4 AC SERVOMOTOR

Checking AC SERVOMOTOR

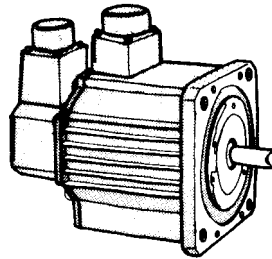

(1) **Vibration and Noise** (daily or as required)

Vibration can be checked by resting the hand on the motor, and for noise, using a listening stick is recommended. If any abnormality is found, contact maintenance personnel immediately.

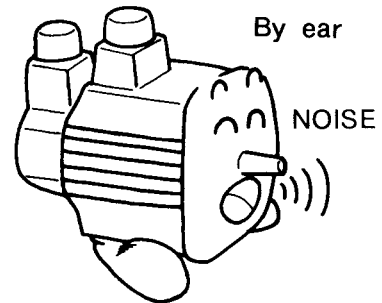
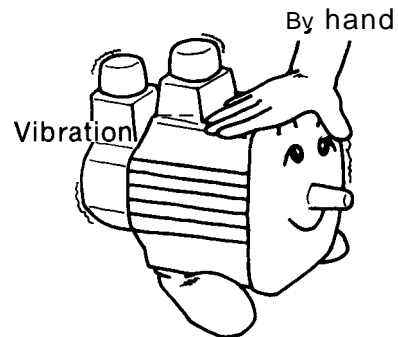

(2) **Motor Contamination and Damage** (daily or as required)

Check the motor exterior visually. If dirt or damage should be observed, inspect the motor by removing the machine cover. Refer to the machine manufacturer's manual.

Checking visually for contamination and damage

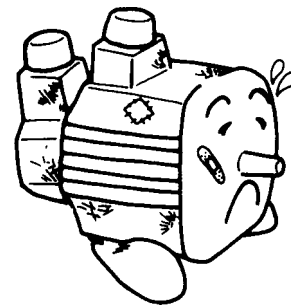

2.5 BATTERY

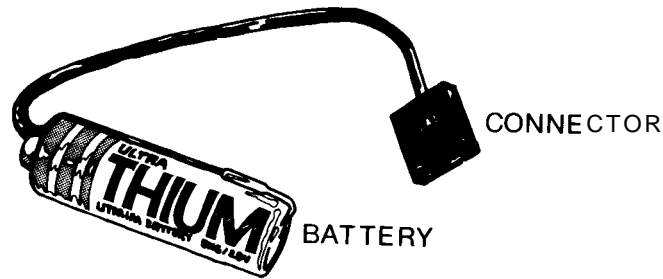

2

Make sure that "BAT" is not displayed on the lower right portion of the CRT screen at power ON. If it is displayed, the battery must be replaced within a month.

Note

No commercially available batteries can be used. When replacing the battery, be sure to contact your YASKAWA representative.

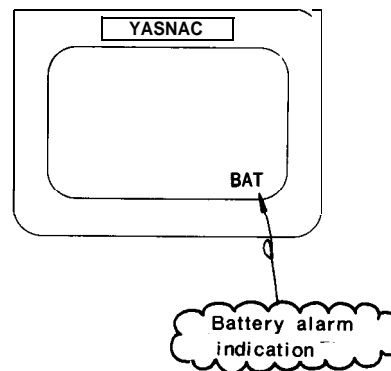

<Replacing Procedure>

- 1 Depress the POWER OFF

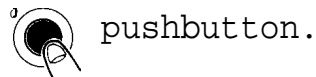

- 2 If a door interlock switch is provided, turn it OFF. The power can be turned ON, with the door open.
- 3 Open the door so that the NC rack (model: JZNC-IRK []) is visible.
- 4 Turn power ON.
- 5 Check if the LED on the model JANCD-FC200, model JANCD-FC300B and model JANCD-FC400 boards goes ON. If the battery must be replaced, the LED goes ON.

2.5 BATTERY (Cent'd)

Fig. 2.3, Fig. 2.4 shows the arrangement of LED and the battery.

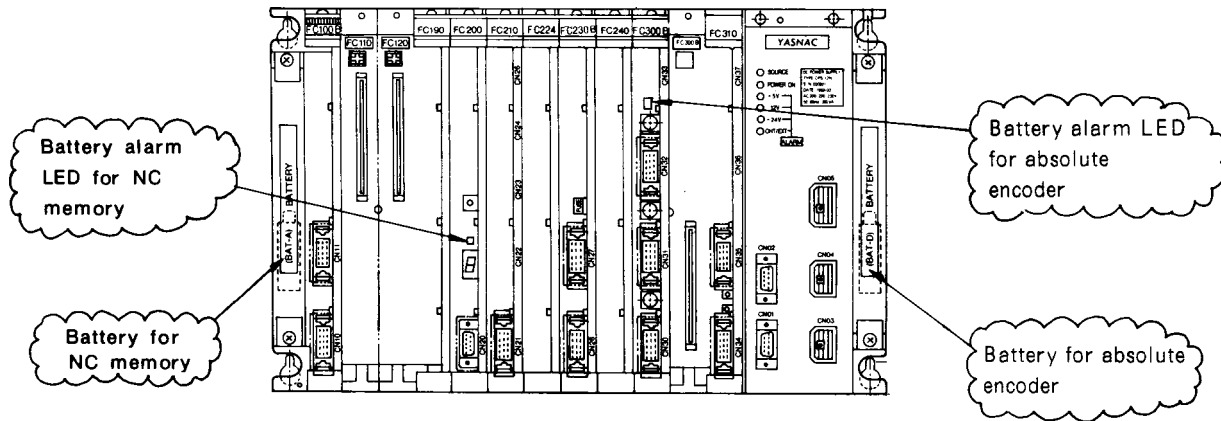

Fig. 2.3 Arrangement of LED and Battery (9" AMGC NC Rack 1)

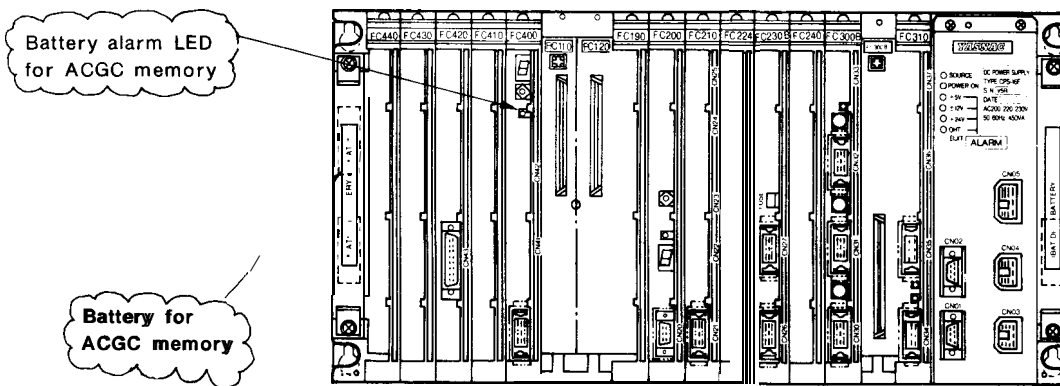

Fig. 2.4 Battery Layout (14" ACGC NC Rack 1)



Three types of batteries are available: for NC memory, for absolute encoder and for ACGC memory.

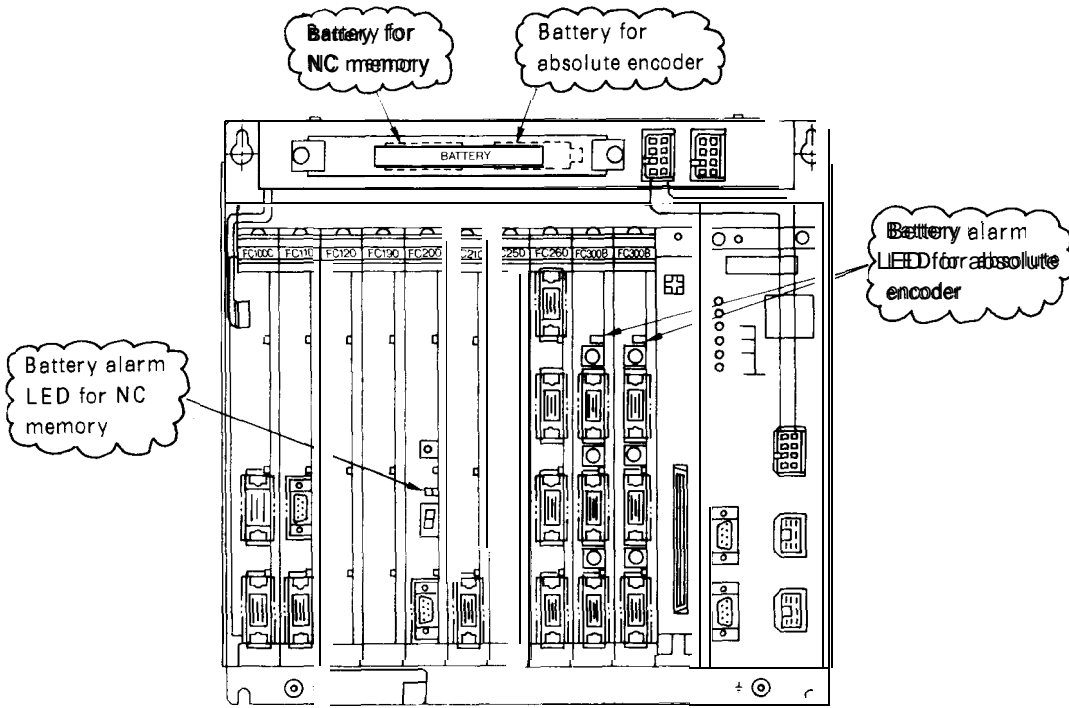

Fig. 2.5 Battery Layout (9" AMGC NC Rack 3)

2

.000 The procedure for checking a defective battery is completed at this point.

Battery model: ER6V3 Supply code BA507

- Turn the power OFF. Use a screwdriver to remove the screws and remove the battery cover. Remove the battery mounted in the holder.
- Put the new battery in the holder and set the connector. The direction of the connector does not matter. Poor connection will not cause conduction. See Fig. 2.6.

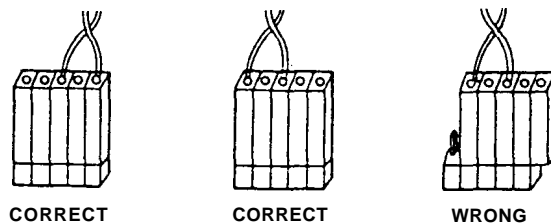

Fig. 2.6 Battery Connection

2.5 BATTERY (Cent'd)

☐ With the power ON, make sure that the blinking display on the CRT screen or the red LED at the front of the model JANCD-FC200, model JANCD-FC300B and model JANCD-FC400 boards goes OFF.



- ① If they are still illuminated, it is due to an improper battery connection or a defective battery.
- ② When any of alarms 2121 and after (encoder battery error) occurs, DGN #35024(*BALM) is not output. When DGN #35024(*BALM) is output, the LED goes on only in the case where the CMOS backup battery is exhausted. This battery differs from the encoder battery.

3. MAINTENANCE INSTRUMENTS

This section describes maintenance instruments.

CONTENTS

3. MAINTENANCE INSTRUMENTS.....67

MAINTENANCE INSTRUMENTS • FROM SOURCE • TO MAINTENANCE

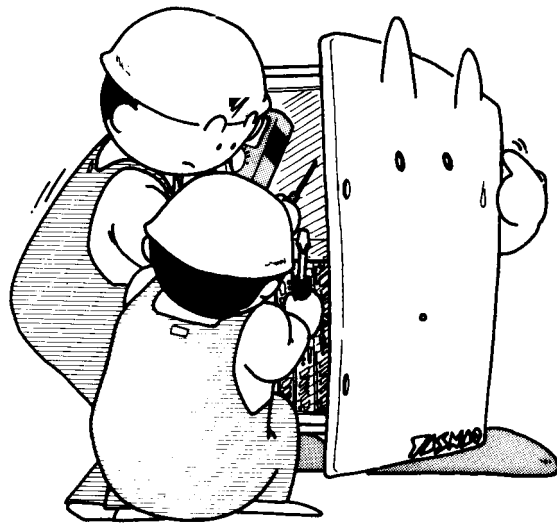

3. MAINTENANCE INSTRUMENTS (Cent'd)

(1) Measuring Instruments

Table 3.1 Measuring Instruments

Name	Allowable Measuring Range	Purpose
Tester or Multi-Purpose Digital Meter	10 to 300 VAC (at 40 to 100 Hz) Tolerance: $\pm 2\%$	To measure AC power voltages
	Several mV to 100 VDC Tolerance: $\pm 2\%$	To measure DC power voltages
	Up to multiples of 10 M Ω Tolerance: $\pm 5\%$	To measure currents, etc.

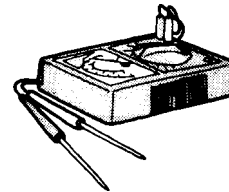

TESTER

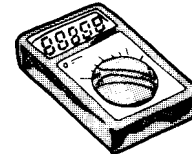

MULTI-PURPOSE DIGITAL METER

(2) Tools

Phillips screwdrivers:
large, medium, and small
Standard screwdrivers:
medium and small
ROM extractor: IC EXTRACTOR
model GX-6

⊕ PHILLIPS SCREWDRIVER

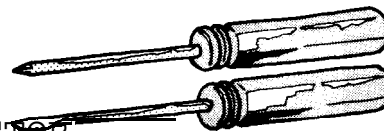

⊖ STANDARD SCREWDRIVER

(3) Chemicals

Cleaning agent for tape reader (absolute alcohol)



(4) Maintenance parts

Fuse model: HM03 0.3 A
Approx. mass: 0.4 g

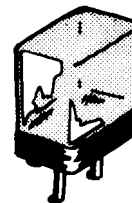

4. TROUBLESHOOTING

This section describes troubleshooting by alarm codes, troubleshooting without alarm codes, supply voltage checks, and status display by the on-line diagnostics function.

The contents of this section should be understood fully to minimize the down time of your system due to malfunctions.

CONTENTS

4. TROUBLESHOOTING	69
4.1 TROUBLE IDENTIFICATION	71
4.1.1 RECOGNITION OF TROUBLE STATUS	71
4.1.2 RECOGNITION OF NC SYSTEM	72
4.2 TROUBLESHOOTING BY ALARM CODES	77
4.2.1 DISPLAY METHOD	77
4.2.2 ALARMS 0010 AND 0011 (PARITY ERROR)	82
4.2.3 ALARMS 0016, 0017, 0018, 9016, 9017 AND 9018 (RS-232C ERROR)	83
4.2.4 ALARM 1099 (TEMPERATURE ALARM INSIDE THE PANEL)	88
4.2.5 ALARMS 2061 TO 2068 (ZERO POINT RETURN AREA ERROR)	89
4.2.6 ALARMS 2071 TO 2078, 2081 TO 2088 (REFERENCE POINT RETURN AREA ERROR)	90
4.2.7 ALARMS 2101 TO 2108 (P-SET ERROR)	91
4.2.8 ALARM 3000 (SERVO UNREADY)	92
4.2.9 ALARM 3001 (CONTROL NOT READY)	92
4.2.10 ALARM 3002 (EMERGENCY STOP)	93
4.2.11 ALARMS 3041 TO 3048 (EXCESSIVE POSITION LAG)	94
4.2.12 ALARMS 3051 TO 3054 (EXCESSIVE POSITION LAG)	95
4.2.13 ALARMS 3061 TO 3068 (MOTOR OVERLOAD)	96
4.2.14 ALARMS 3081 TO 3088 (PG DISCONNECTION ERROR)	96
4.2.15 ALARMS 3091 TO 3094 (SPINDLE PG DISCONNECTION ERROR)	97
4.2.16 ALARMS 3121 TO 3128 (EXCESSIVE SPEED)	97
4.2.17 ALARMS 3141 TO 3148 (PREVENTION OF UNCONTROLLED RUNNING)	98

A
a

CONTENTS

4.2.18 ALARMS 3161 TO 3168 (ABSOLUTE ERRORS).....	98
4.2.19 ALARMS 3181 TO 3188 (POSITION ERRORS).....	99
4.2.20 ALARMS 3201 TO 3208 (SERVODRIVE UNIT COMMUNICATION ERRORS)	99
4.2.21 ALARMS 3301 TO 3305 (OVERCURRENT).....	100
4.2.22 ALARMS 3311 TO 3315 (MCCB TRIP).....	100
4.2.23 ALARMS 3321 TO 3325 (REGENERATIVE ERROR).....	100
4.2.24 ALARMS 3331 TO 3335 (OVERVOLTAGE)	101
4.2.25 ALARMS 3341 TO 3345 (UNDERVOLTAGE)	101
4.2.26 ALARMS 3351 TO 3355 (HEAT SINK OVERHEAT).....	101
4.2.27 ALARMS 3361 TO 3365 (WIRE BREAK IN CURRENT INSTRUCTION CABLE)	102
4.2.28 ALARMS 3371 TO 3375 (MISSING PHASE)	102
4.3 TROUBLESHOOTING WITHOUT ALARM CODES.....	103
4.3.1 POWER CANNOT BE SUPPLIED.....	103
4.3.2 SOLUTION TO ERRORS DETECTED IN SELF-DIAGNOSIS.....	104
4.3.3 CRT SCREEN DOES NOT DISPLAY.....	113
4.3.4 HANDLE MODE OPERATION FAULTY.....	113
4.3.5 MANUAL JOG MODE OPERATION FAULTY.....	115
4.3.6 MANUAL RAPID MODE OPERATION FAULTY.....	117
4.3.7 MANUAL ZERO RETURN OPERATION FAULTY.....	119
4.3.8 CYCLE START FAILURE.....	120
4.3.9 OPERATION IS NOT AVAILABLE WITH G01, G02, OR G03.....	121
4.3.10 SPINDLE DOES NOT ROTATE.....	122
4.3.11 9" CRT SCREEN IS DARK.....	123
4.3.12 EDIT DOES NOT FUNCTION.....	124
4.3.13 FIN WAIT OCCURS BY SPINDLE RELATED INSTRUCTION.....	125
4.3.14 SKIP FUNCTION (G31) OPERATION FAILURE.....	126
4.3.15 TAPE MODE DOES NOT FUNCTION.....	127
4.4 POWER SUPPLY VOLTAGE CHECK.....	128
4.4.1 CHECK AT POWER SUPPLY VOLTAGE.....	128
4.4.2 INDICATION OF LAMP OF POWER SUPPLY UNIT.....	129
4.4.3 CHECK DC POWER SUPPLY VOLTAGE.....	129
4.5 STATUS DISPLAY BY SELF-DIAGNOSIS FUNCTION (DGN).....	130
4.5.1 OUTLINE OF DISPLAY.....	130
4.5.2 DISPLAYING INPUT/OUTPUT SIGNALS.....	131

4.1 TROUBLE IDENTIFICATION

Try to fully analyze the circumstances in which trouble occurs. This is necessary for identifying the trouble and/or for assisting YASNAC service personnel who may be called in to correct the trouble. Verifying the following points will minimize the down time of your system.

4.1.1 RECOGNITION OF TROUBLE STATUS

- (1) What operation will cause the trouble? (Is other operation performed normally?)
- (2) When does the trouble occur: every time or frequently?
- (3) Was there any external disturbance such as power interruption or lightning when the trouble occurred?

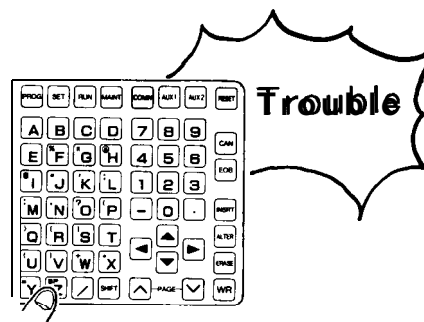

How? How often ?

When?

- (4) Did it occur during or after operation of mode switches such as EDIT or memory, or process keys such as

PROG 'r SET 'r 'oft e y s
on CRT panel?

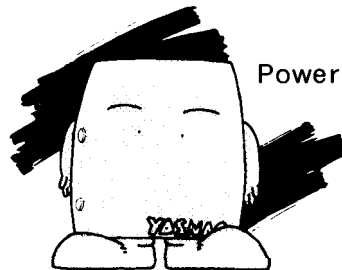

Power loss ?

- (5) Ensure the following points if the trouble occurred as related to feed and/or spindle operation:

- .Check of LED on the drive unit
- .ON/OFF check of circuit breaker
- .Time of trouble occurrence such as
 - at power ON.
 - at acceleration.
 - at deceleration.
 - at steady-state running.

Lightning?

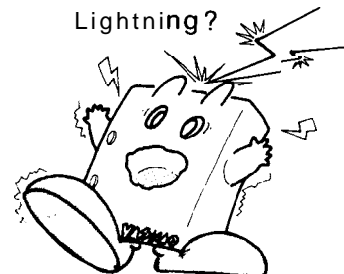

- (6) Does it depend on the part program?

Record the machining program, offset, work coordinate system shift amount or coordinate system set value if it depends on the part program.

4

4.1 TROUBLE IDENTIFICATION (Cent'd)

4.1.2 RECOGNITION OF NC SYSTEM

Ensure the following points so as to correctly recognize the status of the machine and equipment regardless of the details of the trouble.

- (1) Name of machine manufacturer**
- (2) Time of delivery**
- (3) Name and model of machine**
- (4) Name and model of NC unit and others**



The NC unit is provided with an interlock swith. When the operator opens the door, the NC unit power supply is tripped by MCCB and the interlock switch is released. Do not start the check operation until the interlock switch is released.

(Example)

NC unit: YASNAC i80M

Servo drive: CACR-IR05SB

Servo motor: USAGED-05F

Spin dle drive: VS-626 MT III (CIMR-MT III-7. 5K)

Spindle motor: UAASKA-08CA3

(5) NC System Software

YASNAC i80 software is identified by a system number and version number.

(a) **System Number (NC: [][][][][]-[][])**

A system number denotes the number of the system software and consists of five integer digits and a revision number of two digits.

The system number of NC basic software is displayed on the initial screen at power on.

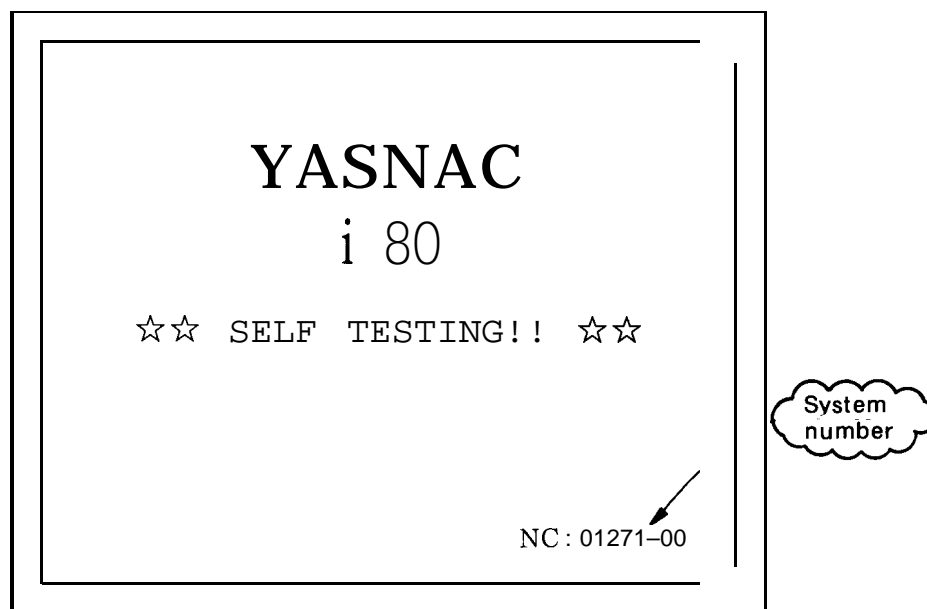

Fig. 4.1 NC Screen at Power on

Optional software is also assigned a system number.

Examples: Communication module
PLC ladder
ACGC application

(b) **Version Number (COM:V[][][].[][][])**

A version number denotes the number of the software of each CPU of the NC basic section, and consists of two integer digits and two fractional digits.

4.1 TROUBLE IDENTIFICATION (Cent'd)

(c) System Consistency

- (i) The function is provided to check whether NC basic software products have version numbers that are consistent with CPUs.
- (ii) For optional software products, only the integer part of the system number is checked for consistency.
If a lack of consistency is found, a serious alarm occurs and the second entry cannot be made.
- (iii) Calling up the system consistency check screen

1 Depress the **MAINT** key.

2 Depress the operation selection key  in function selection mode, and the soft keys shown in the figure will be displayed.

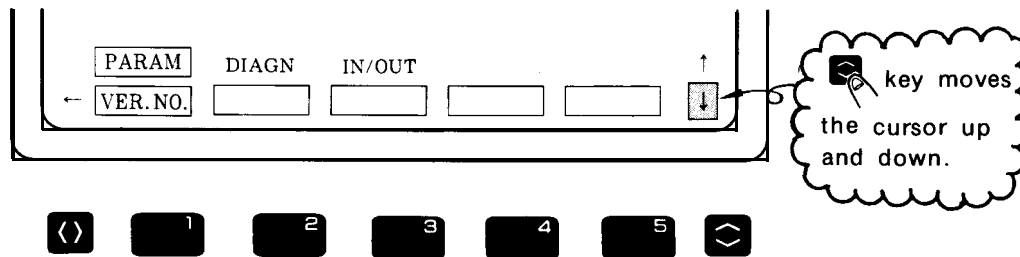

3 Depress **VER.NO.** key.

The screen is displayed as shown in the figure below.

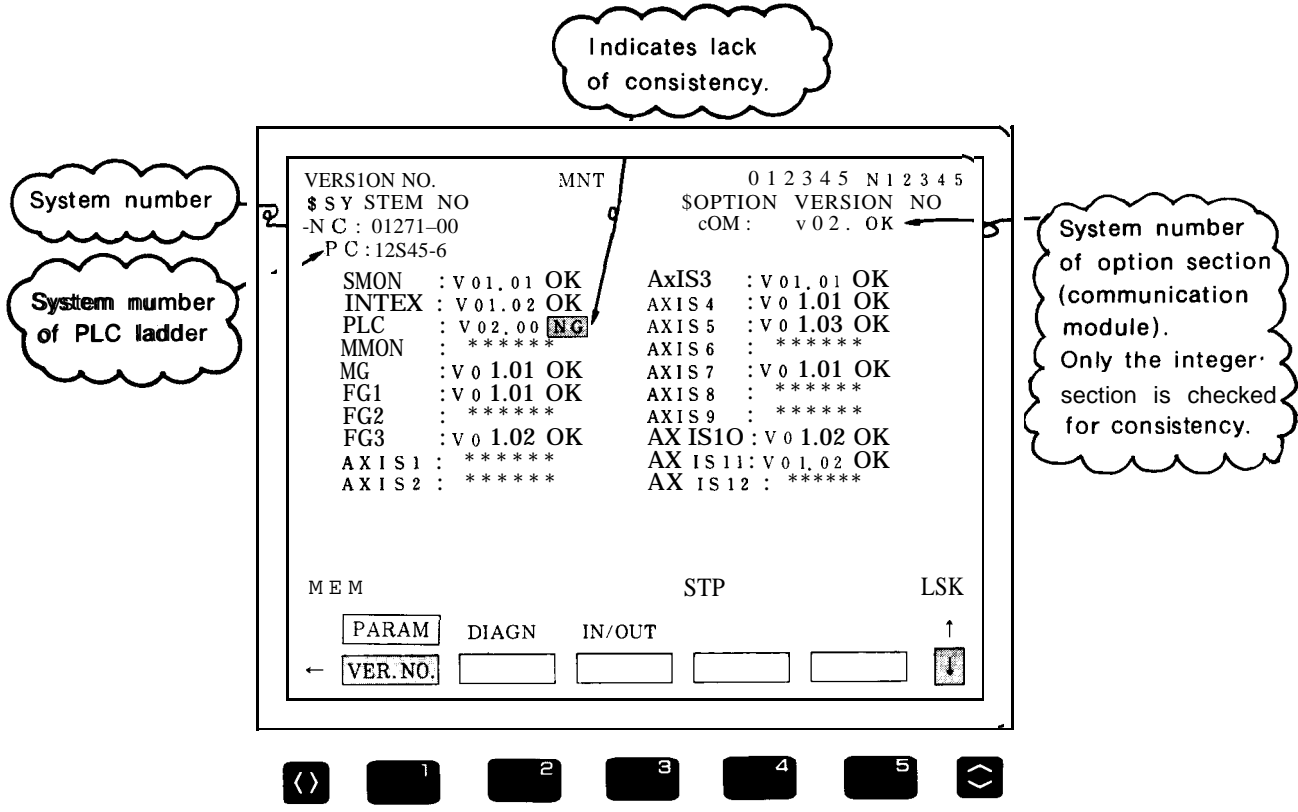

Note The PLC ladder system number is also displayed in kanji characters. NG portion is reversely displayed. A number exceeding 99 is displayed with a question mark (?).

Fig. 4.2 Version Number Display Screen

4.1 TROUBLE IDENTIFICATION (Cent'd)



Only the system number of the NC basic section can be obtained from the screen at power on .

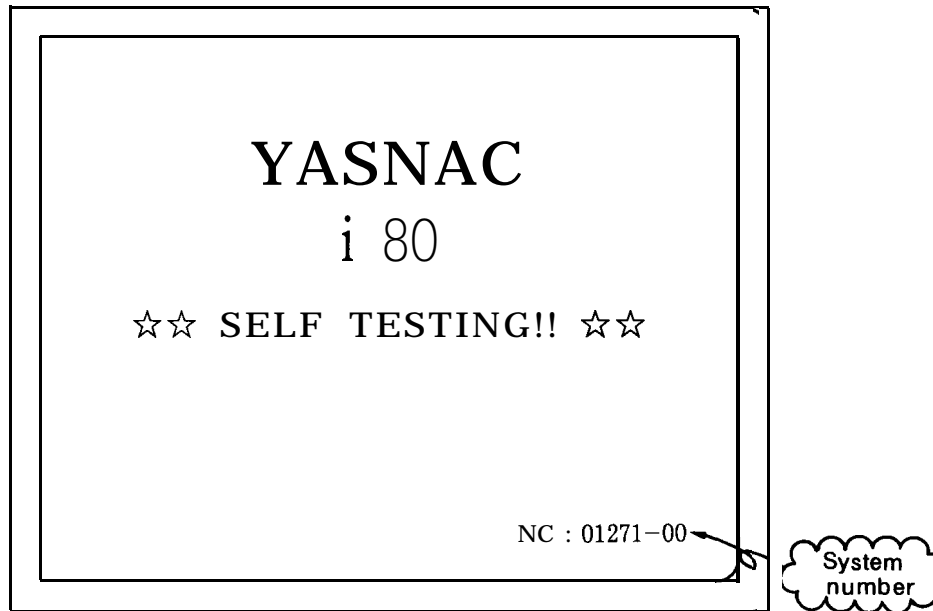

Fig. 4.3 Version Number Display Screen

- (6) As required, check whether parameters match the list supplied with YASNAC i80.

4.2 TROUBLESHOOTING BY ALARM CODES

This description covers the troubles displayed by alarm codes that were recognized by diagnostic function of NC unit during normal operation.

For details, refer to Section 8 of the Appendix "List of Alarm Codes", which is separate from the YASNAC i80M or L instruction manual.

Especially difficult troubles are explained in Section 8 of the Appendix which is separate from this manual.

4.2.1 DISPLAY METHOD

When an alarm occurs, the number of the highest order alarm and a comment are displayed on the stationary display field at the bottom of the CRT screen regardless of the mode and selected screen display. For stationary display, refer to Par. 3.4.1 of the YASNAC i80M or L operation manual. In this case, detailed information of the alarm can be displayed by the following operations:

4

<Operation>

1 Depress the  key.

— The common screen will be displayed.

2 Depress the  job selection soft key.

→ The alarm job is selected. Select alarm function or users function which is displayed on the stationary display field.

4.2 TROUBLESHOOTING BY ALARM CODES (Cent'd)

Table 4.1 Classification by Alarm Number

No.	Explanation	stop	output	Reset, Method, Remarks
#0000 to #0049	Error related to editing and operation, error occurring even in BG	Block stop	Input error, alarm	Reset
#0050 to #0099	Error related to editing and operation, error not occurring in BG	Block stop	Input error, alarm	Reset. Power off in case of #0050 and #0051
#0100 to #0499	Program error	Block stop	Input error, alarm	Reset
#1000 to #1099	Program error, DNC, CMOS total, etc.	Block stop	Input error, alarm	Reset
#2000 to #2199	Machine error, OT, reference point return, machine setup completed, imposition, etc.	Coasting to a stop or immediate stop	Alarm	Reset after removing the cause. In case of "machine setup completed", a reset is automatically made when the power is first turned on.
#3000 to #3299	Servo, spindle related ESP, CPU mutual monitoring	Immediate stop servo off	Alarm	Reset after removing the cause. For SVOFF, a reset is automatically made at SVON.
#8000 to #8049	Memory check error, watchdog timer error, offline error	Immediate stop servo off	Alarm	For maintenance Halt each CPU. Switch to the maintenance screen.
#9000 to #9049	Error occurring during BG operations (basically the same as 0000 to 0049)	Not stopped	BG error output	Soft key reset or reset
No. Missing BAT Indication BAT. AXIS	Battery error Encoder alarm	Not stopped	None	Replace the battery.
No. Missing Warning Message	Wrong key operation, minor editing operation error	Not stopped	Warning	Next key operation

4.2.1.1 ALARM INDICATION JOB **Job Selection Soft key** (**ALARM**)

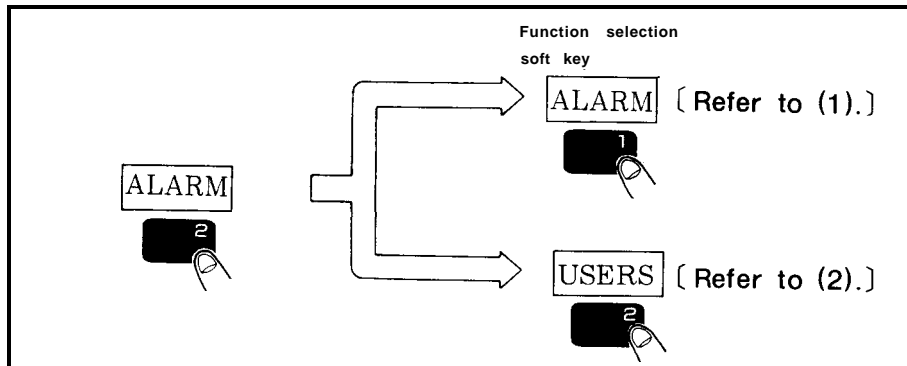

Depressing the job selection soft key **ALARM**

causes either of the following functions to be displayed:

- Alarm function [refer to (1)]
- Users' function [refer to (2)]

A
a

4.2 TROUBLESHOOTING BY ALARM CODES (Cent'd)

(1) Alarm Function



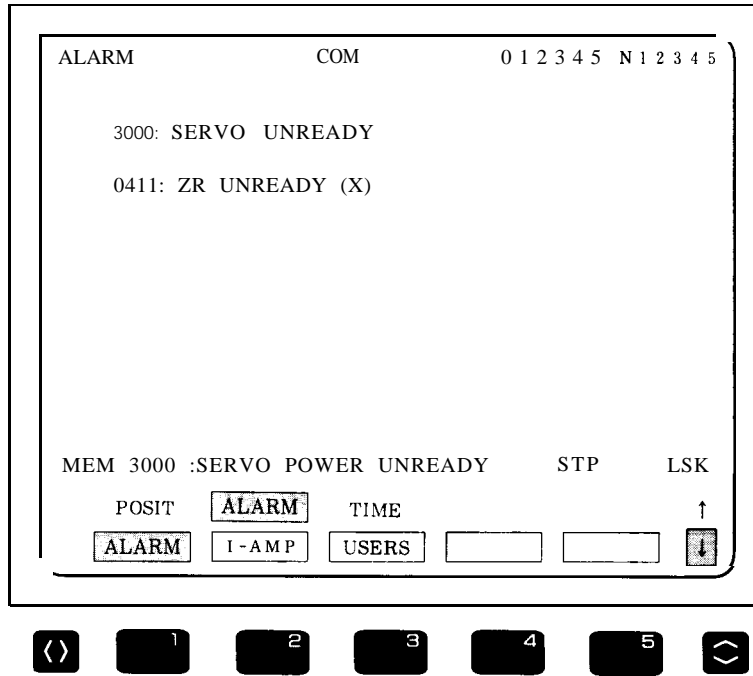

Depressing the  function selection soft key causes all alarms to be displayed.



Note See (2) for the following:
Sequence error O: 1080
1: 2180
2: 3240

Fig. 4.4 Alarm Function Screen

(2) Users' Function

Depressing the  function selection soft key  causes the users' function screen to be displayed. Use  or  key for switching of pages.

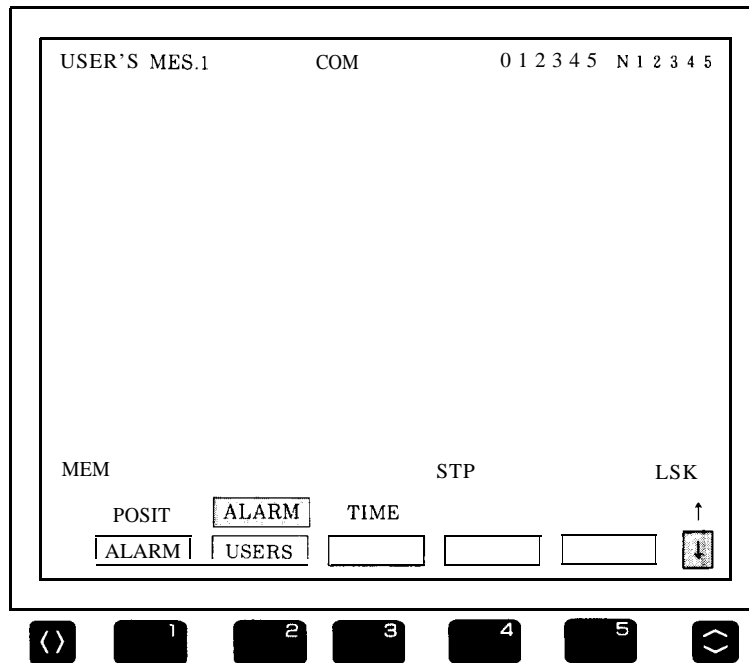

Fig 4.5 Users Function Screen



These troubles are concerned with machine sequence. For details, refer to the manuals prepared by the machine manufacturer.

Eliminate the cause of the alarm and depress the



key, and the alarm state and the alarm display will be reset.

4.2 TROUBLESHOOTING BY ALARM CODES (Cent'd)

4.2.2 ALARMS 0010 AND 0011 (PARITY ERROR)

Table 4.2

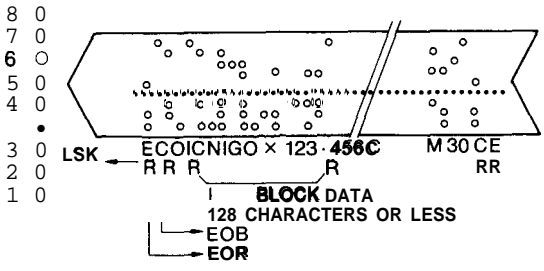
Cause of Trouble	Check Method	Solution
<p>Alarm 0010 (TH Error)</p>	<p>1) In case of tape operation: The number of data holes for each character is checked on the NC tape. An alarm is issued when the number is: Even: For EIA tape Odd: For 1S0 tape (The description that follows applies to the EIA code.)</p>  <p>2) In case of memory operation or at time of EDIT, failure in program area.</p>	<ul style="list-style-type: none"> • Clean tape reader. • Check tape itself if the feed hole is faulty and/or the nap is raised on the hole. • Failure of tape reader itself <p>Failure of JANCD-FC200 board or of expansion memory board (FC120 board)</p>
<p>Alarm 0011 (TV Error)</p>	<p>In case of tape operation: The tape should be capable of TV check. (Number of characters for one block should be even, including EOB.)</p>	<p>If the tape cannot perform TV check, use it by setting $\overline{\text{SET}}_{\text{pm0004 D}_1} = \text{O}$, $\text{pm0002 D}_1 = \text{O}$ (TV check OFF) or make it so that it can perform TV check.</p>

4.2.3 ALARMS 0016,0017,0018,9016, 9017 AND 9018 (RS-232C ERROR)

Cause of Trouble	Check Method	Solution
Alarm 0016 9016 (Communication Error)	Communication error of RS-232C (ex. too rich noise level)	•Check cable grounding.
Alarm 0017 9017 (Overrun)	After RS-232C interface stop code was output, more than 10 characters were read.	
Alarm 0018 9018 (Line Selection)	RS-232C interface line was erroneously selected.	•Check the specifications of RS-232C equipment •Check parameters.

Note 0017 and 9017 are online and offline codes, respectively, For example, online transmission error is indicated by 0017 and offline transmission error is indicated by 9017.

4

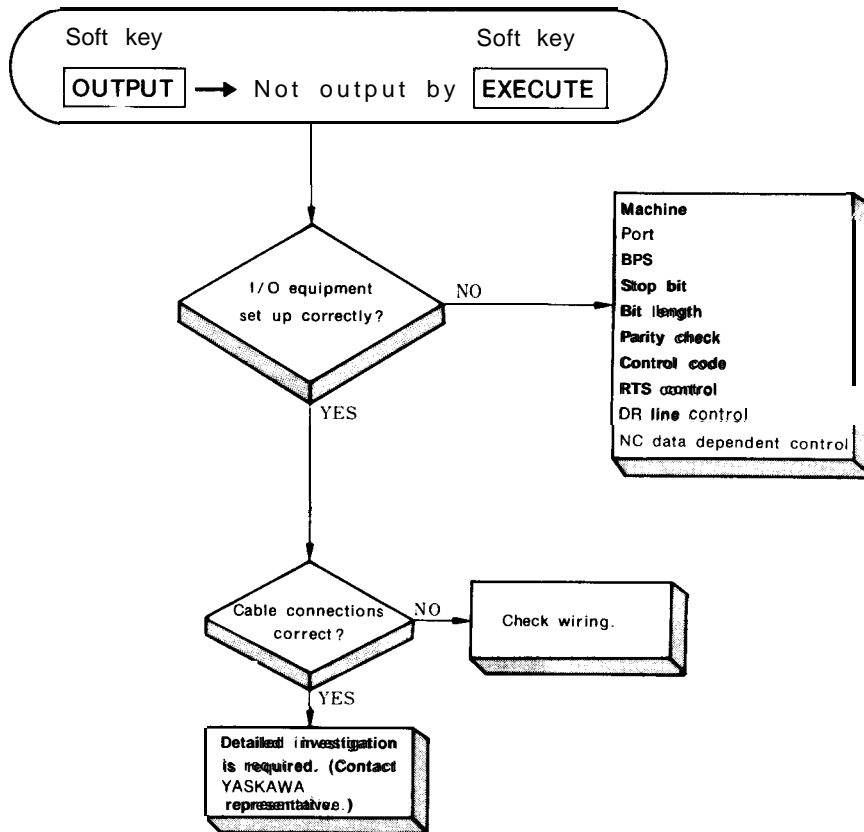



Fig. 4.6 RS-232C Interface Troubleshooting Flowchart

4.2 TROUBLESHOOTING BY ALARM CODES (Cent'd)

.Setting of Applicable Interface

Set the data transmission baud rate, stop bit length, and control code sending command specifications.

<Operation>

☐ Depress the  key.

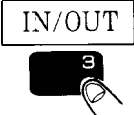
☐ Depress the  job selection soft key.

- The I/O verification job is selected.

☐ Depress the  function soft key.

- Select the I/O equipment setup function.

☐ Set parameters one after another interactively.

I/O UNIT SET	MNT	0 1 2 3 4 5	N 1 2 3 4 5
	IN	OUT	
UNIT	RS-232C	RS-232C	
PORT	No.1	No.2	
BAUD RATE	4800	9600	
STOP BIT	2 BITS	1 BITS	
BITS	8 BITS	7 BITS	
PARITY	OFF	EVEN PARITY	
XON/OFF	ON	OFF	
RTS CNTRL	ON	OFF	
PARITY ISO	ON	OFF	
MEM	STP	LSK	
PARAM	DIAGN	IN/OUT	
← 600	1200	2400	4800 9600 ↑

Fig. 4.7 Setting of Serial Interface

Table 4.3 shows settings of serial interface.

Table 4.3 Settings of Serial Interface

Menu Item	Input	output
UNIT	YE tape reader	YE tape puncher
	General-purpose RS-232C	General-purpose RS-232C
PORT	First	First
	Second	Second
BAUD RATE	75	75
	150	150
	300	300
	600	600
	1200	1200
	2400	2400
	4800	4800
	9600	9600
STOP BIT	1 bit	1 bit
	2 bits	2 bits
BIT LENGTH	7 bits	7 bits
	8 bits	8 bits
PARITY	Even parity	Even parity
	Odd parity	Odd parity
	Without	Without
CONTROL CODE	With	With
	Without	Without
RTS CONTROL	With	With
	Without	Without
PARITY ISO	With	With
	Without	Without

4

Note

The two RS-232C ports cannot be used at the same time.
Set the first and the second ports separately.

..

4.2 TROUBLESHOOTING BY ALARM CODES (Cent'd)

For example, to switch from the first port to second port:

- Put the cursor on the port to switch to.
- Depress the operation selection  .
- 1 Depressing the desired soft key writes data to the cursor position determined above.

Table 4.4 shows RS-232C voltage levels and Table 4.5 shows RS-232C interface connection cables.

Table 4.4 RS-232C Voltage Levels

	$V_0 < -3\text{ V}$	$V_0 < +3\text{ V}$
Function	OFF	ON
Signal Status	Mark	Space
Logic	1	0

Table 4.5 Connection Cable (A) for Terminal Connection RS-232C Interface







NC Side (D B-9P)			Connection	External Equipment
Symbol	Signal	Pin No.		Symbol
FG	Frame Grounding	1		FG
SD	Send Data	2		SD
RD	Receive Data	3		RD
RS	Send Request	4		RS
Cs	Sendable	5		Cs
DR	Data Set Ready	6		DR
SG	Signal Grounding	7		SG
ER	Data Terminal Ready	9		IO BUSY
				ER

Fig. 4.8 shows connection example of standard RS-232C tape reader.

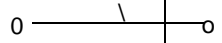

Note

Keep cable length from tape reader to main board (model JANCD-FC200) less than 3m. Contact your YASKAWA representative in advance if it is necessary to exceed 3m.

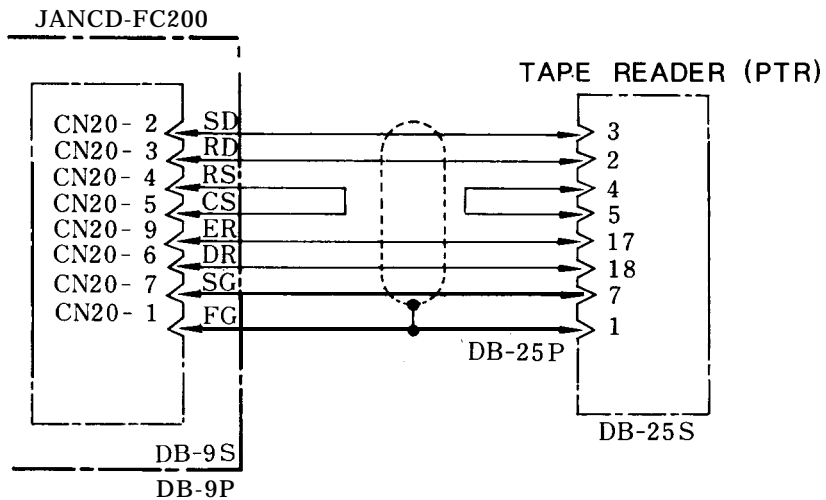
Fig. 4.8 Example of 1st RS-232C Interface

4

4.2 TROUBLESHOOTING BY ALARM CODES (Cent'd)

4.2.4 ALARM 1099 (TEMPERATURE ALARM INSIDE THE PANEL)

Table 4.6

Cause of Trouble	Check Method	Solution
Ambient temperature of NC rack exceeded the specified value (70 °C ± 3 °C) by measuring at top of CPS-12N or CPS-16F as a result of fan failure.	<ul style="list-style-type: none"> • Open NC panel door and ensure that the fan runs normally. • Ensure that air comes out of exhaust port at the cooling duct. • Ensure that air intake port of cooling duct is not blocked. 	<ul style="list-style-type: none"> • Replace the fan if faulty. Call our service personnel Yaskawa representative (YASREP). • If cooling duct is clogged, remove the cause of clogging and restart the operation.
Failure of power supply unit (CPS-12N or CPS-16F) Temperature detector is built inside the power (supply unit.)	<ul style="list-style-type: none"> • Turn OFF power supply, open the door of NC panel and cool it for about 30 min. • If the alarm still lights. 	The power supply unit must be NC placed. Contact Yaskawa representative (Y ASREP).
Ambient temperature of NC panel is too high. (Applicable temperature range is 0 °C to +40 °C.)	<ul style="list-style-type: none"> • Measure the ambient temperature. • The temperature may rise if NC panel is exposed to direct rays of the sun. 	<ul style="list-style-type: none"> • Reduce the effects of temperature rise by shielding the NC unit, etc.

4.2.5 ALARMS 2061 TO 2068 (ZERO POINT RETURN AREA ERROR)

Table 4.7

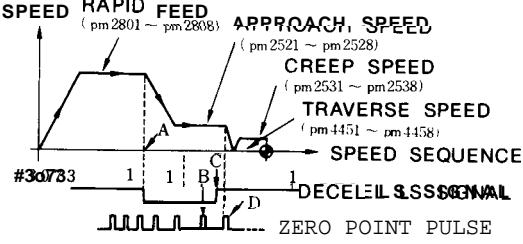
Cause of Trouble	Check Method	Solution
<p>Zero point return start position was at zero point side rather than at deceleration LS side</p>	<p>Try zero point return again while observing the deceleration LS DECLS:</p> <p>DGN #3073 D₀ (1st-axis) #3073 D₁ (2nd-axis) #3073 D₂ (3rd-axis) #3073 D₃ (4th-axis) #3073 D₄ (5th-axis) #3073 D₅ (6th-axis) #3073 D₆ (7th-axis) #3073 D₇ (8th-axis)</p> <p>As shown below an alarm results when zero point return is made between DECLS and zero point. Note that this error check can be performed only after power supply is turned OFF and the manual return to zero point has been completed.</p> 	<p>Return it to the deceleration LS or try the zero point return again from a more distant point.</p>
<p>Final distance of zero point return is too short, or, approach speed is too fast.</p>	<p>Perform the zero point return by jog feed. Try to change parameter for final distance. Compare the parameter for approach speed with parameter list.</p>	<p>Make final distance (parameter) longer:</p> <ul style="list-style-type: none"> • PRM pm4451 to pm4458 • Approach speed: pm2521 to pm2528

4

..

4.2 TROUBLESHOOTING BY ALARM CODES (Cent'd)

4.2.6 ALARMS 2071 TO 2078,2081 TO 2088 (REFERENCE POINT RETURN AREA ERROR)

Table 4.8

Cause of Trouble	Check Method	Solution
<p>This type of alarm results when reference point return performed manually. It also occurs by reference point return at low speed due to DECLS chattering. Occurs at high speed by error or reference point pulse.</p>	<p>Observe DECLS chattering: [I/O Signal #3073 D₀(1st-axis) #3073 D₁ (2nd-axis) #3073 D₂ (3rd-axis) #3073 D₃ (4th-axis) #3073 D₄ (5th-axis) #3073 D₅ (6th-axis) #3073 D₆ (7th-axis) #3073 D₇ (8th-axis)</p> <p>Observe reference point pulse: [I/O Signal In case of i80M #3610 D₆(1st-axis) #3611 D₆ (2nd-axis) #3612 D₆ (3rd-axis) #3613 D₆ (4th-axis) #3614 D₆ (5th-axis) In case of i80L #3620 D₂(1st-axis) #3621 D₂ (2nd-axis) #3622 D₂ (3rd-axis) #3623 D₂ (4th-axis) to to #3627 D₂ (8th-axis)</p>	<p>Adjustment of replacement of LS • Failure of module JANCD-FC800 Replace AC servo drive. Replace FC300B board. Replace AC motor. Replace PG cable.</p>
<p>The alarm occurs at automatic reference point return.</p>	<p>In case of G28 : Same as above</p>	<p>Same as above</p>
	<p>In case of G27 : Programmed position differs from reference point.</p>	<p>Check the program.</p>

4.2.7 ALARMS 2101 TO 2108 (P-SET ERROR)

P-Set Error results when difference between command position and machine position does not fall within parameters pml321 (1st-axis) to pml328 (8th-axis) at the time of completing positioning with G00, G27, G28, G29 and G30.

Check is also required at the time of ERROR DETECT ON (Input signal 3004 D₄ = 1, In i80L multi-program system, #3054 D₄ = 1 for the second program, #3064 D₄ = 1 for the third program) and G04 (dwell).

Table 4.9

Cause of Trouble	Check Method	Solution
Machine runs too heavy.	Observe reference torque by using monitor board.	Lighten machine load.
Servo error pulse exceeds setting range.	Check error pulse in the error pulse display.	FC300B or AC servo drive unit may be defective. Contact your YASKAWA representative.

4

4.2 TROUBLESHOOTING BY ALARM CODES (Cent'd)

4.2.8 ALARM 3000 (SERVO UNREADY)

Table 4.10

Cause of Trouble	Check Method	Solution
Secondary power supply is not applied.	This is a normal result when depressing NC RESET after primary power application, or resetting emergency stop alarm, " etc.	Depress POWER ON button again.
In case of automatic servo power application I/O input specification is not activated by secondary power supply.	Ensure that it is set to I/O Signal #3005 D ₀ = 1 (SVON) #3503 D ₀ = 1 (SVONS)	Check wiring and sequence.
Emergency stop input.	Check if ALM3002 displays, or #3503 D ₄ = 1.	Reset emergency stop input.
Secondary power supply was tripped by other alarm.	Check for other alarm display.	Take corrective action according to alarm code.

4.2.9 ALARM 3001 (CONTROL NOT READY)

This type of alarm results when position lag exceeds the range of pml321 (1st-axis) to pml328 (8th-axis) after power application and self-diagnosis.

Table 4.11

Cause of Trouble	Check Method	Solution
Machine is running	Select ERROR PULSE display screen from common process current value display and read the values of X-, Y-, Z-, 4th and 5th. axis.	This is a problem of the machine side rather than failure of NC unit. Contact machine manufacturer.
PG signal keeps feeding.		Replace PG or servo. Contact your YASKAWA representative.
FC300B _{failure}		Replace FC300B. Contact your YASKAWA representative.

4.2.10 ALARM 3002 (EMERGENCY STOP)

Table 4.12

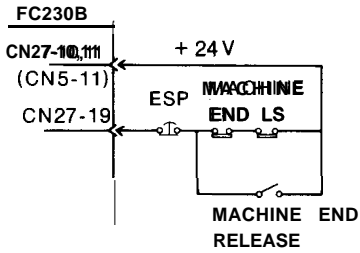
Cause of Trouble	Check Method	Solution
<p>Emergency stop button depressed, or, machine end LS is out of place.</p>	<p>After ensuring I/O signal #3500 D₂ = 0 (during emergency stop), check continuity of emergency stop button or machine end LS shown below. For correct connection, refer to connection diagram prepared by machine manufacturer.</p>  <p>The diagram shows a circuit where +24V power is connected to terminal CN27-10,111 (CN5-11) of the FC230B module. This power line passes through an Emergency Stop Pushbutton (ESP) and a normally closed contact labeled MACHINE END LS. The circuit then branches to terminal CN27-19 of the FC230B module and a normally open contact labeled MACHINE END RELEASE. The return path for the power is connected to the common terminal of the MACHINE END LS and MACHINE END RELEASE contacts.</p>	<p>Reset the emergency stop button. Release it from machine end LS according to instruction manual prepared by machine tool manufacturer.</p>
<p>Failure of FC230B or FC260</p>	<p>This FC230 failure if alarm 3002 lights even at #3500 D₂ = 1</p>	<p>Replace FC230B or FC260. Contact your YASKAWA representative.</p>
<p>Drop of +24 V power voltage</p>	<p>Check +24 VDC power. If the voltage is below +20 V, it indicates possible trouble.</p>	<p>Replace CPS-12N or CPS-16F (power supply unit). Contact your YASKAWA representative.</p>

4

4.2 TROUBLESHOOTING BY ALARM CODES (Cent'd)

4.2.11 ALARMS 3041 TO 3048 (EXCESSIVE POSITION LAG)

Excessive position lag results when the lag of machine to command value exceeds 120% at 100% rapid traverse rate.

Table 4.13

Cause of Trouble	Check Method	Solution
<p>Motor load is too large and movement command is too small. e.g.</p> <ul style="list-style-type: none"> •Excessive drilling load •Machine requires lubricant. •Program error causes tool/work contact. 	<ul style="list-style-type: none"> •Observe motor current or torque monitor if alarm occurs during idle running \oplus/\ominus direction at jog or rapid mode after turning ON the power. •Check oil film on slide surface of machine and check oil level in tank. 	<p>Restart operation if machine remove the trouble.</p>
<p>Torque is not applied.</p>	<ul style="list-style-type: none"> •Check torque limit parameters (pm1671 to pm1678, pm1681 to pm1688) signal. •Check torque reference on monitor board. 	<ul style="list-style-type: none"> •Correct torque limitation. •Replace AC SERVOPACK. •Replace the motor
<p>Wiring failure</p>	<p>Check wiring. Refer to Connecting Manual (T0E-C843-11.5).</p>	<p>Refer to Connecting Manual Par. 11. Connection of Feed Servo Unit.</p>
<p>The movement distance per motor rotation is specified incorrectly.</p>	<p>Feed at low speed such as in handle mode, etc. It will be normal if the actual movement distance equals the position display change distance.</p>	<p>Determine correct movement distance (pm1821 to pm1828) per motor rotation from gear ratio and ball-type screw pitch.</p>

Spindle alarms

4.2.12 ALARMS 3051 TO 3054 (EXCESSIVE POSITION LAG)

Excessive position lag results when the lag of machine to command value exceeds parameter pm1351 to pm3054.

Table 4.14 Alarms 3051 to 3054 (Excessive Position Lag : spindle)

Cause of Trouble	Check Method	Solution
Motor load is too large and movement command is too small. e.g. •Excessive drilling load •Machine requires lubricant. •Program error causes tool/work contact.	<ul style="list-style-type: none"> Observe motor current or torque monitor if an alarm occurs during idle running ⊕/⊖ direction (forward/reverse) at log or rapid mode after turning ON the power. Check oil film on slide surface of machine and check oil level in tank. 	If the cause is in the machine, correct the trouble and restart operation.
Torque is not applied.	<ul style="list-style-type: none"> Check torque limit signal. Check torque monitor and motor current. (For details, refer to the spindle controller manual.) 	<ul style="list-style-type: none"> Correct torque limitation. Replace spindle drive. Replace the spindle motor.
D/A circuit failure (output continues)	With the check connector CN3D of model JANCD-FC310 (or FC260) board, check that output voltage changes according to command. A3 (0 V) between A5 and A3 of 1st spindle and between A1 and A3 of 2nd spindle.	Replace model JANCD-FC310 (or FC260) board.
Failure of spindle controller (speed command continues)	Refer to the instruction manual of spindle drive.	Replace the spindle controller unit.
Wiring failure	Refer to Section 12 of YASNAC i80 Connecting Manual (TOE -C843-11.5).	Refer to Section 12 of YASNAC i80 Connecting Manual (TOE-C843-11.5).
Incorrect setting of PG magnification	Determine correct PG magnification from PG pulse count, gear ratio, ball-type screw pitch and compare it with parameter pm1053 to pm1056.	Set correct PG magnification.
Too low setting of Kp (position loop gain) causes excessive position lag. ---		If the setting is much smaller than the standard value set by machine manufacturer, enlarge parameter pm1417 (1st-spindle axis), pm1437 (2nd-spindle axis), pm1457 (3rd-spindle axis) and pm1477 (4th-spindle axis). See Section 5 for Kp adjustment method. For details, contact machine manufacturer.

a

4.2 TROUBLESHOOTING BY ALARM CODES (Cent'd)

4.2.13 ALARMS 3061 TO 3068 (MOTOR OVERLOAD)

Table 4.15

Cause of Trouble	Check Method	Solution
Cutting condition is too severe.	Did it occur during drilling and/or threadcutting ?	Wait until temperature of servo motor cools down. Then, restart operation by alleviating the condition.
Machine runs heavily due to shortage of lubricant on the guide face of machine.	Check the oil film on the guide face.	Check oil tank and oil pipe according to instruction manual of machine.
AC servo drive unit or FC300B failure	Motor overload alarm activates even if wiring is correct. It may cause an alarm.	Replace AC Servo drive unit or FC300B board. Contact your YASKAWA representative.

4.2.14 ALARMS 3081 TO 3088 (PG DISCONNECTION ERROR)

Signal wire disconnection check of A and B phases from PG.

Table 4.16

Cause of Trouble	Check Method	Solution
Disconnection or contact failure of signal wire between NC unit and AC servo drive unit	<ul style="list-style-type: none"> • Check for looseness and removal of FC300B board's connectors CN30, CN31, CN32. • Check looseness and removal of AC servo drive unit connectors. • Perform wiring check according to Connecting Manual (TOE-C843-11.5). 	<ul style="list-style-type: none"> • Correct looseness and/or removal of connectors. • Correct wiring as necessary.
Failure of PG detector circuit connection	This type of alarm results when main power is applied though result of check for above items are normal.	Replace FC300B. Contact your YASKAWA representative.
Motor model parameter setting error.	Check if "O" is set to motor model parameter (pm1061 to pm1068).	Set the motor model parameter (pm1061 to pm1068) correctly.

4.2.15 ALARMS 3091 TO 3094 (SPINDLE PG DISCONNECTION ERROR)

Signal wire disconnection of A, B, and C phases from spindle PG.

Table 4.17 Alarm 3091 (Spindle PG Disconnection Error)

Cause of Trouble	Check Method	Solution
Disconnection or contact failure of signal wire between NC unit and spindle controller	<ul style="list-style-type: none"> •Check for looseness and removal of model JANCD-FC310 board connectors CN34 (spindle FB). •Check for looseness and/or removal of spindle controller. •Perform wiring check according to Connecting Manual (T OE-C843-11.5). 	<ul style="list-style-type: none"> •Correct for looseness and/or removal of connectors. •Correct wiring as necessary.
No shorting plug connector even without spindle PG.	Shorting plug connector to CN34 or CN36 (with 2nd spindle) at model JANCD-FC310 board is required for such specifications without spindle PG.	Mount shorting plug connector.
Failure of PG detector circuit connection	Check whether this alarm occurs when main power is applied even though results of check for above items are normal.	Replace FC310 (or FC260). Contact your YASKAWA representative.
PG failure	If alarm occurs at slow rotation, PG may be defective.	Replace PG.

4

4.2.16 ALARMS 3121 TO3128 (EXCESSIVE SPEED)

These alarms are detected when a command for excessive speed is issued and motor rotation speed exceeds 1.2 times the maximum rotation speed.

Table 4.18 Alarms 3121 to 3125 (Excessive Speed)

Cause of Trouble	Check Method	Solution
Erroneous wiring of motor	Check wiring according to YASNAC i80 Connecting Manual (T OE-C843-11.5).	If erroneous wiring is found, correct the wiring.
Erroneous wiring of encoder	Check wiring according to YASNAC i80 Connecting Manual (TOE-C843-11.5).	If erroneous wiring is found, correct the wiring.
The movement distance per motor rotation is specified incorrectly.	Feed at low speed such as in handle mode, etc. It will be normal if the actual movement distance equals the position display change distance.	Determine correct movement distance (pm1821 to pm1825) per motor, rotation from gear ratio and ball-type screw pitch.

4.2 TROUBLESHOOTING BY ALARM CODES (Cent'd)

4.2.17 ALARMS 3141 TO 3148 (PREVENTION OF UNCONTROLLED RUNNING)

These alarms detect uncontrolled running due to erroneous wiring of the motor or encoder.

Table 4.19 Alarms 3141 to 3145 (Prevention of Uncontrolled Running)

Cause of Trouble	Check Method	Solution
Failure of model JANCD-FC300B board	Check whether the alarm is caused merely by application of control power.	Replace model JANCD-FC300B board.
Erroneous wiring of motor	Check wiring according to YASNAC i80 Connecting Manual (T OE-C843-11.5).	If erroneous wiring is found, correct the wiring.
Erroneous wiring of encoder	Check wiring according to YASNAC i80 Connecting Manual (TOE -C843-11.5).	If erroneous wiring is found, correct the wiring.
New incremental encoder pole sense input signal (phase C) malfunction (by noise)	Check whether alarm occurs often when primary power supply is turned on.	<ul style="list-style-type: none"> •Restart operation after turning off the power and then turning it on. •Provide some noise prevention.

4.2.18 ALARMS 3161 TO 3168 (ABSOLUTE ERRORS)

Malfunction of absolute encoder is detected.

Table 4.20 Alarms 3161 to 3165 (Absolute Errors)

Cause of Trouble	Check Method	Solution
Failure of model JANCD-FC300B board	Check whether the alarm is caused merely by application of control power.	Replace model JANCD-FC300B board.
Erroneous wiring of encoder	Check wiring according to YASNAC i80 Connecting Manual (TOE-C843-11.5).	If erroneous wiring is found, correct the wiring.
Malfunction of absolute encoder	Check whether alarm lamp goes out after power is turned off, then on again.	Restart operation after turning power off, then on again.
Malfunction of absolute encoder	Check whether the wiring of absolute encoder is correct and alarm occurs.	Retry setup of absolute encoder.
Backup-battery defective or not connected	Check whether battery alarm occurs at the same time.	Connect or replace backup battery.
Fault of absolute encoder	Check whether alarm occurs although all of the above check items are satisfied.	Replace the motor.

4.2.19 ALARMS 3181 TO 3188 (POSITION ERRORS)

Malfunction of PG pulse counter inside absolute encoder is detected.

Table 4.21 Alarms 3181 to 3188 (Position Errors)

Cause of Trouble	Check Method	Solution
Failure of model JANCD-FC300B board	Check whether the alarm is caused by mere application of control power.	Replace model JANCD-FC300B board.
Erroneous wiring of encoder	Check A, B, and C phase pulses using monitor board.	If erroneous wiring is found, correct the wiring.
Malfunction of PG pulse counter inside absolute encoder (due to noise)	Check whether the alarm occurs frequently during operation.	<ul style="list-style-type: none"> •Restart operation after turning power OFF, then ON again. •Take appropriate corrective action for noise.

A
a

4.2.20 ALARMS 3201 TO 3208 (SERVODRIVE UNIT COMMUNICATION ERRORS)

Serial communication error between NC and AC servodrive unit is detected.

Table 4.22 Alarms 3201 to 3208 (Servodrive Unit Communication Errors)

Cause of Trouble	Check Method	Solution
Erroneous wiring	Check wiring according to YASNAC i80 Connecting Manual (TOE-C843-11.5).	Refer to Section 11 of YASNAC i80 Connecting Manual (TOE-C843-11.5) and correct the wiring.
Wrong setting of AC servo drive unit ID switch	Check setting of ID switch of AC servo drive unit according to YASNAC i80 Connecting Manual (TOE-C843-11.5).	Refer to Section 11 of YASNAC i80 Connecting Manual (TOE-C843-11.5) and correct the setting.
Defective AC servodrive unit or model JANCD-FC300B board	Check whether the alarm occurs when the wiring and ID switch are not erroneous.	Replace model JANCD-FC300B board or AC servo drive unit. Contact your YASKAWA representative.

4.2 TROUBLESHOOTING BY ALARM CODES (Cent'd)

4.2.21 ALARMS 3301 TO 3305 (OVERCURRENT)

Table 4.23 Alarms 3301 to 3305 (Overcurrent)

Causeof Trouble	Check Method	Solution
Control board fault	Alarm occurs immediately after control power is turned ON.	Replace SERVOPACK.
Current feedback circuit error	Alarm occurs after main power is turned ON. MCCB is not tripped.	Replace SERVOPACK.
Main circuit transistor module error	Alarm occurs after main power is turned ON.	Replace SERVOPACK.
Motor grounding	Alarm occurs after main power is turned ON. MCCB is tripped.	Replace motor.

4.2.22 ALARMS 3311 TO 3315 (MCCB TRIP)

Table 4.24 Alarm s 3311 to 3315 (MCCB Trip)

Causeof Trouble	Check Method	Solution
Control board fault	Alarm occurs immediately after control power is turned ON.	Replace SERVOPACK.
Main circuit thyristor-diode module error	Alarm occurs after main power is turned ON.	Replace SERVOPACK.
MCCB failure	Alarm occurs after main power is turned ON.	Replace SERVOPACK.

4.2.23 ALARMS 3321 TO 3325 (REGENERATIVE ERROR)

Table 4.25 Alarms 3321 to 3325 (Regenerative Error)

Causeof Trouble	Check Method	Solution
Control board fault	Alarm occurs immediately after control power is turned ON.	Replace SERVOPACK.
Regenerative transistor error	Alarm occurs 0.5 to 1 second after main power is turned ON. MCCB is not tripped.	Replace SERVOPACK.
Wire break in regenerative resistor	Alarm occurs after main power is turned ON.	Replace SERVOPACK. Check regenerative resistor and replace if necessary.

4.2.24 ALARMS 3331 TO 3335 (OVERVOLTAGE)

Table 4.26 Alarms 3331 to 3335 (Overvoltage)

Cause of Trouble	Check Method	Solution
Excess load GD ₂ (WK ₂)	Alarm occurs when motor is started or slowed down.	Check load machine inertia converted into motor axis.
Regenerative processing circuit error	Alarm occurs when motor is started or slowed down.	Replace SERVOPACK.

4.2.25 ALARMS 3341 TO 3345 (UNDERVOLTAGE)

Table 4.27 Alarms 3341 to 3345 (Undervoltage)

Cause of Trouble	Check Method	Solution
Main circuit thyristor-diode module error	Alarm occurs after main circuit power is turned ON.	Replace SERVOPACK.

4

4.2.26 ALARMS 3351 TO 3355 (HEAT SINK OVERHEAT)

Table 4.28 Alarms 3351 to 3355 (Heat Sink Overheat)

Cause of Trouble	Check Method	Solution
Control board fault	Alarm occurs immediately after control power is turned ON.	Replace SERVOPACK.
Fan stops	Alarm occurs during operation. (If control power is turned OFF and then immediately turned ON again, alarm remains ON. Operation can be restarted only if system is reset after a while.)	Check whether fans running.
High ambient temperature near SERVOPACK (over 55°C 131°F)	Alarm occurs during operation. (If control power is turned OFF and then immediately turned ON again, alarm remains ON. Operation can be restarted only if system is reset after a while.)	Take necessary action to lower servopack ambient temperature.
Motor circuit connection error	Motor turns at low torque. Alarm occurs after a while.	Connect properly.

4.2 TROUBLESHOOTING BY ALARM CODES (Cent'd)

4.2.27 ALARMS 3361 TO 3365 (WIRE BREAK IN CURRENT INSTRUCTION CABLE)

Table 4.29 Alarms 3361 to 3365 (Wire Break in Current Instruction Cable)

Cause of Trouble	Check Method	Solution
Control board fault	Alarm occurs immediately after control power is turned ON.	Replace SERVOPACK.
Wire break or connection error between NC and SERVOPACK	Alarm occurs immediately after control power is turned ON.	Connect properly.
Other alarm (not really wire break in current instruction cable)	There is another alarm.	Correct causal alarm.

4.2.28 ALARMS 3371 TO 3375 (OPEN PHASE)

Table 4.30 Alarms 3371 to 3375 (Open Phase)

Cause of Trouble	Check Method	Solution
Control board fault	Alarm occurs immediately after control power is turned ON.	Replace SERVOPACK.
Imperfect connection of 3-phase power supply	Alarm occurs after main power is turned ON. MCCB is not tripped.	Connect properly.

4.3 TROUBLESHOOTING WITHOUT ALARM CODES

The following examples are instructions for locating and correcting the troubles not indicated by alarm codes. For further details of signal meanings expressed by the address DGN, refer to Section "Details of Signals" in Connecting Manual. (TOE-C843-11.5)

4.3.1 POWER CANNOT BE SUPPLIED

Table 4.31

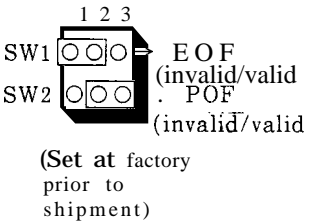
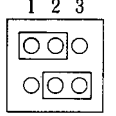
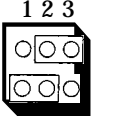
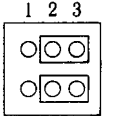
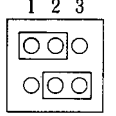
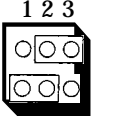
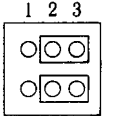
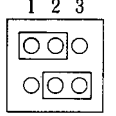
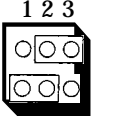
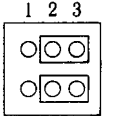
Cause of Trouble	Check Method	Solution																													
No power supplied to NC unit.	insure that SOURCE LED (green) of DC power supply(CPS-12N or -16F) inside CPU module lights.	Check molded-case circuit breaker or NC panel and also connector CN05 of CPS-12N or -16F.																													
Alarm LED of CPS-12N or-16F lights.	<p style="text-align: center;">CPS-12N or -16F LED Display</p> <table border="1" style="width: 100%; border-collapse: collapse;"> <thead> <tr> <th></th> <th>Signal Name</th> <th>Display</th> <th>LED Color</th> <th>Function & Cause</th> </tr> </thead> <tbody> <tr> <td rowspan="2" style="text-align: center; vertical-align: middle;">Normal</td> <td>Power supply status</td> <td>SOURCE</td> <td>Green</td> <td>Lights when AC power is on, out when power is off.</td> </tr> <tr> <td>Power on status</td> <td>POWER ON</td> <td>Green</td> <td>Lights when SOURCE input above 170 VAC at NCMX ON.</td> </tr> <tr> <td rowspan="4" style="text-align: center; vertical-align: middle;">Trouble Display</td> <td>+5 V Trouble</td> <td rowspan="3" style="text-align: center;">+5 v, ±12 v</td> <td rowspan="3" style="text-align: center;">Red</td> <td rowspan="3">Lights at +5 V overvoltage or overcurrent. Lights at +12 V overvoltage or 12 V undervoltage.</td> </tr> <tr> <td>+12 V Trouble</td> </tr> <tr> <td>-12 V Trouble</td> </tr> <tr> <td>+24 V Trouble</td> <td style="text-align: center;">+24 V</td> <td style="text-align: center;">Red</td> <td>Lights at +24 V overvoltage or overcurrent.</td> </tr> <tr> <td>External Trouble</td> <td style="text-align: center;">OHT/ EXT</td> <td style="text-align: center;">Red</td> <td>Lights with external EXALM signal, and overheat.</td> </tr> </tbody> </table> <p><small>Note</small> LED lights for external trouble (EXT) when CN05 connector between 4 and 7 short-circuits.</p>		Signal Name	Display	LED Color	Function & Cause	Normal	Power supply status	SOURCE	Green	Lights when AC power is on, out when power is off.	Power on status	POWER ON	Green	Lights when SOURCE input above 170 VAC at NCMX ON.	Trouble Display	+5 V Trouble	+5 v, ±12 v	Red	Lights at +5 V overvoltage or overcurrent. Lights at +12 V overvoltage or 12 V undervoltage.	+12 V Trouble	-12 V Trouble	+24 V Trouble	+24 V	Red	Lights at +24 V overvoltage or overcurrent.	External Trouble	OHT/ EXT	Red	Lights with external EXALM signal, and overheat.	<p>When trouble in Table on the left is displayed by LED, correct the trouble, then, turn ON power again. If the trouble is not corrected by this procedure, trouble may be in the power unit. Contact your YASKAWA representative (YASREP). If overcurrent causes the trouble and the cause is removed, the power supply can be turned on again after it is turned off. Unless the main circuit breaker is turned off and then on, the power supply cannot be turned on again even if the cause has been removed since the alarm circuit in the CPS cannot be reset.</p>
	Signal Name	Display	LED Color	Function & Cause																											
Normal	Power supply status	SOURCE	Green	Lights when AC power is on, out when power is off.																											
	Power on status	POWER ON	Green	Lights when SOURCE input above 170 VAC at NCMX ON.																											
Trouble Display	+5 V Trouble	+5 v, ±12 v	Red	Lights at +5 V overvoltage or overcurrent. Lights at +12 V overvoltage or 12 V undervoltage.																											
	+12 V Trouble																														
	-12 V Trouble																														
	+24 V Trouble	+24 V	Red	Lights at +24 V overvoltage or overcurrent.																											
External Trouble	OHT/ EXT	Red	Lights with external EXALM signal, and overheat.																												
Power ON/OFF Switch is not set properly. <div style="margin-top: 10px;">  </div>	<p style="text-align: center;">SW1 and SW2 Setting</p> <table border="1" style="width: 100%; border-collapse: collapse;"> <thead> <tr> <th></th> <th>Use panel (POF) only</th> <th>Use external device (E OF) only</th> <th>Use both</th> </tr> </thead> <tbody> <tr> <td style="text-align: center;">SW5 SW1 SW2</td> <td style="text-align: center;">  </td> <td style="text-align: center;">  </td> <td style="text-align: center;">  </td> </tr> </tbody> </table>		Use panel (POF) only	Use external device (E OF) only	Use both	SW5 SW1 SW2				Set correctly shorting plug SW1 and SW2 at left corner on JANCD-FC230B or FC260																					
	Use panel (POF) only	Use external device (E OF) only	Use both																												
SW5 SW1 SW2																															

A
a

4.3 TROUBLESHOOTING WITHOUT ALARM CODES (Cent'd)

4.3.2 SOLUTION TO ERRORS DETECTED IN SELF-DIAGNOSIS

Table 4.32 Solution to Errors Detected in Self-Diagnosis

Cause of Trouble	Check Method	Solution
Error identified by self-diagnosis	<ul style="list-style-type: none">• Both diagnostic items passed and the diagnostic item leading up to the error are displayed and the NC unit stops.• CPU cannot function normally and this is a major failure. The main system shuts off the servo power, but, depress the emergency stop and power OFF buttons to check for proper AC input voltage and ensure power is OFF.	<ul style="list-style-type: none">• Record the diagnostic item leading up to NC unit stop, turn on power again and contact your YASKAWA representative.• Remove any noise source near the NC unit. Turn on the main power under emergency stop conditions. Contact your YASKAWA representative immediately if it is "CPU ERROR". If normal, start operation after ensuring correct parameters, settings, offsets and programs.

4.3.2.1 SELF-DIAGNOSIS FUNCTIONS

Self-diagnosis functions are:

- (1) Memory Check
 - .CMOS check
 - .ROM check
 - .RAM check
- (2) System Consistency Check
- (3) Operation **Monitorin** g by Software
- (4) Operation Monitoring by Hardware
- (5) Division Error Detection
- (6) LED Display
- (7) Processing Program Area, Initialization Check
- (8) Expanded Memory Consistency Check
- (9) Axis Configuration Parameter Consistency Check
- (10) Overheat Detection
- (11) Battery Alarm Detection

4.3.2.2 DETAILS OF FUNCTION

(1) Memory Check

Backup memory CMOS existing only in model JAN CD-FC200 board and ROM/RAM memory on all CPU boards are self-diagnosed.

Self-diagnosis includes items checked at system startup and after startup.

(a) CMOS Check

(i) Total Check

Total check is made after system startup and CMOS error is detected by total check sum on CMOS memory.

This check is performed or not depending on the system number.

Numbers checked . . . "0" "1" "2" "4"

When an error occurs in CMOS, the following alarms are generated:

Alarm	ALM1090: Setting total check error ALM1091: Parameter total check error ALM1092: Keep memory total check error ALM1093: Offset total check error ALM1094: Macro program variable total check error ALM1095: Processing program total check error
-------	---

If an alarm occurs for some reason, CMOS data may be destroyed. The alarm can be erased by temporarily writing the data from the CRT control panel, then depressing the  key on the control panel.

Note

No alarm can be erased for processing programs.

4.3 TROUBLESHOOTING WITHOUT ALARM CODES (Cent'd)

(ii) Power-off Check

A check is made at system srartup to see if CMOS data to be backed up from each CPU was saved correctly at previous power off.

This check is performed or not depending on the system number.

Numbers checked . . . "0" "1" "2" "4"

When an error occurs in CMOS, the following alarms are generated:

Alarm	ALM3270: power-off error (keep memory) ALM3271: Power-off error (tool life management) ALM3272: Power-off error (macro program) ALM3273: Power-off error (internal memory)
-------	--

(b) ROM Check

ROM check consists of total check on ROMs of all CPUs, whether at system start up or after startup. When an optional function is added, its memory area is also checked.

This check is performed or not depending on system number.

Numbers checked ... "0" "1" "2" "4"

When an error occurs in ROM, the board in which the error occurs, and its ROM number are displayed

CPU in which an error occurs and its ROM number	FC190	190, 191, 192, 193, 194, 195, 196, 197, 198, 199, 200, 201, 202, 203
	FC210	210
	FC222/FC224	200, 221, 222, 223, 224, 225, 226, 227
	FC230B	230, 231
	FC250/FC251	250, 251 (i80B)
	FC260	260, 261 (i80B)
	FC265	265 (i80B)
	FC240/FC241	240, 245
	FC300B	300
	FC310	310

(c) RAM Check

RAM check is performed to see if RAMs of all CPUS operate normally at system startup. RAM check is conducted for all system numbers.

An error is displayed only when the system operates with the following system numbers:

Displayable numbers ... "0" "1" "2"

The CPU in which an error occurred and its RAM number are shown below.

FC200	:	04, 05
FC190	:	BASIC 00~03 , 06~11 OP 12~13
FC210	:	00~02 ISD 04~09
FC222/FC224	:	00-09
FC230B	:	00, 01
FC240/FC241	:	00-05
FC250/FC251	:	00~05 (i80B)
FC260"	:	00~03 (i80B)
FC265	:	00~01 (i80B)
FC300B	:	00-03
FC310	:	00

(2) System Consistency

See (c) of (5) of Par. 4.1.2.

4.3 TROUBLESHOOTING WITHOUT ALARM CODES (Cent'd)

(3) Operation Monitoring by Software

Normal operation of the entire system is monitored by software.

System software checks whether a partner CPU is normally operating among CPUs. If the partner CPU is stopped, an alarm occurs.

Numbers checked . . . "0", "1", "2", "4"
--

Alarm	ALM3260 : SMON-INTEX Synchronous error ALM3261 : SMON-MMON Synchronous error/ SMON-MOTION Synchronous error (i80B) ALM3262 : MMON-MG Synchronous error ALM3263 : MMON-PLC Synchronous error /MOTION-PLC Synchronous error (i80B) ALM3264 : MG-AXIS Synchronous error/MOTION-AXIS Synchronous error (i80B) ALM3265 : ACGC Synchronous error ALM3266 : DNC Synchronous error
-------	--

(4) Operation Monitoring by Hardware

Normal operation of system software is monitored by hardware. This is performed for specific system numbers.

When system software does not access hardware for a given period, it is regarded as a hardware failure and a hardware monitoring error is displayed.

Numbers checked . . . "0", "1", "2", "4"
--

(5) Division Error

A division error occurring in system software is detected and the entire system is stopped. The address in which the division error occurred is displayed on the screen.

(6) LED Display

Self-diagnosis results are displayed on 7-segment LED on the model JAN CD-FC200 board.

- (a) Initial Self-Diagnosis Status Display at Power on
- Pass indication is made on the initial self-diagnosis display screen at power on. At the same time, the same number as in the pass indication is displayed on the 7-segment LED.

Self-diagnosis status contents	<ul style="list-style-type: none">0: Local RAM check path (FC200)1: Bus gate set path<ul style="list-style-type: none">i80 : (FC200, FC210, FC222/FC224, FC230B, FC240/FC241)i80B : (FC200, FC210, FC250/FC251, FC260)2: A-common RAM check path3: CPU activation check path among FC200, FC210, FC222/FC224, FC230B and FC240/FC241 (i80) CPU activation check path among FC200, FC210, FC250/FC251, FC260 and FC265 (i80B)4: Option RAM check path (FC190) & system configuration parameter information transfer path5: First request path from model JANCD-FC2006: Operation processor initialization & self-diagnosis7: Path for supplying a clock to each CPU8: Parameter common, local RAM transfer path9: Common and local RAM transfer paths of offset and macro informationA: CMOS fixed file check path (screen 10)B: Inter-CPU regular operation check started (screen 11)C: CPU normal mode setup completed (except for FC200) (screen 12).D: CPU normal mode (except for FC200) (screen 13)
--------------------------------	---

4

(b) System Operation Display

The point of the 7-segment LED blinks about every one second. The system is operating normally while it is blinking.

4.3 TROUBLESHOOTING WITHOUT ALARM CODES (Cent'd)

(c) System Error Indication

When a major error occurs in the system, the entire system is stopped, a system error is displayed on the screen, and the contents are displayed on 7-segment LED as well.

System error display contents	<ul style="list-style-type: none">1: Watchdog error2: ROM check error3: Packet communication ID error4: Packet communication packet length error5: Packet communication check sum error6: Packet communication data length error7: Packet communication undefined function error8: Packet communication undefined command issue error9: Packet communication undefined code errorA: Division errorB: Undefined interrupt errorC: File operation error
-------------------------------	--

(7) Processing Program Area, Initialization Check

At power ON, a check is made to see if the processing program area was initialized previously with all system numbers and is available for use. An alarm occurs when the processing program area was initialized, and when initialization was performed but CMOS destruction may occur due to a weak battery.

Alarm
ALM3010: Processing program memory not initialized

(8) Expanded Memory Consistency Check

When the processing program area is provided with expanded memory, since the memory capacity of memory board varies, a consistency check is performed to prohibit the use of expanded memory in a fault state.

When the processing program area is initialized with all system numbers, a check is made for the same memory length as the expanded memory board. Otherwise, an alarm occurs.

Alarm

ALM3011: Processing program expanded memory
unmatch

4

(9) Axis Configuration Parameter Consistency Check

After a check is made at power ON for consistency between the configuration of physical axis and axis configuration parameters, if axis parameters determining conditions of system operation are not specified correctly, the operation is prohibited.

Detailed explanation follows. A check is made to see if axis type in physical axis information and parameter axis information is specified correctly for feed axis and spindle. A check is made to see if the number of physical axis is greater than the number of parameter axis, and if specification of three axis for one slot is consistent between physical axis and parameters.

Alarm

ALM3012: Axis configuration parameter unmatch

4.3 TROUBLESHOOTING WITHOUT ALARM CODES (Cent'd)

(1 O) Overheat Detection

Power overheat is always checked after system startup, and upon detection of overheat, an alarm occurs.

Alarm

ALM1099: Abnormality of panel temperature

(11) Battery Alarm Detection

Voltage drop due to an exhausted battery is detected after system startup and a battery alarm is displayed on the screen.

Once a battery alarm occurs, alarm indication on the screen is not erased by replacing the battery. Turn power OFF, then ON again.

4.3.3 CRT SCREEN DOES NOT DISPLAY

CRT screen may not display any data as a result of trouble of CRT unit itself, display circuit and/or connection cable. If there is no display on the screen even after the NC unit power is applied, check to ensure that the wire is properly connected to the NC operator's station, connectors are not loose, or fuse inside CRT unit is not blown (refer to Par. 4.3.11 9, "CRT SCREEN IS DARK").

Contact your YASKAWA representative, if the trouble can not be located even after the above procedure.

4.3.4 HANDLE MODE OPERATION FAULTY

Table 4.33

Cause of Trouble	Check Method	Solution
HANDLE mode signal not entered.	<ul style="list-style-type: none"> • I/O signal #3000 $D_2 = 1$ Bit set to 0? All other bits (D_0, D_1, D_3 through D_7) must be set to 0. • Check the mode indication in the stationary display field on the screen. 	Select HANDLE mode. Check mode switch wiring.
Axis selection signal not entered.	<p>Confirm that one optional axis of the Following axes is entered:</p> <p>[I/O signal #3070 $D_0 = 1$ (1st-axis) $D_1 = 1$ (2nd-axis) $D_2 = 1$ (3rd-axis) $D_3 = 1$ (4th-axis) $D_4 = 1$ (5th-axis) $D_5 = 1$ (6th-axis) $D_6 = 1$ (7th-axis) $D_7 = 1$ (8th-axis)</p> <ul style="list-style-type: none"> • For second handle #3080 $D_0 = 1$ (1st-axis) $D_1 = 1$ (2nd-axis) $D_2 = 1$ (3rd-axis) $D_3 = 1$ (4th-axis) $D_4 = 1$ (5th-axis) $D_5 = 1$ (6th-axis) $D_6 = 1$ (7th-axis) $D_7 = 1$ (8th-axis) • For third handle #3081 $D_0 = 1$ (1st-axis) $D_1 = 1$ (2nd-axis) $D_2 = 1$ (3rd-axis) $D_3 = 1$ (4th-axis) $D_4 = 1$ (5th-axis) $D_5 = 1$ (6th-axis) $D_6 = 1$ (7th-axis) $D_7 = 1$ (8th-axis) 	Select an axis. Check the axis selection switch wiring.

A
a

4.3 TROUBLESHOOTING WITHOUT ALARM CODES (Cent'd)

Table 4.33 (Cent'd)

Cause of Trouble	check Method	Solution		
Power is not supplied to HANDLE PG.	Check that +5 V is supplied on terminal of handle PG. Confirm that the HANDLE PG signal connector is not removed.	Refer to “ Manual pulse generator” of the Connecting Manual to check the wiring, and wire correctly.		
Two or three handles		Set option parameters.		
HANDLE PG trouble FC903 board trouble	This is a counter monitor. Confirm that #3037 (one handle), #3038 (two handles), #3039 (three handles) values changes when HANDLE PG is turned.	Replace HANDLE PG.		
Manual pulsing magnification input is selected.	Manual pulsing magnification input I/O signal #3002			
	D ₇ MP4	D ₆ MP2	D ₅ MP1	Magnification
	0	0	0	x 1
	0		1	x 10
	0	1	0	x 100
	0	1	1	x 100
	1	Either 0 or 1		x 100
Others: Related parameters	The max_speed in HANDLE mode $\boxed{\text{PRM}}$ pm2860 (linear axis) $\boxed{\text{PRM}}$ pm2861 (rotation axes) Time constant at accel/decel in HANDLE mode $\boxed{\text{PRM}}$ pm2561 - pm2568 Optional magnification setting at magnification $\times 100$ selection time (For pm2003 D ₇ = 1) $\boxed{\text{PRM}}$ pm2459	Verify it with the parameter table attached at the factory prior to shipment.		

4.3.5 MANUAL JOG MODE OPERATION FAULTY

Table 4.34 Manual Jog Mode Operation Faulty

Cause of Trouble	Check Method	Solution								
Jog mode not selected signal	Check whether I/O signal #3000 D ₀ is 1. All other bits (D ₀ , D ₂ to D ₇) must be set to 0. [In i80L multi-program system, check #3050 for second program and #3060 for third program.]	Select JOG mode. Check mode wiring switch.								
Jog axial direction not input	Check the following I/O signals: #3071 D ₀ (+1st-axis) #3071 D ₅ (+6th-axis) #3072 D ₀ (-1st-axis) #3072 D ₅ (-6th-axis) #3071 D ₁ (+2nd-axis) #3071 D ₆ (+7th-axis) #3072 D ₁ (-2nd-axis) #3072 D ₆ (-7th-axis) #3071 D ₂ (+3rd-axis) #3071 D ₇ (+8th-axis) #3072 D ₂ (-3rd-axis) #3072 D ₇ (-8th-axis) #3071 D ₃ (+4th-axis) #3072 D ₃ (-4th-axis) #3071 D ₄ (+5th-axis) #3072 D ₄ (-5th-axis)	Check the push button switch or selection switch wiring. In some cases, it is handled as a prohibited item for the sequence. Refer to the machine manufacturer's reference manuals for details.								
Jog speed signal not input. The setting of jog speed parameter is in error.	Feed Override/Manual JOG Feed Rate Selection					Manual JOG Feed Rate (Manual Operation Mode)				
	Step	I/O signal #3002								
		D ₄	D ₃	D ₂	D ₁		D ₀			
		JV	JV	JV	JV		JV			
		16	8	4	2		1			
	1	0	0	0	0		0	Parameter pm2400 Setting speed		
	2	0	0	0	0		1	Parameter pm2401 Setting speed		
	3	0	0	0	1		0	Parameter pm2402 Setting speed		
	4	0	0	0	1		1	Parameter pm2403 Setting speed		
	5	0	0	1	0		0	Parameter pm2404 Setting speed		
	6	0	0	1	0		1	Parameter pm2405 Setting speed		
	7	0	0	1	1		0	Parameter pm2406 Setting speed		
	8	0	0	1	1		1	Parameter pm2407 Setting speed		
	9	0	1	0	0		0	Parameter pm2408 Setting speed		
	10	0	1	0	0		1	Parameter pm2409 Setting speed		
		1	1	1	0		1	1	0	Parameter pm2410 Setting speed
	12	0	1	0	1		1	Parameter pm2411 Setting speed		
	13	0	1	1	0		0	Parameter pm2412 Setting speed		
14	0	1	1	0	1	Parameter pm2413 Setting speed				
15	0	1	1	1	0	Parameter pm2414 Setting speed				
16	0	1	1	1	1	Parameter pm2415 Setting speed				
17	1	0	0	0	0	Parameter pm2416 Setting speed				



4.3 TROUBLESHOOTING WITHOUT ALARM CODES (Cent'd)

Table 4.34 Manual Jog Mode Operation Faulty (Cent'd)

Cause of Trouble	Check Method	Solution																																																																																																																										
	<p style="text-align: center;">Feed Override/Manual JOG Feed Rate Selection (Cent'd)</p> <table border="1" style="width: 100%; border-collapse: collapse;"> <thead> <tr> <th rowspan="3">Step</th> <th colspan="5">I/O signal #3002</th> <th rowspan="3">Manuel JOG Feed Rate (Manual Operation Mode)</th> </tr> <tr> <th>D₄</th> <th>D₃</th> <th>D₂</th> <th>D₁</th> <th>D₀</th> </tr> <tr> <th>JV 16</th> <th>JV 8</th> <th>JV 4</th> <th>JV 2</th> <th>JV 1</th> </tr> </thead> <tbody> <tr> <td>18</td> <td>1</td> <td>0</td> <td>0</td> <td>0</td> <td>1</td> <td>Parameter pm2417 Setting speed</td> </tr> <tr> <td>19</td> <td>1</td> <td>0</td> <td>0</td> <td>1</td> <td>0</td> <td>Parameter pm2418 Setting speed</td> </tr> <tr> <td>20</td> <td>1</td> <td>0</td> <td>0</td> <td>1</td> <td>1</td> <td>Parameter pm2419 Setting speed</td> </tr> <tr> <td>21</td> <td>1</td> <td>0</td> <td>1</td> <td>0</td> <td>0</td> <td>Parameter pm2420 Setting speed</td> </tr> <tr> <td>22</td> <td>1</td> <td>0</td> <td>1</td> <td>0</td> <td>1</td> <td>Parameter pm2421 Setting speed</td> </tr> <tr> <td>23</td> <td>1</td> <td>0</td> <td>1</td> <td>1</td> <td>0</td> <td>Parameter pm2422 Setting speed</td> </tr> <tr> <td>24</td> <td>1</td> <td>0</td> <td>1</td> <td>1</td> <td>1</td> <td>Parameter pm2423 Setting speed</td> </tr> <tr> <td>25</td> <td>1</td> <td>1</td> <td>0</td> <td>0</td> <td>0</td> <td>Parameter pm2424 Setting speed</td> </tr> <tr> <td>26</td> <td>1</td> <td>1</td> <td>0</td> <td>0</td> <td>1</td> <td>Parameter pm2425 Setting speed</td> </tr> <tr> <td>27</td> <td>1</td> <td>1</td> <td>0</td> <td>1</td> <td>0</td> <td>Parameter pm2426 Setting speed</td> </tr> <tr> <td>28</td> <td>1</td> <td>1</td> <td>0</td> <td>1</td> <td>1</td> <td>Parameter pm2427 Setting speed</td> </tr> <tr> <td>29</td> <td>1</td> <td>1</td> <td>1</td> <td>0</td> <td>0</td> <td>Parameter pm2428 Setting speed</td> </tr> <tr> <td>30</td> <td>1</td> <td>1</td> <td>1</td> <td>0</td> <td>1</td> <td>Parameter pm2429 Setting speed</td> </tr> <tr> <td>31</td> <td>1</td> <td>1</td> <td>1</td> <td>1</td> <td>0</td> <td>Parameter pm2430 Setting speed</td> </tr> <tr> <td>32</td> <td>1</td> <td>1</td> <td>1</td> <td>1</td> <td>1</td> <td>Parameter pm2431 Setting speed</td> </tr> </tbody> </table> <p>In i80L multi-program system, check #3052 for second program and #3062 for third program. Does I/O signal #3002 (#3052, #3072) change according to the list when the jog speed selection switch is changed? Are parameters pm2400 to pm2431 set correctly?</p>	Step	I/O signal #3002					Manuel JOG Feed Rate (Manual Operation Mode)	D ₄	D ₃	D ₂	D ₁	D ₀	JV 16	JV 8	JV 4	JV 2	JV 1	18	1	0	0	0	1	Parameter pm2417 Setting speed	19	1	0	0	1	0	Parameter pm2418 Setting speed	20	1	0	0	1	1	Parameter pm2419 Setting speed	21	1	0	1	0	0	Parameter pm2420 Setting speed	22	1	0	1	0	1	Parameter pm2421 Setting speed	23	1	0	1	1	0	Parameter pm2422 Setting speed	24	1	0	1	1	1	Parameter pm2423 Setting speed	25	1	1	0	0	0	Parameter pm2424 Setting speed	26	1	1	0	0	1	Parameter pm2425 Setting speed	27	1	1	0	1	0	Parameter pm2426 Setting speed	28	1	1	0	1	1	Parameter pm2427 Setting speed	29	1	1	1	0	0	Parameter pm2428 Setting speed	30	1	1	1	0	1	Parameter pm2429 Setting speed	31	1	1	1	1	0	Parameter pm2430 Setting speed	32	1	1	1	1	1	Parameter pm2431 Setting speed	<p>Check wiring of the jog speed selection switch. Set the command speed or the number of necessary steps in parameters pm2400 to pm2431.</p>
Step	I/O signal #3002					Manuel JOG Feed Rate (Manual Operation Mode)																																																																																																																						
	D ₄		D ₃	D ₂	D ₁		D ₀																																																																																																																					
	JV 16	JV 8	JV 4	JV 2	JV 1																																																																																																																							
18	1	0	0	0	1	Parameter pm2417 Setting speed																																																																																																																						
19	1	0	0	1	0	Parameter pm2418 Setting speed																																																																																																																						
20	1	0	0	1	1	Parameter pm2419 Setting speed																																																																																																																						
21	1	0	1	0	0	Parameter pm2420 Setting speed																																																																																																																						
22	1	0	1	0	1	Parameter pm2421 Setting speed																																																																																																																						
23	1	0	1	1	0	Parameter pm2422 Setting speed																																																																																																																						
24	1	0	1	1	1	Parameter pm2423 Setting speed																																																																																																																						
25	1	1	0	0	0	Parameter pm2424 Setting speed																																																																																																																						
26	1	1	0	0	1	Parameter pm2425 Setting speed																																																																																																																						
27	1	1	0	1	0	Parameter pm2426 Setting speed																																																																																																																						
28	1	1	0	1	1	Parameter pm2427 Setting speed																																																																																																																						
29	1	1	1	0	0	Parameter pm2428 Setting speed																																																																																																																						
30	1	1	1	0	1	Parameter pm2429 Setting speed																																																																																																																						
31	1	1	1	1	0	Parameter pm2430 Setting speed																																																																																																																						
32	1	1	1	1	1	Parameter pm2431 Setting speed																																																																																																																						
An axis interlock signal is entered.	<p>Jog is correct when: #3078 D₀ = 1 (1st-axis) #3078 D₅ = 1 (6th-axis) #3078 D₁ = 1 (2nd-axis) #3078 D₆ = 1 (7th-axis) #3078 D₂ = 1 (3rd-axis) #3078 D₇ = 1 (8th-axis) #3078 D₃ = 1 (4th-axis) #3078 D₄ = 1 (5th-axis)</p> <p>When O, the axis does not work.</p>	An axis interlock signal is entered for some reason. Refer to the manual of the machine manufacturer to release the axis interlock.																																																																																																																										
The machine is in LOCK position.	<p>The position display changes in MACHINE LOCK mode. Check the machine lock switch input. I/O signal #3006 D₅ (In i80L multi-program system, #3056 D₅ for second program and #3066 D₅ for third program.) Check the internal torque switch. Setting #0000 D, (In i80L multi-program system, #0024 D₁ for second program and #0027 D₁ for third program.)</p>	<p>Check wiring of the machine lock switch Set pm0000 (pm0024, pm0027) D₁ to O.</p>																																																																																																																										

4.3.6 MANUAL RAPID MODE OPERATION FAULTY

Table 4.35 Manual Rapid Mode Operation Faulty

Cause of Trouble	Check Method	Solution																																																																		
Rapid mode not selected	Check I/O signal #3000 D ₀ = 1. (In i80L multi-program system, check #3050 for second program and #3060 for third program.) All other bits (D ₁ to D ₇) must be set 0.	Select mode. Check the wiring.																																																																		
Axial direction specification is not selected.	Check the following I/O signals: <table style="width:100%; border:none;"> <tr> <td>#3071 D₀ (+1st-axis)</td> <td>#3072 D₂ (-3rd-axis)</td> <td>#3071 D₅ (+6th-axis)</td> </tr> <tr> <td>#3072 D₀ (-1st-axis)</td> <td>#3071 D₃ (+4th-axis)</td> <td>#3072 D₅ (-6th-axis)</td> </tr> <tr> <td>#3071 D₁ (+2nd-axis)</td> <td>#3072 D₃ (-4th-axis)</td> <td>#3071 D₆ (+7th-axis)</td> </tr> <tr> <td>#3072 D₁ (-2nd-axis)</td> <td>#3071 D₄ (+5th-axis)</td> <td>#3072 D₆ (-7th-axis)</td> </tr> <tr> <td>#3071 D₂ (+3rd-axis)</td> <td>#3072 D₄ (-5th-axis)</td> <td>#3071 D₇ (+8th-axis)</td> </tr> <tr> <td></td> <td></td> <td>#3072 D₇ (-8th-axis)</td> </tr> </table>	#3071 D ₀ (+1st-axis)	#3072 D ₂ (-3rd-axis)	#3071 D ₅ (+6th-axis)	#3072 D ₀ (-1st-axis)	#3071 D ₃ (+4th-axis)	#3072 D ₅ (-6th-axis)	#3071 D ₁ (+2nd-axis)	#3072 D ₃ (-4th-axis)	#3071 D ₆ (+7th-axis)	#3072 D ₁ (-2nd-axis)	#3071 D ₄ (+5th-axis)	#3072 D ₆ (-7th-axis)	#3071 D ₂ (+3rd-axis)	#3072 D ₄ (-5th-axis)	#3071 D ₇ (+8th-axis)			#3072 D ₇ (-8th-axis)	Select axial direction. Check the wiring.																																																
#3071 D ₀ (+1st-axis)	#3072 D ₂ (-3rd-axis)	#3071 D ₅ (+6th-axis)																																																																		
#3072 D ₀ (-1st-axis)	#3071 D ₃ (+4th-axis)	#3072 D ₅ (-6th-axis)																																																																		
#3071 D ₁ (+2nd-axis)	#3072 D ₃ (-4th-axis)	#3071 D ₆ (+7th-axis)																																																																		
#3072 D ₁ (-2nd-axis)	#3071 D ₄ (+5th-axis)	#3072 D ₆ (-7th-axis)																																																																		
#3071 D ₂ (+3rd-axis)	#3072 D ₄ (-5th-axis)	#3071 D ₇ (+8th-axis)																																																																		
		#3072 D ₇ (-8th-axis)																																																																		
Rapid override not input	<p style="text-align:center;">Input Status and Rapid Traverse Rate</p> <table border="1" style="width:100%; border-collapse: collapse;"> <thead> <tr> <th colspan="2">I/O Signal #3003 Input Status</th> <th colspan="4">Rapid Traverse Rate</th> </tr> <tr> <th>ROV2</th> <th>ROV1</th> <th>1st-axis</th> <th>2nd-axis</th> <th>3rd-axis</th> <th>4th-axis</th> </tr> </thead> <tbody> <tr> <td>1</td> <td>1</td> <td>pm2801 Setting speed</td> <td>pm2802 Setting speed</td> <td>pm2803 Setting speed</td> <td>pm2804 Setting speed</td> </tr> <tr> <td>1</td> <td>0</td> <td>$\left(\frac{\text{pm2801 Setting speed}}{2}\right)$</td> <td>$\left(\frac{\text{pm2802 Setting speed}}{2}\right)$</td> <td>$\left(\frac{\text{pm2803 Setting speed}}{2}\right)$</td> <td>$\left(\frac{\text{pm2804 Setting speed}}{2}\right)$</td> </tr> <tr> <td>0</td> <td>1</td> <td>$\left(\frac{\text{pm2801 Setting speed}}{4}\right)$</td> <td>$\left(\frac{\text{pm2802 Setting speed}}{4}\right)$</td> <td>$\left(\frac{\text{pm2803 Setting speed}}{4}\right)$</td> <td>$\left(\frac{\text{pm2804 Setting speed}}{4}\right)$</td> </tr> <tr> <td>0</td> <td>0</td> <td colspan="4" style="text-align:center;">F₀ (#2447 Setting speed)</td> </tr> <tr> <th>ROV2</th> <th>ROV1</th> <th>5th-axis</th> <th>6th-axis</th> <th>7th-axis</th> <th>8th-axis</th> </tr> <tr> <td>1</td> <td>1</td> <td>pm2805 Setting speed</td> <td>pm2806 Setting speed</td> <td>pm2807 Setting speed</td> <td>pm2808 Setting speed</td> </tr> <tr> <td>1</td> <td>0</td> <td>$\left(\frac{\text{pm2805 Setting speed}}{2}\right)$</td> <td>$\left(\frac{\text{pm2806 Setting speed}}{2}\right)$</td> <td>$\left(\frac{\text{pm2807 Setting speed}}{2}\right)$</td> <td>$\left(\frac{\text{pm2808 Setting speed}}{2}\right)$</td> </tr> <tr> <td>0</td> <td>1</td> <td>$\left(\frac{\text{pm2805 Setting speed}}{4}\right)$</td> <td>$\left(\frac{\text{pm2806 Setting speed}}{4}\right)$</td> <td>$\left(\frac{\text{pm2807 Setting speed}}{4}\right)$</td> <td>$\left(\frac{\text{pm2808 Setting speed}}{4}\right)$</td> </tr> <tr> <td>0</td> <td>0</td> <td colspan="4" style="text-align:center;">F₃ (#2447 Setting speed)</td> </tr> </tbody> </table> <p> 1. 0: Open 1: Closed 2. Rapid override. 6-step specifications are as shown below. (6-step specifications: Parameter pm2000 D₃₌₁) 3. In i80L multi-program system, check #3053 for second program and #3063 for third program. </p>	I/O Signal #3003 Input Status		Rapid Traverse Rate				ROV2	ROV1	1st-axis	2nd-axis	3rd-axis	4th-axis	1	1	pm2801 Setting speed	pm2802 Setting speed	pm2803 Setting speed	pm2804 Setting speed	1	0	$\left(\frac{\text{pm2801 Setting speed}}{2}\right)$	$\left(\frac{\text{pm2802 Setting speed}}{2}\right)$	$\left(\frac{\text{pm2803 Setting speed}}{2}\right)$	$\left(\frac{\text{pm2804 Setting speed}}{2}\right)$	0	1	$\left(\frac{\text{pm2801 Setting speed}}{4}\right)$	$\left(\frac{\text{pm2802 Setting speed}}{4}\right)$	$\left(\frac{\text{pm2803 Setting speed}}{4}\right)$	$\left(\frac{\text{pm2804 Setting speed}}{4}\right)$	0	0	F ₀ (#2447 Setting speed)				ROV2	ROV1	5th-axis	6th-axis	7th-axis	8th-axis	1	1	pm2805 Setting speed	pm2806 Setting speed	pm2807 Setting speed	pm2808 Setting speed	1	0	$\left(\frac{\text{pm2805 Setting speed}}{2}\right)$	$\left(\frac{\text{pm2806 Setting speed}}{2}\right)$	$\left(\frac{\text{pm2807 Setting speed}}{2}\right)$	$\left(\frac{\text{pm2808 Setting speed}}{2}\right)$	0	1	$\left(\frac{\text{pm2805 Setting speed}}{4}\right)$	$\left(\frac{\text{pm2806 Setting speed}}{4}\right)$	$\left(\frac{\text{pm2807 Setting speed}}{4}\right)$	$\left(\frac{\text{pm2808 Setting speed}}{4}\right)$	0	0	F ₃ (#2447 Setting speed)				Select override and set parameters.
I/O Signal #3003 Input Status		Rapid Traverse Rate																																																																		
ROV2	ROV1	1st-axis	2nd-axis	3rd-axis	4th-axis																																																															
1	1	pm2801 Setting speed	pm2802 Setting speed	pm2803 Setting speed	pm2804 Setting speed																																																															
1	0	$\left(\frac{\text{pm2801 Setting speed}}{2}\right)$	$\left(\frac{\text{pm2802 Setting speed}}{2}\right)$	$\left(\frac{\text{pm2803 Setting speed}}{2}\right)$	$\left(\frac{\text{pm2804 Setting speed}}{2}\right)$																																																															
0	1	$\left(\frac{\text{pm2801 Setting speed}}{4}\right)$	$\left(\frac{\text{pm2802 Setting speed}}{4}\right)$	$\left(\frac{\text{pm2803 Setting speed}}{4}\right)$	$\left(\frac{\text{pm2804 Setting speed}}{4}\right)$																																																															
0	0	F ₀ (#2447 Setting speed)																																																																		
ROV2	ROV1	5th-axis	6th-axis	7th-axis	8th-axis																																																															
1	1	pm2805 Setting speed	pm2806 Setting speed	pm2807 Setting speed	pm2808 Setting speed																																																															
1	0	$\left(\frac{\text{pm2805 Setting speed}}{2}\right)$	$\left(\frac{\text{pm2806 Setting speed}}{2}\right)$	$\left(\frac{\text{pm2807 Setting speed}}{2}\right)$	$\left(\frac{\text{pm2808 Setting speed}}{2}\right)$																																																															
0	1	$\left(\frac{\text{pm2805 Setting speed}}{4}\right)$	$\left(\frac{\text{pm2806 Setting speed}}{4}\right)$	$\left(\frac{\text{pm2807 Setting speed}}{4}\right)$	$\left(\frac{\text{pm2808 Setting speed}}{4}\right)$																																																															
0	0	F ₃ (#2447 Setting speed)																																																																		

4

4.3 TROUBLESHOOTING WITHOUT ALARM CODES (cent'd)

Table 4.35 Manual Rapid Mode Operation Faulty (Cent'd)

Cause of Trouble	Check Method	Solution																																
Rapid override not input	<p>For 6 steps specifications</p> <table border="1" data-bbox="261 464 1263 793"> <thead> <tr> <th colspan="3">Input Status</th> <th>Rapid Traverse Rate</th> </tr> <tr> <th>ROV4</th> <th>ROV2</th> <th>ROV1</th> <th>1st-axis to 8th-axis</th> </tr> </thead> <tbody> <tr> <td>1</td> <td>0</td> <td>1</td> <td>F₂ (pm2449 Setting speed)</td> </tr> <tr> <td>1</td> <td>0</td> <td>0</td> <td>F₁ (pm2448 Setting speed)</td> </tr> <tr> <td>0</td> <td>1</td> <td>1</td> <td>100%</td> </tr> <tr> <td>0</td> <td>1</td> <td>0</td> <td>50%</td> </tr> <tr> <td>0</td> <td>0</td> <td>1</td> <td>25%</td> </tr> <tr> <td>0</td> <td>0</td> <td>0</td> <td>F₀ (pm2447 Setting speed)</td> </tr> </tbody> </table>	Input Status			Rapid Traverse Rate	ROV4	ROV2	ROV1	1st-axis to 8th-axis	1	0	1	F ₂ (pm2449 Setting speed)	1	0	0	F ₁ (pm2448 Setting speed)	0	1	1	100%	0	1	0	50%	0	0	1	25%	0	0	0	F ₀ (pm2447 Setting speed)	Select override and set parameters.
Input Status			Rapid Traverse Rate																															
ROV4	ROV2	ROV1	1st-axis to 8th-axis																															
1	0	1	F ₂ (pm2449 Setting speed)																															
1	0	0	F ₁ (pm2448 Setting speed)																															
0	1	1	100%																															
0	1	0	50%																															
0	0	1	25%																															
0	0	0	F ₀ (pm2447 Setting speed)																															
Parameters not set correctly	<p>Check the following I/O signals:</p> <table border="0" data-bbox="367 877 1252 993"> <tr> <td>pm2801 1st-axis rapid traverse rate</td> <td>pm2805 5th-axis rapid traverse rate</td> </tr> <tr> <td>pm2802 2nd-axis rapid traverse rate</td> <td>pm2806 6th-axis rapid traverse rate</td> </tr> <tr> <td>pm2803 3rd-axis rapid traverse rate</td> <td>pm2807 7th-axis rapid traverse rate</td> </tr> <tr> <td>pm2804 4th-axis rapid traverse rate</td> <td>pm2808 8th-axis rapid traverse rate</td> </tr> </table>	pm2801 1st-axis rapid traverse rate	pm2805 5th-axis rapid traverse rate	pm2802 2nd-axis rapid traverse rate	pm2806 6th-axis rapid traverse rate	pm2803 3rd-axis rapid traverse rate	pm2807 7th-axis rapid traverse rate	pm2804 4th-axis rapid traverse rate	pm2808 8th-axis rapid traverse rate																									
pm2801 1st-axis rapid traverse rate	pm2805 5th-axis rapid traverse rate																																	
pm2802 2nd-axis rapid traverse rate	pm2806 6th-axis rapid traverse rate																																	
pm2803 3rd-axis rapid traverse rate	pm2807 7th-axis rapid traverse rate																																	
pm2804 4th-axis rapid traverse rate	pm2808 8th-axis rapid traverse rate																																	
An axis interlock signal is entered,	<p>Jog is correct when:</p> <table border="0" data-bbox="367 1052 1097 1167"> <tr> <td>#3078 D₀ = 1 (1st-axis)</td> <td>#3078 D₄ = 1 (5th-axis)</td> </tr> <tr> <td>#3078 D₁ = 1 (2nd-axis)</td> <td>#3078 D₅ = 1 (6th-axis)</td> </tr> <tr> <td>#3078 D₂ = 1 (3rd-axis)</td> <td>#3078 D₆ = 1 (7th-axis)</td> </tr> <tr> <td>#3078 D₃ = 1 (4th-axis)</td> <td>#3078 D₇ = 1 (8th-axis)</td> </tr> </table> <p>When 0, the axis does not work.</p>	#3078 D ₀ = 1 (1st-axis)	#3078 D ₄ = 1 (5th-axis)	#3078 D ₁ = 1 (2nd-axis)	#3078 D ₅ = 1 (6th-axis)	#3078 D ₂ = 1 (3rd-axis)	#3078 D ₆ = 1 (7th-axis)	#3078 D ₃ = 1 (4th-axis)	#3078 D ₇ = 1 (8th-axis)	An axis interlock signal is entered for some reason. Refer to the manual of the machine manufacturer to release the axis interlock.																								
#3078 D ₀ = 1 (1st-axis)	#3078 D ₄ = 1 (5th-axis)																																	
#3078 D ₁ = 1 (2nd-axis)	#3078 D ₅ = 1 (6th-axis)																																	
#3078 D ₂ = 1 (3rd-axis)	#3078 D ₆ = 1 (7th-axis)																																	
#3078 D ₃ = 1 (4th-axis)	#3078 D ₇ = 1 (8th-axis)																																	
The machine is in LOC position	<p>I/O signal #3006 D₆ = 1. (In i80L multi-program system, pm3056, for second program and #3066 D₆ for third program.) Setting pm0000 D₁ = 1 (In i80L multi-program system, pm0024 D₁ = 1 for second program and pm0027 D₁ = 1 for third program.) Check machine lock switch input.</p>	Check switch. Check whether parameter pm0000 D ₁ is 1.																																

4.3.7 MANUAL ZERO RETURN OPERATION FAULTY

This chapter assumes that manual feed (JOG) and manual rapid traverse rate (RAPID) operate normally.

Table 4.36 Manual Zero Return Operation Faulty

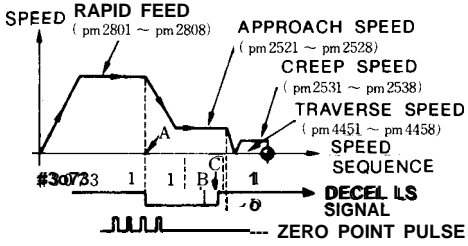
Cause of Trouble	Check Method	Solution
Mode not set to zero return	/O signal #3007 Do must be 1. (In i80L multi-program system, #3057 D ₀ for second program and #3067 D ₀ for third program.) characteristically, the signal runs to OT at the existing speed even when it has passed point A in the figure shown below.	Select the manual return-to-reference point mode or the relative switch. Check the wiring.
Rapid or jog mode not selected	n parallel with I/O signal #3007 D ₀ = 1, #3000 J ₀ or D ₁ must be 1. In i80L multi-program system, check #3050 for second program and #3060 for third program. Unless this condition is satisfied, the operation cannot start.	Use a sequence change, etc. to enable the manual return-to-reference point signal and JOG or RAPID signal to be input simultaneously.
Deceleration limit switch not input	 <p>Return to Reference Point Control I/O Signal: Confirm that I/O signals #3073 D₀ to D₇ change as above, transmitting I/O signals at a low speed such as jog, etc.</p>	Check the deceleration limit switch to check the wiring. If both the deceleration limit switch and wiring are normal, replace the model JANCD-FC800 board.
Parameter not set correctly	Referring to the above figure, verify the relative parameter with the attached parameter sheet.	If the parameter is different from the finally set value of the parameter sheet, reset it.
A dog position for the deceleration limit switch is arranged adequately.	occasionally dislocation may occur by one rotation of the motor.	Arrange the dog position to make the rising point (point C in the above figure) of the deceleration limit switch signal come to the center of points B through D of origin pulses [In i80M, I/O monitor #3610 (D ₆) to #3614 (D ₆). In i80L, I/O monitor #3620 (D ₂) to #3627 (D ₂).] of each axis, sending the signal in handle mode.
Others: •Coupling loose •Dog loose •Noise	This is a case in which the position is slipped at random. Shielded cable used for PG signal?	If loose, tighten. Check the shield processing and contact your YASKAWA representative.

a

4.3 TROUBLESHOOTING WITHOUT ALARM CODES (Cent'd)

4.3.8 CYCLE START FAILURE

Table 4.37 Cycle Start Failure

Cause of Trouble	Check Method	Solution
The cycle start signal is not input. The field hold is opened.	Is the parameter set to 1/0 signal #3003 D ₀ = 1 when the cycle start switch is depressed? In this case, the field hold signal must be opened. Normal at 1/0 signal #3003 D ₁ = 1. (In i80L multi-program system, #3053 D ₀ for cycle start and #3053 D ₁ for feed hold of second program, #3063 D ₀ for cycle start and #3063 D ₁ for feed hold of third program.)	Check the switch and wiring. If the machine interlock is working intermittently, refer to the manual of the machine manufacturer.
The start interlock signal is entered.	Normal at 1/0 signal #3004 D ₂ = 0. (In i80L multi-program system, #3054 D ₂ for second program and #3054 D ₂ for third program.)	If the machine interlock is working intermittently, refer to the manual of the machine manufacturer.
The machine is under resetting.	Normal at 1/0 signal #3500 D ₁ = 0. Confirm that the external reset input 1/0 signal #3004 D ₁ is also 0. (In i80L multi-program system, #3350 D ₁ for resetting and #3054 D ₁ for external reset input of second program. #3580 D ₁ for resetting and #3064 D ₁ for external reset input of third program.)	If the parameter is not set to 0 in several seconds, contact your YASKAWA representative.

4.3.9 OPERATION IS NOT AVAILABLE WITH GO1 , G02, OR G03

Table 4.38 Operation is not Available with GO1, G02, or G03

Cause of Trouble	Check Method	Solution																																																																																																																																																																																																											
Spindle rotation is checked during feeding every minute.	Check whether parameter pm1000 D ₇ is 1. [If 1, check spindle rotation (I/O signal #3111 D ₆).]	Rotate the spindle. For dry runs, set pm1000 D ₇ to 0 and do not check spindle rotation.																																																																																																																																																																																																											
Improper spindle speed	Check whether parameter pm1000 D ₇ = 1. [If 0, check spindle speed match (I/O signal #3111, for second spindle. #3121 D ₆).]	[If wiring is proper, JANCD-FC800 board or spindle drive unit may be defective. Contact your YASKAWA representative.																																																																																																																																																																																																											
Cutting feed override is set to 0%.	Check whether I/O signals #3040 D ₄ to D ₈ are set correctly.	<ul style="list-style-type: none"> • Turn override switch. If the wiring is faulty, correct it. • Check parameter setting. 																																																																																																																																																																																																											
In dry run state, manual jog feed speed is set correctly.	<table border="1"> <thead> <tr> <th colspan="5">I/O Signal #3040 D₄ ~ D₈</th> <th rowspan="2">Feed Override (automatic operation mode)</th> </tr> <tr> <th>Ov 16</th> <th>Ov 8</th> <th>Ov 4</th> <th>Ov 2</th> <th>0V 1</th> </tr> </thead> <tbody> <tr><td>0</td><td>0</td><td>0</td><td>0</td><td>0</td><td>0%</td></tr> <tr><td>0</td><td>0</td><td>0</td><td>0</td><td>1</td><td>10%</td></tr> <tr><td>0</td><td>0</td><td>0</td><td>1</td><td>0</td><td>20%</td></tr> <tr><td>0</td><td>0</td><td>0</td><td>1</td><td>1</td><td>30%</td></tr> <tr><td>0</td><td>0</td><td>1</td><td>0</td><td>0</td><td>40%</td></tr> <tr><td>0</td><td>0</td><td>1</td><td>0</td><td>1</td><td>50%</td></tr> <tr><td>0</td><td>0</td><td>1</td><td>1</td><td>0</td><td>60%</td></tr> <tr><td>0</td><td>0</td><td>1</td><td>1</td><td>1</td><td>70%</td></tr> <tr><td>0</td><td>1</td><td>0</td><td>0</td><td>0</td><td>80%</td></tr> <tr><td>0</td><td>1</td><td>0</td><td>0</td><td>1</td><td>90%</td></tr> <tr><td>0</td><td>1</td><td>0</td><td>1</td><td>0</td><td>100%</td></tr> <tr><td>0</td><td>1</td><td>0</td><td>1</td><td>1</td><td>110%</td></tr> <tr><td>0</td><td>1</td><td>1</td><td>0</td><td>0</td><td>120%</td></tr> <tr><td>0</td><td>1</td><td>1</td><td>0</td><td>1</td><td>130%</td></tr> <tr><td>0</td><td>1</td><td>1</td><td>1</td><td>0</td><td>140%</td></tr> <tr><td>0</td><td>1</td><td>1</td><td>1</td><td>1</td><td>150%</td></tr> <tr><td>1</td><td>0</td><td>0</td><td>0</td><td>0</td><td>160%</td></tr> <tr><td>1</td><td>0</td><td>0</td><td>0</td><td>1</td><td>170%</td></tr> <tr><td>1</td><td>0</td><td>0</td><td>1</td><td>0</td><td>180%</td></tr> <tr><td>1</td><td>0</td><td>0</td><td>1</td><td>1</td><td>190%</td></tr> <tr><td>1</td><td>0</td><td>1</td><td>0</td><td>0</td><td>200%</td></tr> <tr><td>1</td><td>0</td><td>1</td><td>0</td><td>1</td><td>220%</td></tr> <tr><td>1</td><td>0</td><td>1</td><td>1</td><td>0</td><td>240%</td></tr> <tr><td>1</td><td>0</td><td>1</td><td>1</td><td>1</td><td>260%</td></tr> <tr><td>1</td><td>1</td><td>0</td><td>0</td><td>0</td><td>280%</td></tr> <tr><td>1</td><td>1</td><td>0</td><td>0</td><td>1</td><td>300%</td></tr> <tr><td>1</td><td>1</td><td>0</td><td>1</td><td>0</td><td>340%</td></tr> <tr><td>1</td><td>1</td><td>0</td><td>1</td><td>1</td><td>380%</td></tr> <tr><td>1</td><td>1</td><td>1</td><td>0</td><td>0</td><td>420%</td></tr> <tr><td>1</td><td>1</td><td>1</td><td>0</td><td>1</td><td>460%</td></tr> <tr><td>1</td><td>1</td><td>1</td><td>1</td><td>0</td><td>500%</td></tr> <tr><td>1</td><td>1</td><td>1</td><td>1</td><td>1</td><td>540%</td></tr> </tbody> </table>		I/O Signal #3040 D ₄ ~ D ₈					Feed Override (automatic operation mode)	Ov 16	Ov 8	Ov 4	Ov 2	0V 1	0	0	0	0	0	0%	0	0	0	0	1	10%	0	0	0	1	0	20%	0	0	0	1	1	30%	0	0	1	0	0	40%	0	0	1	0	1	50%	0	0	1	1	0	60%	0	0	1	1	1	70%	0	1	0	0	0	80%	0	1	0	0	1	90%	0	1	0	1	0	100%	0	1	0	1	1	110%	0	1	1	0	0	120%	0	1	1	0	1	130%	0	1	1	1	0	140%	0	1	1	1	1	150%	1	0	0	0	0	160%	1	0	0	0	1	170%	1	0	0	1	0	180%	1	0	0	1	1	190%	1	0	1	0	0	200%	1	0	1	0	1	220%	1	0	1	1	0	240%	1	0	1	1	1	260%	1	1	0	0	0	280%	1	1	0	0	1	300%	1	1	0	1	0	340%	1	1	0	1	1	380%	1	1	1	0	0	420%	1	1	1	0	1	460%	1	1	1	1	0	500%	1	1	1	1	1	540%
	I/O Signal #3040 D ₄ ~ D ₈					Feed Override (automatic operation mode)																																																																																																																																																																																																							
	Ov 16	Ov 8	Ov 4	Ov 2	0V 1																																																																																																																																																																																																								
	0	0	0	0	0	0%																																																																																																																																																																																																							
	0	0	0	0	1	10%																																																																																																																																																																																																							
	0	0	0	1	0	20%																																																																																																																																																																																																							
	0	0	0	1	1	30%																																																																																																																																																																																																							
	0	0	1	0	0	40%																																																																																																																																																																																																							
	0	0	1	0	1	50%																																																																																																																																																																																																							
	0	0	1	1	0	60%																																																																																																																																																																																																							
	0	0	1	1	1	70%																																																																																																																																																																																																							
	0	1	0	0	0	80%																																																																																																																																																																																																							
	0	1	0	0	1	90%																																																																																																																																																																																																							
	0	1	0	1	0	100%																																																																																																																																																																																																							
	0	1	0	1	1	110%																																																																																																																																																																																																							
	0	1	1	0	0	120%																																																																																																																																																																																																							
	0	1	1	0	1	130%																																																																																																																																																																																																							
	0	1	1	1	0	140%																																																																																																																																																																																																							
	0	1	1	1	1	150%																																																																																																																																																																																																							
	1	0	0	0	0	160%																																																																																																																																																																																																							
	1	0	0	0	1	170%																																																																																																																																																																																																							
	1	0	0	1	0	180%																																																																																																																																																																																																							
	1	0	0	1	1	190%																																																																																																																																																																																																							
	1	0	1	0	0	200%																																																																																																																																																																																																							
	1	0	1	0	1	220%																																																																																																																																																																																																							
	1	0	1	1	0	240%																																																																																																																																																																																																							
	1	0	1	1	1	260%																																																																																																																																																																																																							
1	1	0	0	0	280%																																																																																																																																																																																																								
1	1	0	0	1	300%																																																																																																																																																																																																								
1	1	0	1	0	340%																																																																																																																																																																																																								
1	1	0	1	1	380%																																																																																																																																																																																																								
1	1	1	0	0	420%																																																																																																																																																																																																								
1	1	1	0	1	460%																																																																																																																																																																																																								
1	1	1	1	0	500%																																																																																																																																																																																																								
1	1	1	1	1	540%																																																																																																																																																																																																								
Start interlock signal input.	Check whether I/O signal #3004 D ₁ is 1. (Normal if it is 0.)	Release the interlock with reference to instruction.																																																																																																																																																																																																											
Axis-interlock is input	Check whether I/O signals #3078 (D ₀ to D ₄) are 0. (Not interlocked if they are 1.)	Release the interlock with reference to instruction.																																																																																																																																																																																																											
Servo system setting is erroneous.	Is manual feeding enabled? (Check whether the machine operates in manual mode.)	See Par. 4.3.7.																																																																																																																																																																																																											

4

4.3 TROUBLESHOOTING WITHOUT ALARM CODES (Cent'd)

4.3.10 SPINDLE DOES NOT ROTATE

Table 4.39 Spindle Does Not Rotate

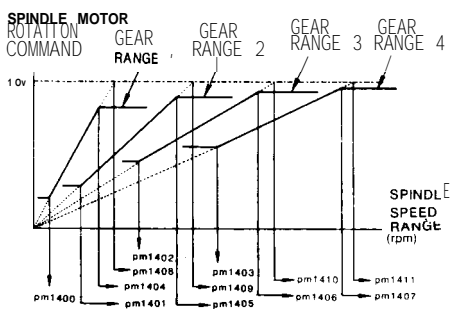
Cause of Trouble	Check Method	Solution																				
Program error •S command is missing. •Start M code is missing. (M03, M04, etc.)	Check on the RUN screen 	Correct the program.																				
The start signal is not issued.	Check output signals (#1100 level) on the I/O signal screen.	Release interlock with reference to the manual issued by the machine manufacturer.																				
Spindle rotation command is not issued.	Check spindle voltage with spindle unit.	Correct the wiring and sequence so that command voltage develops at the spindle unit.																				
S5-digit specification	Check #3654 to #3656 (in multiple spindle system #3664-3666 for second spindle, #3674-676 for third spindle, and #3684-3686 for fourth spindle) on the I/O signal screen.																					
Spindle drive is in alarm state.	Check alarm indication of spindle drive unit.	Remove the cause of alarm of spindle drive unit.																				
Erroneous combination of GRO and SOR. O is entered to parameters #1412 and #1413.	Check I/O signal #3110 (in multiple spindle system #3120 for second spindle, #3130 for third spindle, and #3140 for fourth spindle) according to the table below. GRO, SOR Input And S4-digit Command Analog Voltage	This combination causes command voltage of OV, and the spindle does not rotate. When O is set, the spindle does not rotate. Set correct values in parameter pm1412 (pm1432, pm1452, pm1472) and pm1413 (pm1433, pm1453, pm1473).																				
	<table border="1"> <thead> <tr> <th colspan="2">I/O Signal #3110 (#3120, #3130, #3140)</th> <th rowspan="2">S4-digit Command Analog Voltage Value</th> </tr> <tr> <th>D₇</th> <th>D₆</th> </tr> </thead> <tbody> <tr> <td>GRO Input</td> <td>SOR Input</td> <td></td> </tr> <tr> <td>0</td> <td>0</td> <td>Voltage corresponding to spindle speed range specified in NC program</td> </tr> <tr> <td>0</td> <td>1</td> <td>Voltage corresponding to parameter pm1412 (pm1432, pm1452, pm1472)</td> </tr> <tr> <td>1</td> <td>0</td> <td>Parameter pm1413 (pm1433, pm1453, pm1473) setting value</td> </tr> <tr> <td>1</td> <td>1</td> <td>OV</td> </tr> </tbody> </table>		I/O Signal #3110 (#3120, #3130, #3140)		S4-digit Command Analog Voltage Value	D ₇	D ₆	GRO Input	SOR Input		0	0	Voltage corresponding to spindle speed range specified in NC program	0	1	Voltage corresponding to parameter pm1412 (pm1432, pm1452, pm1472)	1	0	Parameter pm1413 (pm1433, pm1453, pm1473) setting value	1	1	OV
	I/O Signal #3110 (#3120, #3130, #3140)		S4-digit Command Analog Voltage Value																			
	D ₇			D ₆																		
	GRO Input		SOR Input																			
	0		0	Voltage corresponding to spindle speed range specified in NC program																		
0	1	Voltage corresponding to parameter pm1412 (pm1432, pm1452, pm1472)																				
1	0	Parameter pm1413 (pm1433, pm1453, pm1473) setting value																				
1	1	OV																				
Note 1. 0: Contact open 1: Contact closed 2. Note that setting parameter SSTOP (pm1000 D ₁) to 1 causes SSTOP to be input reversely.																						
<table border="1"> <tbody> <tr> <td>#3110 D₀</td> <td>GR1</td> </tr> <tr> <td>#3110 D₁</td> <td>GR2</td> </tr> <tr> <td>#3110 D₂</td> <td>GR3</td> </tr> <tr> <td>#3110 D₃</td> <td>GR4</td> </tr> </tbody> </table>	#3110 D ₀	GR1	#3110 D ₁	GR2	#3110 D ₂	GR3	#3110 D ₃	GR4														
#3110 D ₀	GR1																					
#3110 D ₁	GR2																					
#3110 D ₂	GR3																					
#3110 D ₃	GR4																					
(2nd-spindle #3120, 3rd-spindle #3130. 4th-spindle #3140)		Correct parameters.																				

4.3.11 9" CRT SCREEN IS DARK

Table 4.40 9" CRT Screen is Dark

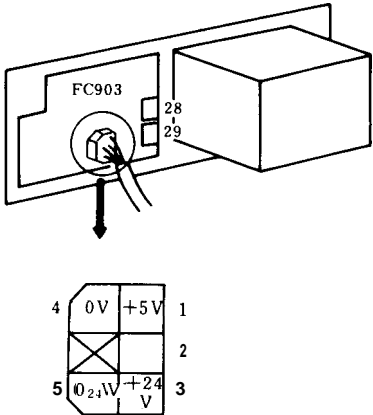
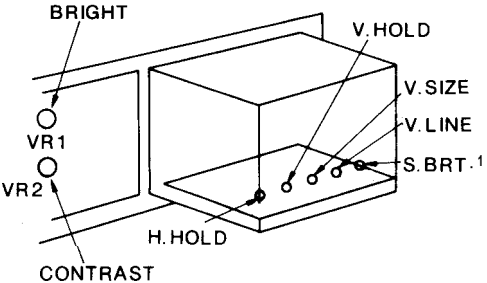
Cause of Trouble	Check Method	Solution												
<p>Power voltage is too low.</p>	<p>Check it with CN13 on the model JANCD-FC900B board or CN28 on the model JANCD-FC903 board at rear side of 9" CRT unit.</p>  <table border="1" data-bbox="553 869 695 1003"> <tr> <td>4</td> <td>0V</td> <td>+5V</td> <td>1</td> </tr> <tr> <td></td> <td></td> <td></td> <td>2</td> </tr> <tr> <td>5</td> <td>0.24V</td> <td>+24V</td> <td>3</td> </tr> </table> <p>CN 13 (Model JANCD-FC900B board) CN 28 (Model JANCD-FC903 board)</p>	4	0V	+5V	1				2	5	0.24V	+24V	3	<ul style="list-style-type: none"> • If the voltage drops at power cable, replace the cable. • If model CPS-12N or CPS-16F output voltage is also low, it may be caused by failure of model CPS-12N or CPS-16F. <p>Contact your YASKAWA representative.</p>
4	0V	+5V	1											
			2											
5	0.24V	+24V	3											
<p>Escutcheon is dirty.</p>	<p>Check visually if the surface of escutcheon and the section between escutcheon and CRT are dirty.</p>	<p>Clean up CRT display and escutcheon.</p>												
<p>Brightness is not properly adjusted.</p>		<p>[Do not perform setup change of CRT as a rule.] Perform adjustment with VR1 (BRIGHT) on model JANCD-FC900B board.</p>												
<p>Hardware failure</p>	<p>{Trouble other than above}</p>	<p>Replace CRT unit or model JANCD-FC900B board. Contact your YASKAWA representative.</p>												

4

4.3 TROUBLESHOOTING WITHOUT ALARM CODES (Cent'd)

4.3.12 EDIT DOES NOT FUNCTION

Table 4.41 Edit Does Not Function

Cause of Trouble	Check Method	Solution
<p>Erroneous input signal</p> <p>(a) The edit lock signal is entered.</p> <p>(b) The setting edit 10cI signal is entered.</p>	<p>Lock at I/O signal pm3007 D₂ = 1.</p> <p>Lock at setting pm0000 D₇ = 1.</p>	<p>Select the edit lock release. Set setting pm0000 D₇ to 0. For the procedure, refer to YASNAC i80M Instruction Manual (TOE-C843-11.30) and YASNAC i80L Instruction Manual (TOE-C843-11.20).</p>
<p>A parameter to lock a specially numbered program is turned on.</p>		<p>This is a setting to prevent programs from being destroyed by erroneous edit operation. For modification of parameters, refer to YASNAC i80M Instruction Manual (TOE-C843-11.30) and YASNAC i80L Instruction Manual (TOE-C843-11.20).</p>
<p>Others:</p> <p>(a) Memory capacity exceeded</p> <p>(b) Stored program volume exceeded</p> <p>(c) Overlapped stored program number:</p>	<p>MEMORY OVER!</p> <p>PROGRAM OVER!</p> <p>ALREADY IN!</p> <p>A warning alarm is issued for each.</p>	<p>• Refer to YASNAC i80M Instruction Manual (TOE-C843-11.30) and "Part Program Editing" of the YASNAC i80L Instruction Manual (TOE-C843-11.20).</p> <p>• Continue the edit operation after erasing unnecessary programs.</p>

4.3.13 FIN WAIT OCCURS BY SPINDLE RELATED INSTRUCTION

The sequential processing entered some signal wait mode and was then discontinued.

Table 4.42 Fin Wait occurs by Spindle Related Instruction

Cause of Trouble	Check Method	Solution
A signal identical with the spindle speed is not entered.	If this trouble occurs at the time of command issuing such as "M03 S100", etc., confirm I/O signal pm3111D ₆ = 1 (pm3121D ₆ for 2nd-spindle). Refer to the circuit diagram of the machine manufacturer to confirm I/O input section I/O signal #1000 level.	If no trouble is found in the wiring, there is a possibility of a fault model JAN CD-FC800 board or fault spindle drive unit. Contact your YASKAWA representative.
The axis zero speed signal is not entered.	If this trouble occurs at stop time "M05", refer to the circuit diagram of the machine manufacturer to confirm I/O input section I/O signal #1000 level.	If no trouble is found in the wiring, there is a possibility of a fault model JANCD-FC800 board or fault spindle drive unit.
Other	If this trouble occurs at the time of "M19" or "M20", spindle orientation command, refer to the circuit diagram of the machine manufacturer to confirm the I/O, especially the orientation-related sections.	If no trouble is found in the wiring, there is a possibility of a fault model JANCD-FC800 board or fault spindle drive unit. Contact your YASKAWA representative.

4

4.3 TROUBLESHOOTING WITHOUT ALARM CODES (Cent'd)

4.3.14 SKIP FUNCTION (G31) OPERATION FAILURE

Table 4.43 Skip Function (G31) Operation Failure

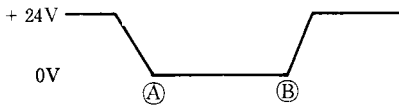
Cause of Trouble	Check Method	Solution
Input failure of skip signal	Use I/O signal #3514 D ₀ to D ₂ to confirm the skip signal ON/OFF.	Confirm operation of the contactless switches, etc.
Model JANCD-FC230B or FC260 board is wrong.	Refer to YASNAC i80 Connecting Manual (TOE-C843-11.5).	Replace model JANCD-FC230B or FC260 board. Contact your YASKAWA representative.
Parameter not set correctly	<p>Parameter pm2001 D₀</p> <p>D₀ 1: Use a transmission speed shown at the skip function (G31) command time as a speed set to parameter pm2440.</p> <p>O: Use a transmission speed shown at the skip function (G31) command time as a speed assigned by the F code.</p> <p>For example, the machine does not work when the transmission speed is O at the parameter pm2440 G31 command time.</p> <p>Parameter pm5011 D₀ to D₂</p> <p>Set a signal mode shown at the start time of the "SKIP" input for the D₀ skip function,</p>  <p>Ⓐ : When this parameter is set to "O", start the operation at the time of change from 24 V to 0 V.</p> <p>Ⓑ : When this parameter is set to "I", start the operation at the time of change from 0 V to 24 V.</p> <p>Note When this parameter is changed, turn power on, then off again.</p> <p>Parameter pm5010 D₀ to D₂</p> <p>Determine ENABLE/DISABLE of an input control circuit of "SKIP" for the skip function.</p> <ol style="list-style-type: none"> When the skip function is used, set the bit to "I". When this parameter is changed, turn power on, then off again. 	Set the relevant parameters correctly.

4.3.15 TAPE MODE DOES NOT FUNCTION

Table 4.44 Tape Mode Does Not Function

Cause of Trouble	Check Method	Solution																																																																																																																				
Failure of input signal. Mode input is not correct.	/O signal #3000D ₄ should be 1 and #3000D ₀ to D ₃ and D ₅ to D ₇ should be 0. (TAPE should appear on CRT screen.) In i80L multi-program system, #3050 for second program and #3060 for third program.)																																																																																																																					
TAPE mode does not start,	See Par. 4.3.8, "CYCLE START FAILURE".																																																																																																																					
Parameter failures such as baud rate, stop bit, and control code	See Par. 4.2.3, "ALARMS 0016, 0017, 0018, 9016, 9017 AND 9018 (RS-232C ERROR)" .																																																																																																																					
Tape reader setting failure	<table border="1"> <thead> <tr> <th colspan="6">DIP Switch</th> <th rowspan="2">Read Speed char/s</th> <th rowspan="2">Transmission Baud Rate</th> <th rowspan="2">AUTO Self-Checking</th> <th rowspan="2">Input Control</th> </tr> <tr> <th colspan="2">For PTR Speed</th> <th colspan="2">For Transmission Rate</th> <th>Input Control Selection</th> <th>For Self-Checking</th> </tr> <tr> <th>S1</th> <th>S2</th> <th>B1</th> <th>B2</th> <th>C/L</th> <th>STS</th> <th></th> <th></th> <th></th> <th></th> </tr> </thead> <tbody> <tr> <td>*ON</td> <td>OFF</td> <td>OFF</td> <td>OFF</td> <td>ON</td> <td>OFF</td> <td>270</td> <td>4800</td> <td>AUTO</td> <td></td> </tr> <tr> <td>ON</td> <td>ON</td> <td></td> <td></td> <td></td> <td>OFF</td> <td>300</td> <td></td> <td>AUTO</td> <td></td> </tr> <tr> <td>OFF</td> <td>OFF</td> <td></td> <td></td> <td></td> <td>OFF</td> <td>200</td> <td></td> <td>AUTO</td> <td></td> </tr> <tr> <td></td> <td></td> <td>ON</td> <td>ON</td> <td></td> <td>OFF</td> <td></td> <td>5600</td> <td>AUTO</td> <td></td> </tr> <tr> <td></td> <td></td> <td>ON</td> <td>OFF</td> <td></td> <td>OFF</td> <td></td> <td>2400</td> <td>AUTO</td> <td></td> </tr> <tr> <td></td> <td></td> <td>OFF</td> <td>OFF</td> <td></td> <td>OFF</td> <td></td> <td>1200</td> <td>AUTO</td> <td></td> </tr> <tr> <td></td> <td></td> <td></td> <td></td> <td></td> <td>ON</td> <td></td> <td></td> <td>Self-checking</td> <td></td> </tr> <tr> <td></td> <td></td> <td></td> <td></td> <td>ON</td> <td></td> <td></td> <td></td> <td></td> <td>Code control</td> </tr> <tr> <td></td> <td></td> <td></td> <td></td> <td>OFF</td> <td></td> <td></td> <td></td> <td></td> <td>Line control</td> </tr> </tbody> </table> <p>* Standard setting</p> <p>(DIP switch arrangement) . standard setting</p> <p>Setting of Tape Reader</p>	DIP Switch						Read Speed char/s	Transmission Baud Rate	AUTO Self-Checking	Input Control	For PTR Speed		For Transmission Rate		Input Control Selection	For Self-Checking	S1	S2	B1	B2	C/L	STS					*ON	OFF	OFF	OFF	ON	OFF	270	4800	AUTO		ON	ON				OFF	300		AUTO		OFF	OFF				OFF	200		AUTO				ON	ON		OFF		5600	AUTO				ON	OFF		OFF		2400	AUTO				OFF	OFF		OFF		1200	AUTO							ON			Self-checking						ON					Code control					OFF					Line control	Check setting status of tape reader Model 2801 B-2 according to the table on the left and set it correctly again.
DIP Switch						Read Speed char/s	Transmission Baud Rate					AUTO Self-Checking	Input Control																																																																																																									
For PTR Speed		For Transmission Rate		Input Control Selection	For Self-Checking																																																																																																																	
S1	S2	B1	B2	C/L	STS																																																																																																																	
*ON	OFF	OFF	OFF	ON	OFF	270	4800	AUTO																																																																																																														
ON	ON				OFF	300		AUTO																																																																																																														
OFF	OFF				OFF	200		AUTO																																																																																																														
		ON	ON		OFF		5600	AUTO																																																																																																														
		ON	OFF		OFF		2400	AUTO																																																																																																														
		OFF	OFF		OFF		1200	AUTO																																																																																																														
					ON			Self-checking																																																																																																														
				ON					Code control																																																																																																													
				OFF					Line control																																																																																																													
Connection failure	<ul style="list-style-type: none"> Check the wiring status of RS-232C cable according to the YASNAC i80 Connecting Manual (TOE -C843-11.5). Check loosening and removal of connector. 	Correct connection. Plug in the connector again.																																																																																																																				
Failure of tape reader	<ul style="list-style-type: none"> Depressing the switch for feeding tape does not cause the tape to be moved." LED (red) of the tape reader is off. <ol style="list-style-type: none"> Power to the tape reader is off. The tape reader itself is defective. 	Replace the tape reader. Replace the model JANCD-FC200 board or failed cable tape reader.																																																																																																																				
Other	Check the tape retainer again.																																																																																																																					
Failure of tape reader power (EYG 300/55 GTL)	<ul style="list-style-type: none"> Check that input voltage 200 V is supplied. Check that output voltage is 5 V or 24 V. 																																																																																																																					

4

4.4 POWER SUPPLY VOLTAGE CHECK

4.4.1 CHECK AT POWER SUPPLY VOLTAGE

The voltage between terminals CN05-1 and CN05-5 in the power supply unit (model CPS-12N or model CPS-16F) should be within 200/220VAC +15% (170 to 253VAC) at 50/60Hz +2 Hz.

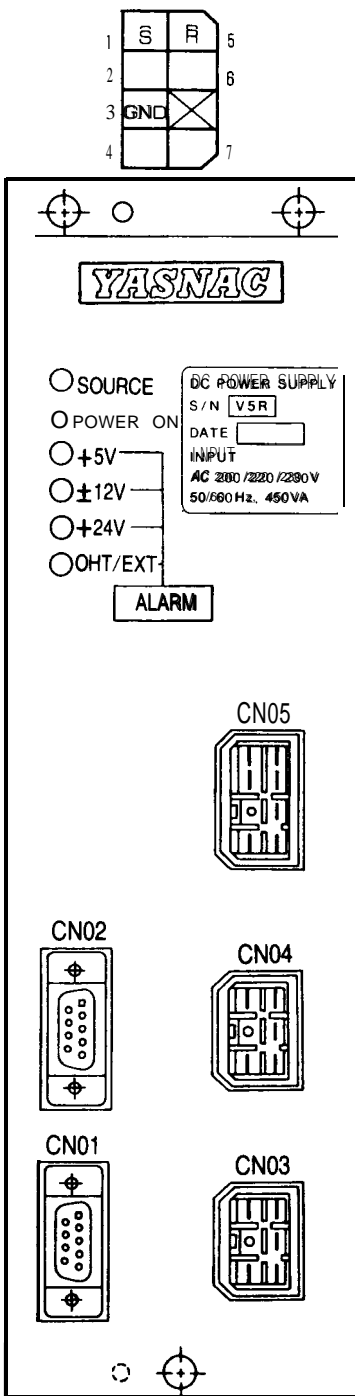

Fig. 4.9 External View of Power Supply Unit
Model CPS-16F

4.4.2 INDICATION OF LAMP OF POWER SUPPLY UNIT

Table 4.45 Indication Lamp

Indication	Color	Meaning
SOURCE	Green	With this lamp on, AC input is executed or DC high voltage will still be applied even if AC input OFF.
POWER ON	Green	Power on with normal DC output.
+5 V	Red	+5 V fault output
±12 V	Red	±12 V fault output
+24 v	Red	+24 V fault output
EXT. ALARM	Red	Alarm input from external power supply etc. is ON.

4.4.3 CHECK DC POWER SUPPLY VOLTAGE

Measure at CN03 of model CPS-12N or model CPS-16F.

4

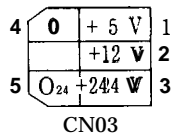

- +5 V : Measure CN03 1-4
- +12 V : Measure CN03 2-4
- +24 V : Measure CN03 3-5

4.5 STATUS DISPLAY BY SELF-DIAGNOSIS FUNCTION (DGN)

When the I/O section of the NC unit is suspected of failure, diagnostic numbers can be keyed-in on the NC control panel to display and check I/O signals for status.

4.5.1 OUTLINE OF DISPLAY

Table 4.46 Diagnostic Nos. and Contents

Diagnostic No.	Display Contents	Remarks
#1000 to #1077	Input signals for machine tool	Refer to machine manufacturer's manual.
#1100 to #1175	Output signals to machine tool	
#3500 to #3659	Output signals to power sequence (PLC) (standard output signal)	Refer to Appendix of YASNAC i80M Instruction Manual (TOE-C843-11.31) or Appendix of YASNAC i80L Instruction Manual (TOE-C843-11.21). For details of signals, refer to YASNAC i80 Connecting Manual (TOE-C843-11.5).
#3000 to #3119	Input signals to power sequence (PLC) (standard output signal)	

Note

1. With a power sequence (PC) setup built-in, the meanings of signals #1000 to #1077 and #1100 to #1175 depend on each power sequence program. Read the machine manufacturer's manual.

	D ₇	D ₆	D ₅	D ₄	D ₃	D ₂	D ₁	D ₀
Display :	0	0	0	0	1	1	1	1
	└─ Contact opened				└─ Contact closed			

2. For keep memory, refer to Section. 8, " OPERATIONS OF FIXED FILES".

4.5.2 DISPLAYING INPUT/OUTPUT SIGNALS

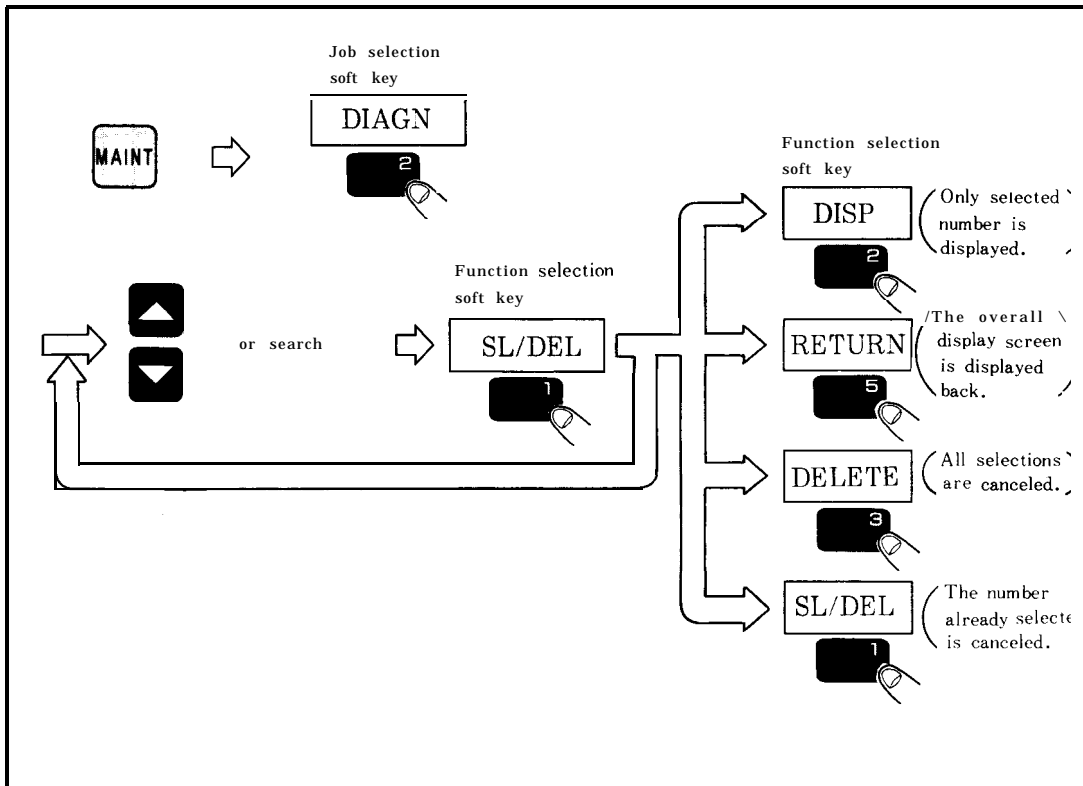

4

□ Depress the **MAINT** key.

□ Depress the **IN/OUT** job selection key.

– On/Off status of 1/0 signal can be displayed.

Note The status of 1/0 signal can be displayed at all times, including during automatic operation.

4.5 STATUS DISPLAY BY SELF-DIAGNOSIS FUNCTION (DGN) (Cent'd)

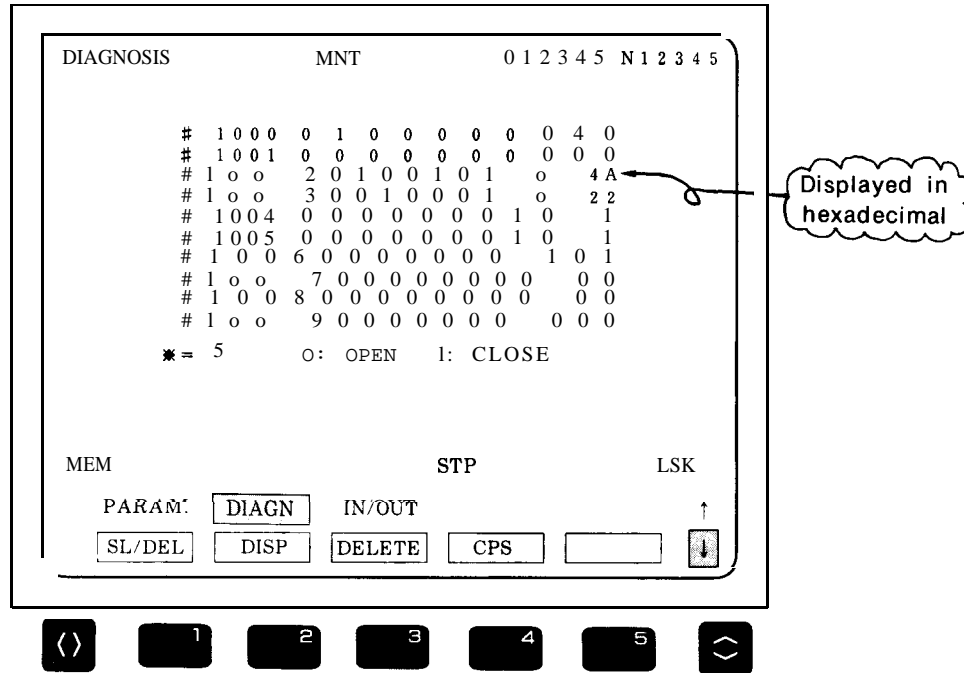



Fig. 4.10 I/O Monitor Display Screen

Note

1. For details of this display, refer to Par. 4.6.3 of YASNAC i80M Instruction Manual (TOE-C843-11.30) and APPENDIX "STANDARD I/O DIAGNOSTIC CODES" of YASNAC i80M Instruction Manual (TOE-C843-11.31).
2. Numeric values at the right end of the I/O monitor display screen are displayed in hexadecimal for convenience of maintenance.

• Procedure for Displaying I/O Signals

- 3** This unit permits any number to be selected to display I/O signals.

First, depress the  key to move the cursor to a desired number, or search for a desired number to move the cursor that number.

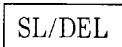

-  Depress the  function selection soft key, and "*" and the number of selected numbers will be displayed.



- 5** Select the numbers to be displayed by repeating steps **3** and .

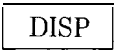

Note Up to 10 numbers can be selected.

4

6

(a) Depress the  function selection soft key,  and only a selected number will be displayed.

(b) Depressing the  function selection soft key  returns control to the overall display screen .

(c) Depressing the  function selection soft key  cancels all selections.

(d) Moving the cursor to the number already selected and depressing the  function selection soft key cancels selection of that number only.

4.5 STATUS DISPLAY BY SELF-DIAGNOSIS FUNCTION (DGN) (Cent'd)

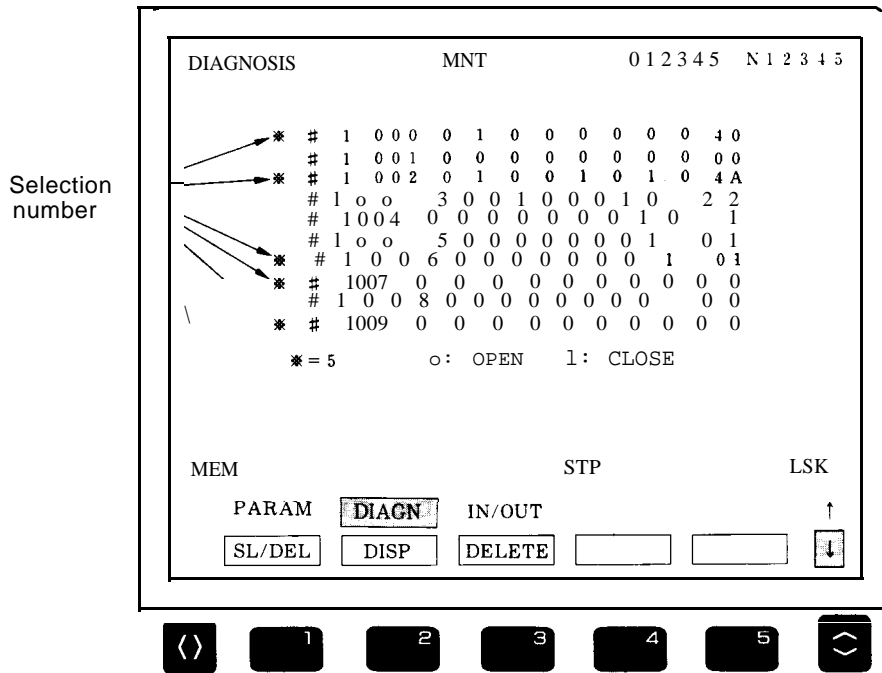

Fig. 4.11 I/O Display Screen

Depressing the **DISP** function selection soft key causes the following screen to be displayed.

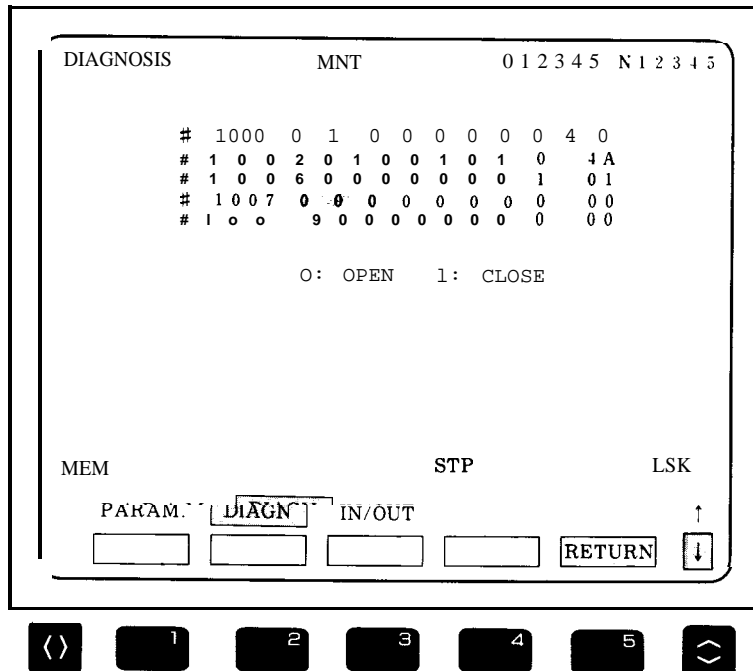

Fig. 4.12 Selection Display Screen

5. ADJUSTMENTS UPON INSTALLATION

This section explains adjustment procedures at YASNAC i80 installation.

CONTENTS

5. ADJUSTMENTS UPON INSTALLATION 135

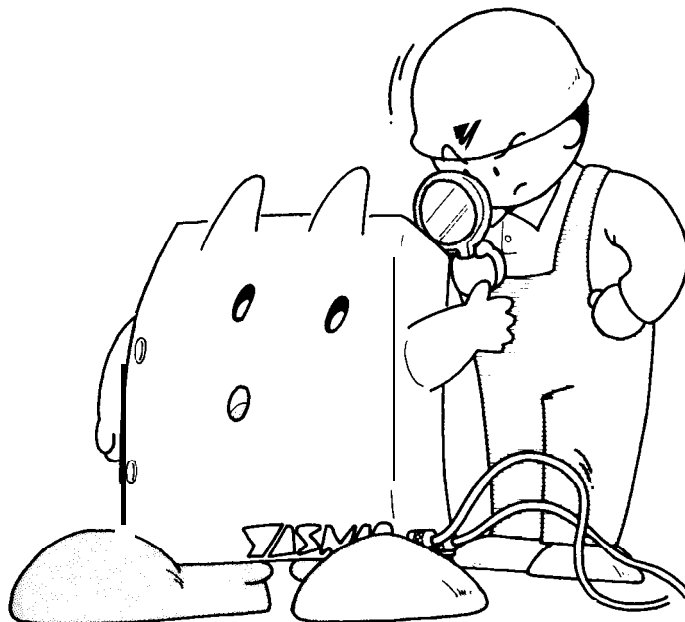

5. ADJUSTMENTS UPON INSTALLATION (Cent'd)

Upon installation , make adjustments in reference to the adjustment procedures given. in the table below.

Table 5.1 Adjustment Procedures

No.	Procedure	Remarks
1	Check the interior and exterior of the control cabinet.	
2	Check screw terminals for tightness.	
3	Connect external cables and check.	
4	Connect the power input cable.	
5	Check connector and module locations to be sure of positive connections.	
6	Check settings.	
7	Check input power supply voltage and frequency.	
8	Check that the composite power supply unit outputs are not short-circuited.	
9	Check the output voltages after initially applying power.	
10	Check the I/O signals between the NC unit and the machine tool.	
11	Check parameters and setting data.	
12	Perform a second power application.	
13	Check to be sure the emergency stop functions.	
14	Check movement on each axis by manual feed.	
15	Adjust the servo system.	
16	Check that all NC functions operate successfully.	

(1) **Check the Interior and Exterior of the Control Cabinet.**

- .Check the control panel exterior for contamination and/or damage.
- Check the module connections inside the cabinet for tightness.
- .Check the cables and lead bundle inside the cabinet for damage.



(2) **Check Screw Terminals for Tightness.**

- Power input unit terminal block
- .Power on /off pushbutton switches on MDI and CRT unit.
- Control power transformer terminal block
- Check each terminal block cover, if any, for dislocation.

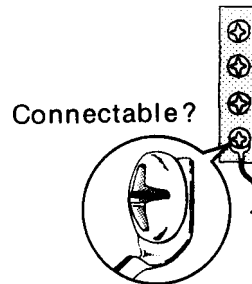

5

(3) **Connect External Cables.**

- .Check that the cable shield is connected to the ground block through a clamp.
- .Check that a protective ground wire is installed between the NC and the machine tool.
- .Check that the protective ground wire is of a **one-point** ground type.

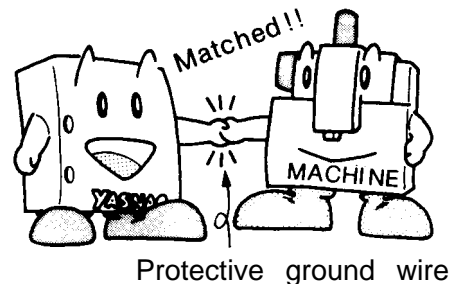

5. ADJUSTMENTS UPON INSTALLATION (Cent'd)

(4) Connect the Power Input Cable.

Before connecting the power input cable, verify that power input terminals R, S, and T inside the unit are not shorted.

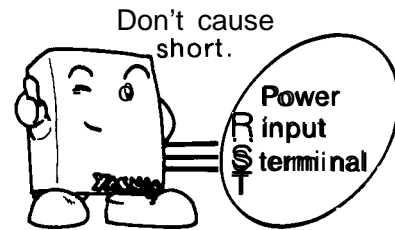

(5) Check Connector and Module Locations and Insertions.

- Check that the screws on the module clamps are tightened on the CPU rack.
- Check that the clamp claws on Honda connectors are tightened and that clamp screws are securely in place.
- Check that the clamp claws on power supply connectors are in place.
- Check that the clamp claws on flat cables are in place.

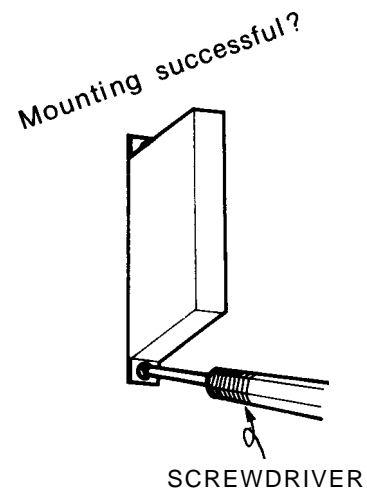

(6) Check Setting.

Verify the control power transformer setting in reference to the input power supply voltage.

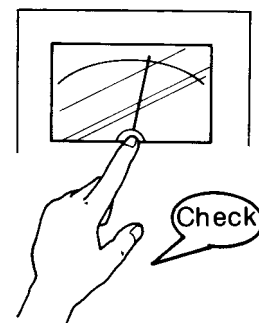

(7) Check Input Power Supply Voltage and Frequency.

- Check that the power supply voltage and frequency meet ratings.
- Check that the input power supply capacity is high enough for power consumption of the control unit,

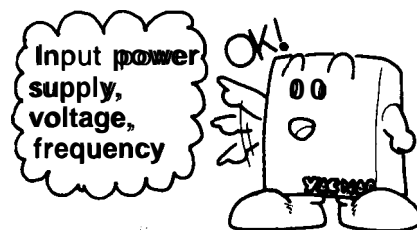

(8) Check That the Composite Power Supply Unit Outputs are not Short-Circuited.

Check for short-circuits between:

- . +5V and 0V
- . +12V and 0V
- . +24V and 0V
- .-12V and 0V

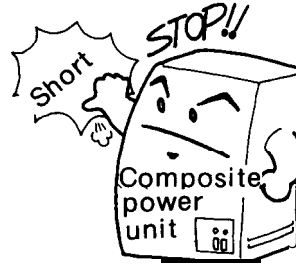

(9) Check the Output Voltage After Initially Applying Power.

Depress the POWER ON  pushbutton for first power application.

- Check that the air flow from the cooling air exhaust port is normal.
- Verify the output voltage of the composite power supply unit.

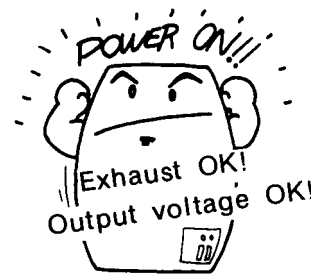

5

Rated Output	Output Voltage Range
+5 V	4.75 to 5.25 V
+12 V	11.87 to 13.12 V
-12 V	-11.87 to -13.12 V
+24 V	20.4 to 27.6 V

(10) Check the I/O Signals Between the NC and the Machine Tool.

- Check that I/O signals according to the list of I/O signals.

Check I/O signals.

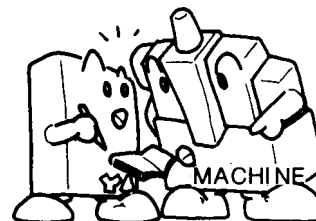

5. ADJUSTMENTS UPON INSTALLATION (Cent'd)

(11) Check Parameters and Setting Data.

Conduct checkups according to parameter numbers and setting data contents.

PARAMETER				DATA				
#	1	2	3	4	5	6	7	8
.
.
.
.

OK?

(12) Perform a Second Power Application.

Depress the POWER-ON pushbutton again for a second power application.



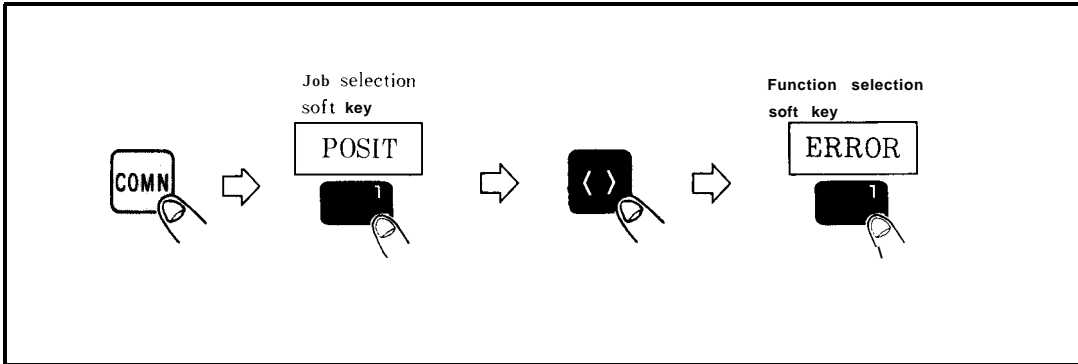

- .An alarm, if displayed, should be dealt with according to the list of alarms.
- .Check that each axis can be placed under servo clamp. For error pulse display for checking of servo clamp, perform the following operations:



Depress the  key.

Note This key is a shared screen display key. It is used to temporarily obtain another display during a process (e. g., stepping).

Depress the  job selection soft key.

Move the cursor downward by using  key and depress the  function selection soft key.

The error pulse screen is displayed.

5

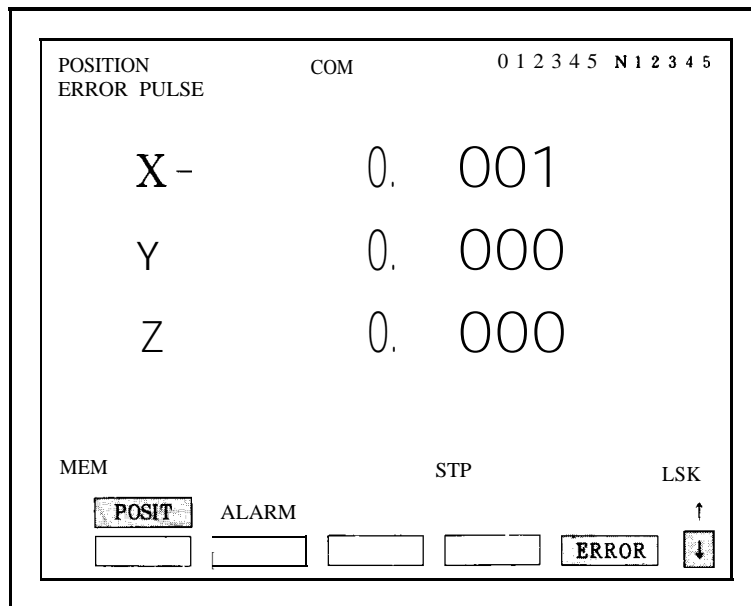
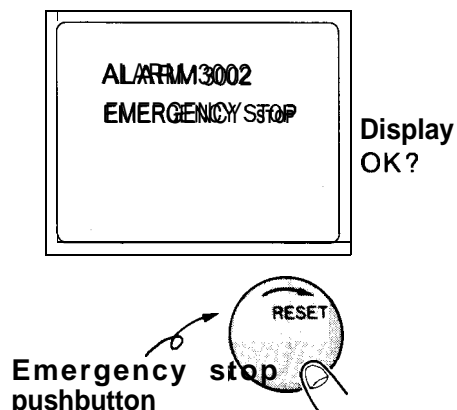

Fig. 5.1 Error Pulse Display Screen

5. ADJUSTMENTS UPON INSTALLATION (Cent'd)

(13) Verify the Emergency Stop.

With emergency stop activated (e.g. , by emergency stop pushbutton, machine end LS) , check that the second power supply (servo power supply) is turned off and that the alarm display " 3002: EMERGENCY STOP" appears.



(14) Check Movement on Each Axis by Manual Feed.

- Check that the machine tool properly follows up on the movement made by handle or step feed.
- Also operate the machine by manual jog feed. Activate its OT limit switch intentionally, and check to see that the machine is stopped by detection of an **over-travel** alarm.
- Check that the machine tool follows in the entire feed rate range in manual jog and rapid traverse rate.

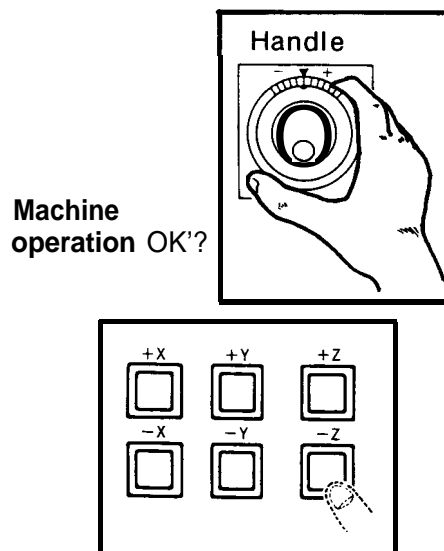

(15) Adjust the Servo System.

(16) Check That all NC Functions Activate Successfully.

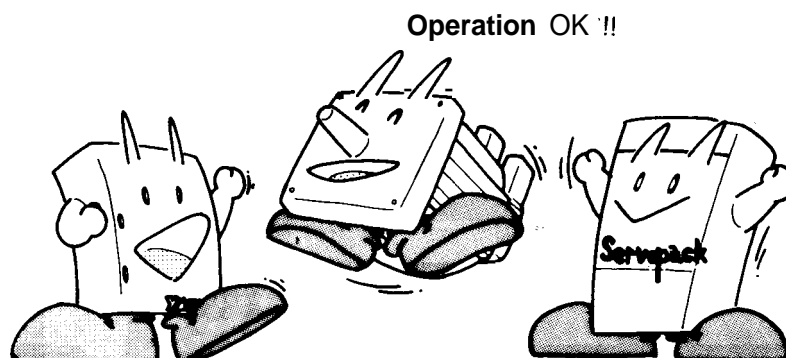

6. MODULE/UNIT REPLACEMENT PROCEDURE

This section explains the procedures for replacing modules and units.
The procedures for replacing modules and units in the NC rack and control panel should be understood fully for correct replacement.

CONTENTS

6. MOD ULE/UNI T REPLACEMENT PROCEDURE	143
6.1 NCRACK	144
6.1.1 POWERSUPPLY UNIT(MODELCPS-12N,MODELCPS-16F)	144
6.1.2 MODELJANCD-FC100B	146
6.1.3 MODELJANCD-FC190-1	148
6.1.4 MODELJANCD-FC200	150
6.1.5 MODELJANCD-FC210-1	152
6.1.6 MODEL JANCD-FC222/FC224	154
6.1.7 MODELJANCD-FC230B	156
6.1.8 MODELJANCD-FC242	158
6.1.9 MODELJANCD-FC300B-3	160
6.1.10 MODEL JANCD-FC250(INTEXB BOARD : STANDARD SPECIFICATIONS) ...	162
6.1.11 MODEL JANCD-FC251(INTEXB BOARD : HIGH-SPEED SPECIFICATIONS) ...	164
6.1.12 MODEL JANCD-FC250-1, 2 (MOTION BOARD)	166
6.1.13 MODEL JANCD-FC310-1	168
6.1.14 MODEL JANCD-FC400	170
6.1.15 MODEL JANCD-FC410	172
6.1.16 MODEL JANCD-FC420	174
6.1.17 MODEL JANCD-FC430	176
6.1.18 MODEL JANCD-FC440	178
6.1.19 BACK BOARD (MODELS JANCD-FC001,-FC002,-FC050,-FC052)	180
6.1.20 11-SLOT BACK BOARD (MODEL JANCD-FC006)	182
6.2 MACHINE CONTROL STATION	184
6.2.1 9" AMGC CONTROL PANEL (MODEL JZNC-IOP01)	184
6.2.2 14" ACGC CONTROL PANEL (MODEL JZNC-IOP11)	191



6.1 NC RACK

6.1.1 POWER SUPPLY UNIT (MODEL CPS-12N, MODEL CPS-16F)

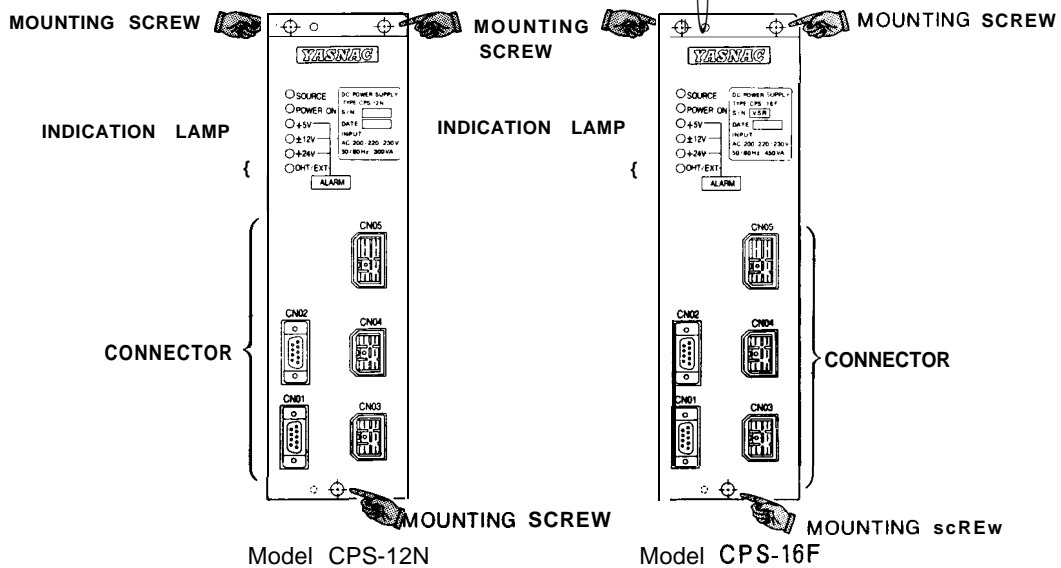

(1) Removal

- (a) Check that AC input power is not supplied [the SOURCE indication lamp (green) of the power supply unit is off], then pull out the CN03, CN04, and CN05 cables.
- (b) Loosen the mounting screws in the three positions in the figure and **remove** the power supply unit from the NC rack.

(2) Installation

- (a) Insert the power supply unit in line with the guide of the NC rack.
- (b) Loosen the mounting screws in the three positions in the figure.
- (c) Insert the CN03, CN04, and CN05 cables into the original positions.

(3) **Checking Functions After Replacement**

- (a) Check that +5V, $\pm 12V$, and +24V outputs are not shorted due to overloading.
- (b) Check that 200VAC input is in the range from 170 to 253VAC.
- (c) Check that 200VAC is supplied with SOURCE lamp on.
- (d) Check that upon the first application of power to the NC, each output is output normally and the alarm indication lamp (red) is off.

Normal value:

+5V	4.75 to	5.25V
+12V	11.87 to	13.12V
-12V	-11.87 to	-13.12V
+24V	20.4 to	27.6V

- (e) Check that the NC operates normally upon application of the second power to the NC.

6.1 NC RACK (Cent'd)

6.1.2 MODEL JANCD-FC100C

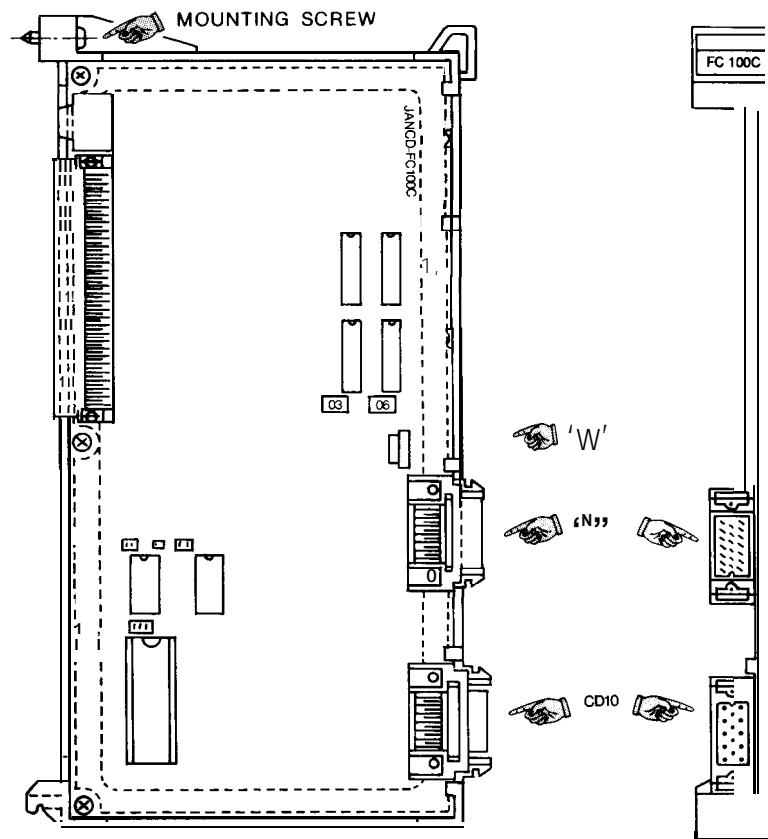

(1) Removal

(a) Check that AC input power **is** not supplied [the SOURCE indication lamp (green) of the power unit is off], then pull out the CN10 and CN11 cables.

(b) Loosen the mounting screw in the figure and remove the module from the NC rack.

(2) Installation

See the figure for the exterior of the module.

(a) Check the model and REV number of the replacement module for consistency.

(b) Check that the ROM number and label contents of the replacement module are the same as those of the module to be replaced.

- (c) **Set** SW1 on the module as it was before replacement.
- (d) Insert the module in line with the guide of the NC rack and tighten mounting screw.
- (e) Insert the CN10 and CN11 cables into the original positions.

(3) **Checking Functions After Replacement**

- (a) Check that +5V, $\pm 12V$, and +24V outputs are not shorted due to overloading.
- (b) Check that the initial is screen is displayed by initially applying power to the NC.
- (c) **Check** that keys on the control panel can be operated.
- (d) With model JANCD-FC903, check that switches on the machine control panel can be operated.

6.1 NC RACK (Cent'd)

6.1.3 MODEL JANCD-FC190-1

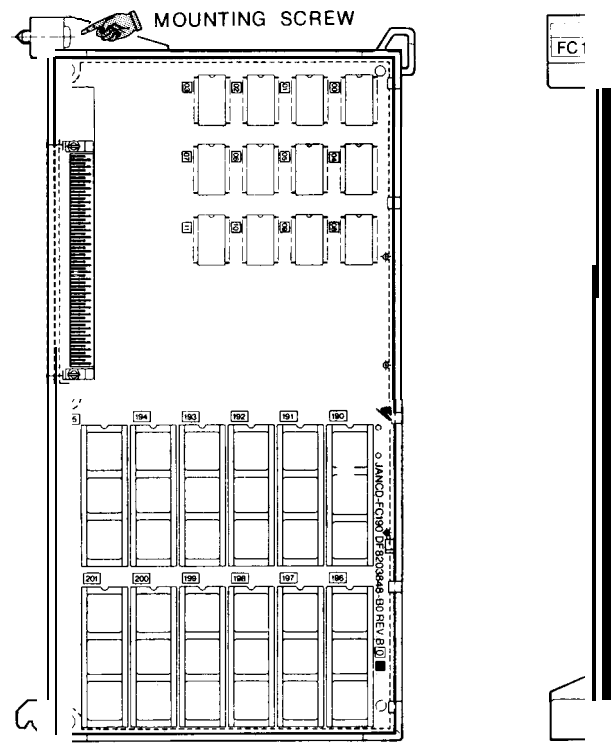

(1) Removal

Check that AC input power is not supplied [the SOURCE indication lamp (green) of the power unit is off], loosen the mounting screw in the figure, and remove the module from the NC rack.

(2) Installation

See the figure for the exterior of the module.

- (a) Check the model and REV number of the replacement module for consistency.
- (b) Check that the ROM number and label contents of the replacement module are the same as those of the module to be replaced.
- (c) Insert the module in line with the guide of the NC rack and tighten the mounting screw.

(3) **Checking Functions After Replacement**

- (a) Check that +5V, $\pm 12V$, and +24V outputs are not shorted due to overloading.
- (b) Check that the initial screen is displayed by applying the first power to the NC.

6.1 NC RACK (Cent'd)

6.1.4 MODEL JANCD-FC200

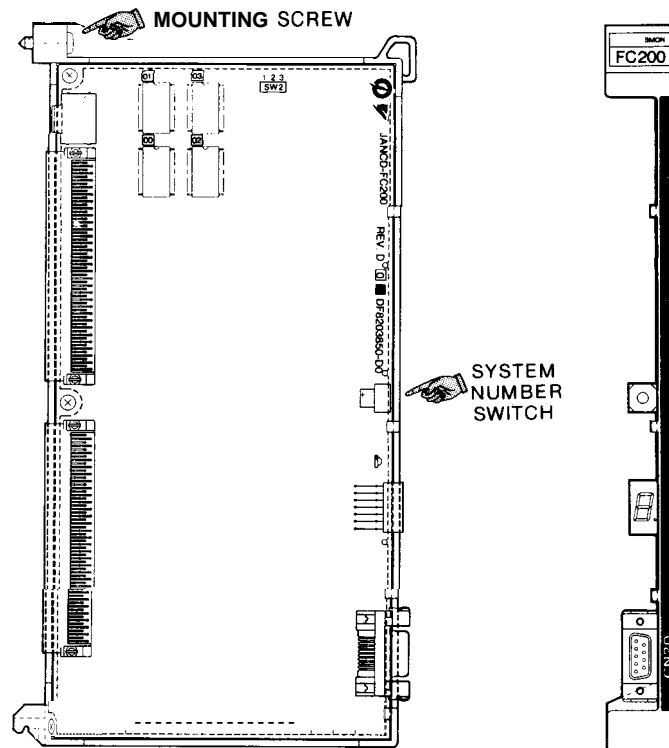

This module contains CMOS RAM in which NC program parameter values and offset values are stored. Accordingly, their contents must be copied when replacing the module.

(1) Removal

Check that AC input power is not supplied [the SOURCE indication lamp (green) of the power unit is off 1, loosen the mounting screw in the figure, and remove the module from the NC rack.

(2) Installation

See the figure for the exterior of the module.

- (a) Check the model and REV number of the replacement module for consistency.
- (b) Check that the system number switch of the replacement module is 0.
- (c) Insert the module in line with the guide of the NC rack and tighten the mounting screw.

(3) Checking Functions After Replacement

- (a) Check that +5V, $\pm 12V$, and +24V outputs are not shorted due to overloading.
- (b) Check that the initial screen is displayed by initially applying power to the NC.
- (c) Store the NC program, parameter values, and offset values copied in advance.
- (d) After turning power off, apply the initial power and second power again and check that no alarm occurs.

6.1 NC RACK (Cent'd)

6.1.5 MODEL JANCD-FC210-1

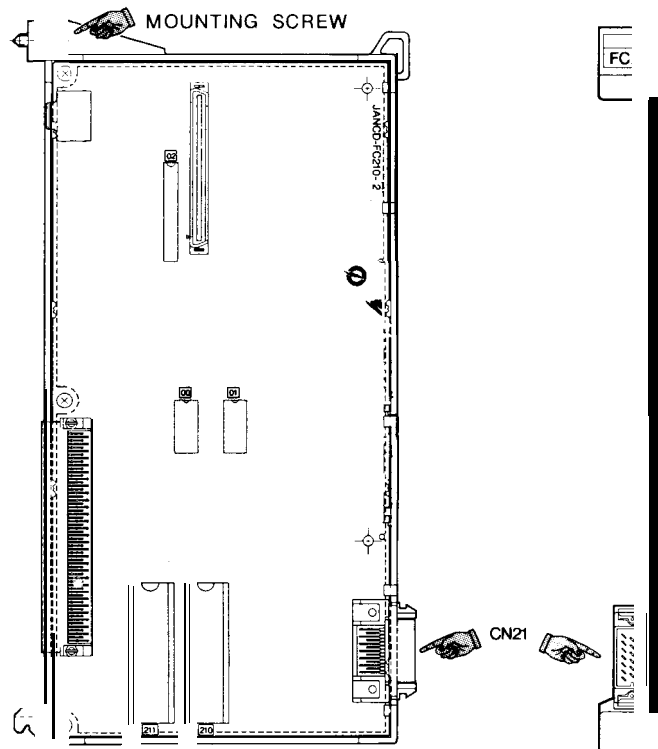

(1) Removal

- (a) Check that AC input power is not supplied [the SOURCE indication lamp (green) of the power unit is off], then pull out the CN21 cable.
- (b) Loosen the mounting screw in the figure and remove the module from the NC rack.

(2) Installation

See the figure for the exterior exterior of the module.

- (a) Check the model and REV number of the replacement module for consistency.
- (b) Check that the label **contents** and ROM numbers 210 and 211 of the replacement module are the same as those of the module to be replaced.

(c) **Insert** the module in line with the guide of the NC rack and tighten the mounting screw.

(d) Insert the CN21 cable into the original position.

(3) Checking Functions After Replacement

(a) Check that +5V, $\pm 12V$, and +24V outputs are not shorted due to overloading.

(b) Apply the initial power and second power again and check that no alarm occurs.

6.1 NC RACK (Cent'd)

6.1.6 MODEL JANCD-FC222/FC224

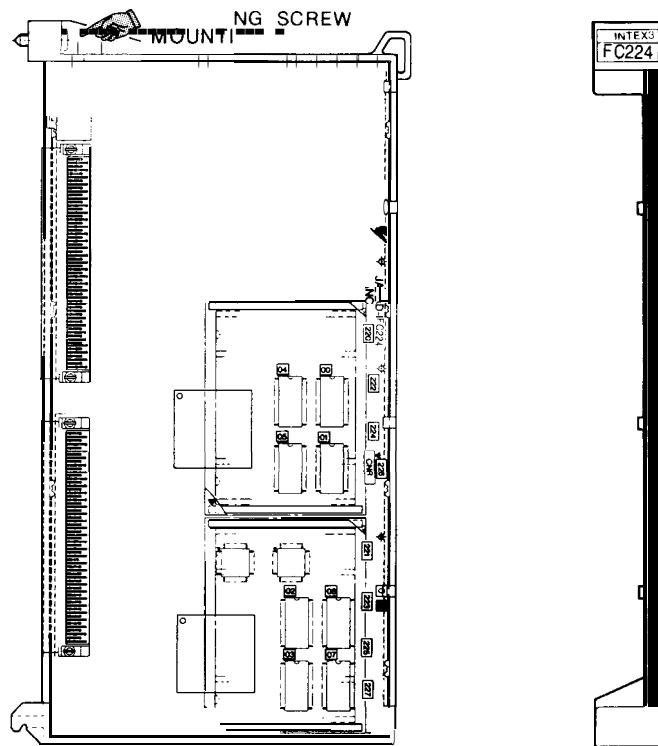

(1) Removal

Check that AC input power is not supplied [the SOURCE indication lamp (green) of the power unit is off], loosen the mounting screw in the figure, and remove the module from the NC rack.

(2) Installation

See the figure for the exterior of the module.

- (a) Check the model and REV number of the replacement module for consistency.
- (b) Check that the ROM number and label contents of the replacement module are the same as those of the module to be replaced.
- (c) Insert the module in line with the guide of the NC rack and tighten the mounting screw.

(3) **Checking Functions After Replacement**

- (a) Check that +5V, $\pm 12V$, and +24V outputs are not shorted due to overloading.
- (b) Apply the first power and second power again and check that no alarm occurs.

6.1 NC RACK (Cent'd)

6.1.7 MODEL JANCD-FC230B

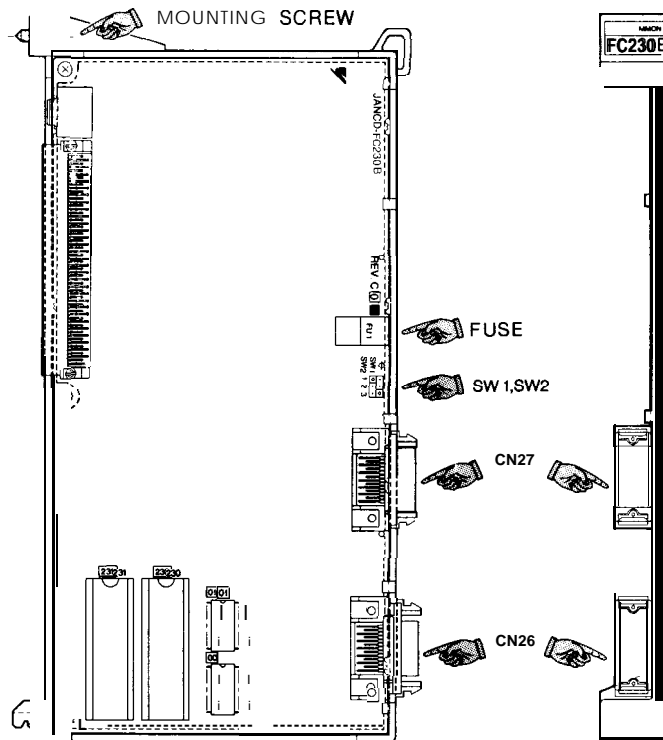

(1) Removal

- (a) Check that AC input power is not supplied [the SOURCE indication lamp (green) of the power unit is off], then pull out the CN26 and CN27 cables.
- (b) Loosen the mounting screw in the figure and remove the module from the NC rack.

(2) Installation

See the figure for the exterior of the module.

- (a) Check the model and REV number of the replacement module for consistency.
- (b) Check that the ROM number and label contents of the replacement module are the same as those of the module to be replaced.
- (c) Set SW1 and SW2 on the module as they were before replacement.

- (d) Check visually that the fuse is not blown.
- (e) Insert the module in line with the guide of the NC rack and tighten mounting screw.
- (f) Insert the CN26 and CN27 cables into the original positions.

(3) Checking Functions After Replacement

- (a) Check that +5V, $\pm 12V$, and +24V outputs are not shorted due to overloading.
- (b) **Apply** the first power and second power again and check that no alarm occurs.

6.1 NC RACK (Cent'd)

6.1.8 MODEL JANCD-FC242

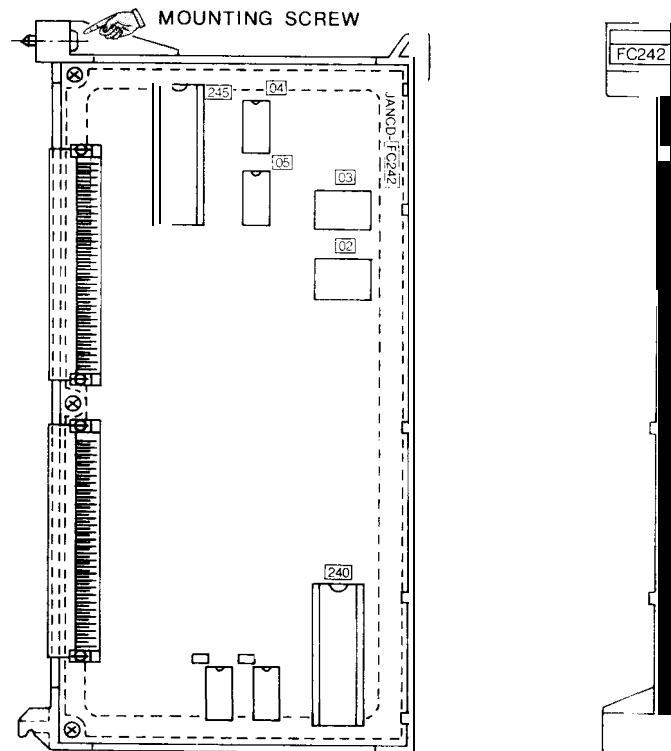

(1) Removal

Check that AC input power is not supplied [the SOURCE indication lamp (green) of the power unit is off], loosen the mounting screw in the figure, and remove the module from the NC rack.

(2) Installation

See the figure for the exterior of the module.

- (a) Check the model and REV number of the replacement module for consistency.
- (b) Check that the ROM number and label contents of the replacement module are the same as those of the module to be replaced.
- (c) Insert the module in line with the guide of the NC rack and tighten mounting screw.

(3) **Checking Functions After Replacement**

- (a) Check that +5V, $\pm 12V$, and +24V outputs are not shorted due to overloading.
- (b) Apply the first power and second power again and check that no alarm occurs.

6.1 NC RACK (Cent'd)

6.1.9 MODEL JANCD-FC300B-3

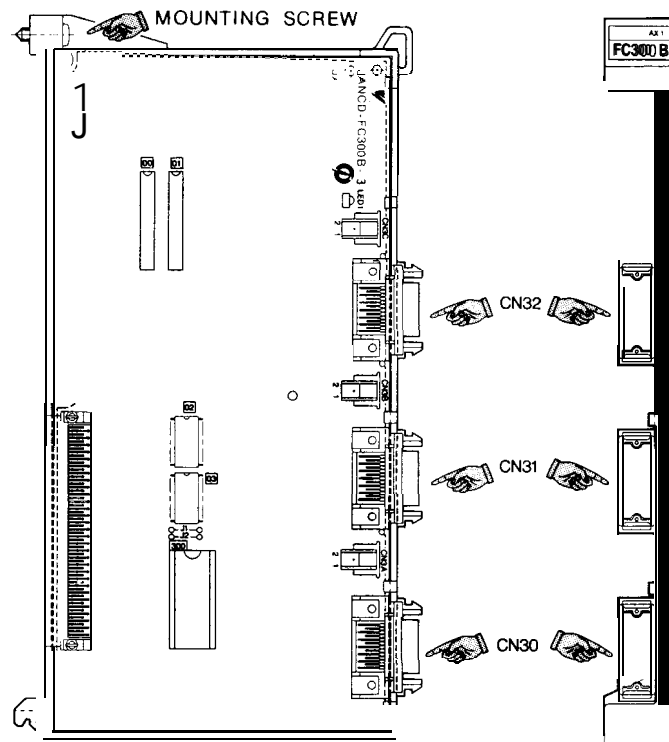

(1) Removal

- (a) Check that AC input power is not supplied [the SOURCE indication lamp (green) of the power unit is off], then pull out the CN30, CN31, and CN32 cables.
- (b) Loosen the mounting screw in the figure and remove the module from the NC rack.

(2) Installation

See the figure for the exterior of the module.

- (a) Check the model and REV number of the replacement module for consistency.
- (b) Check that the ROM number and label contents of the replacement module are the same as those of the module to be replaced.

- (c) Insert the module in line with the guide of the NC rack and tighten mounting screw.
- (d) Insert the CN30, CN31, and CN32 cables into the original positions.

(3) Checking Functions After Replacement

- (a)** Check that +5V, $\pm 12V$, and +24V outputs are not shorted due to overloading.
- (b) Apply the first power and second power again and check that no alarm occurs.
- (c) Check that the feed axis can be controlled manually.

6.1 NC RACK (Cent'd)

6.1.10 MODEL JANCD-FC250 (INTEXB BOARD : STANDARD SPECIFICATIONS)

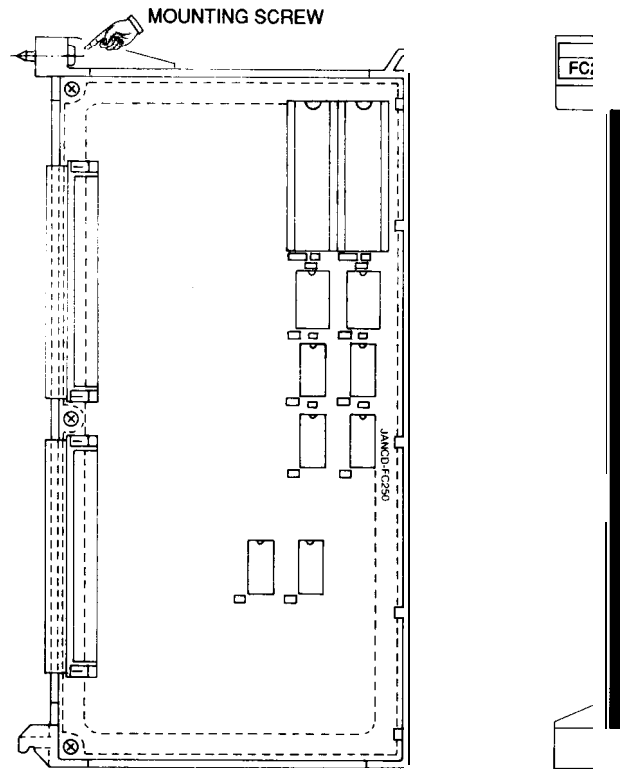

(1) Removal

- (a) Check that AC input power is not supplied [the SOURCE indication lamp (green) of the power unit CPS-12N is off].
- (b) Loosen the mounting screw in the figure and remove the module from the NC rack.

(2) Installation

- (a) Check the model and REV number of the replacement module for consistency.
- (b) Check that the ROM number and label contents of the replacement module are the same as those of the module to be replaced.
- (c) Insert the module in line with the guide of the NC rack and tighten mounting screw.

(3) Checking Functions After Replacement

- (a)** Check that + 5V, $\pm 12V$, and + 24V outputs are not shorted due to overloading.
- (b)** Apply the first power and second power again and check that no alarm occurs.

6

6.1 NC RACK (Cent'd)

6.1.11 MODEL JANCD-FC251(INTEXB BOARD : HIGH-SPEED SPECIFICATIONS)

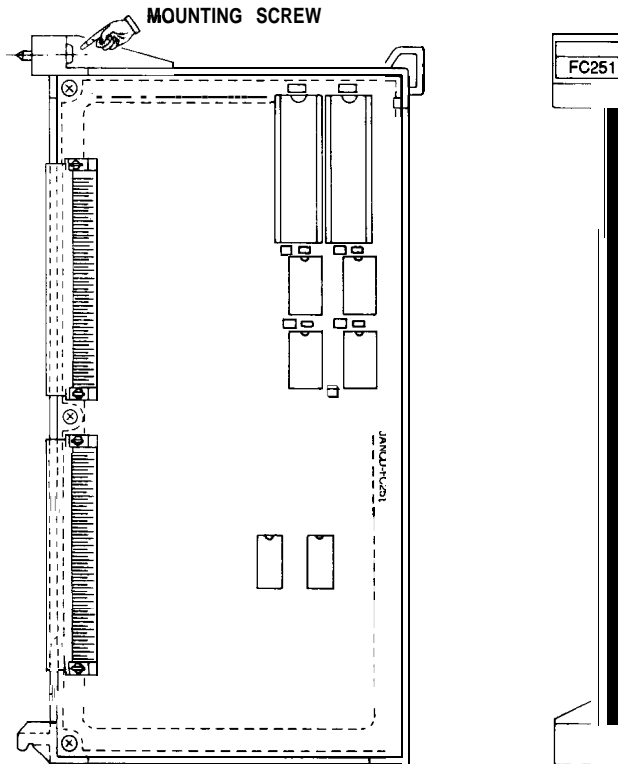

(1) Removal

- (a) Check that AC input power is not supplied [the SOURCE indication lamp (green) of the power unit CPS-12N is off].
- (b) Loosen the mounting screw in the figure and remove the module from the NC rack.

(2) Installation

- (a) Check the model and REV number of the replacement module for consistency.
- (b) Check that the ROM number and label contents of the replacement module are the same as those of the module to be replaced.
- (c) Insert the module in line with the guide of the NC rack and tighten mounting screw.

(d) Insert the CN10 and CN11 cables into the original position.

(3) Checking Functions After Replacement

(a) Check that + 5V, \pm 12V, and + 24V outputs are not shorted due to overloading.

(b) Apply the first power and second power again and check that no alarm occurs.

6.1 NC RACK (Cent'd)

6.1.12 MODEL JANCD-FC250-I ,2 (MOTION BOARD)

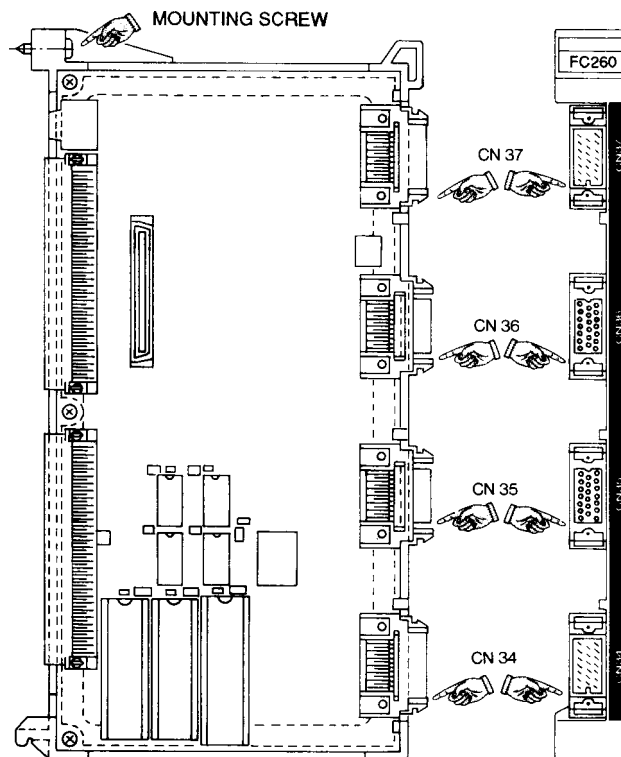

(1) Removal

- (a) Check that AC input power is not supplied [the SOURCE indication lamp (green) of the power unit CPS-12N is off].
- (b) Pull out the cables connected to CN26, CN27, CN34, and CN35 .
- (c) Loosen the mounting screw in the figure and remove the module from the NC rack.

(2) Installation

- (a) Check the model and REV number of the replacement module for consistency.
- (b) Check that the ROM number and label contents of the replacement module are the same as those of the module to be replaced.

- (c) Return the settings of SW1 and SW2 on the module to those made before the replacement.
- (d) Check visually that the fuse is not blown.
- (e) Insert the module in line with the guide of the NC rack and tighten mounting screw.
- (f) Insert the CN26, CN27, CN34, and CN35 cables into the original position.

(3) Checking Functions After Replacement

- (a)** Check that +5V, $\pm 12V$, and +24V outputs are not shorted due to overloading.
- (b) Apply the first power and second power again and check that no alarm occurs.

6.1 NC RACK (Cent'd)

6.1.1.3 MODEL JANCD-FC310-1

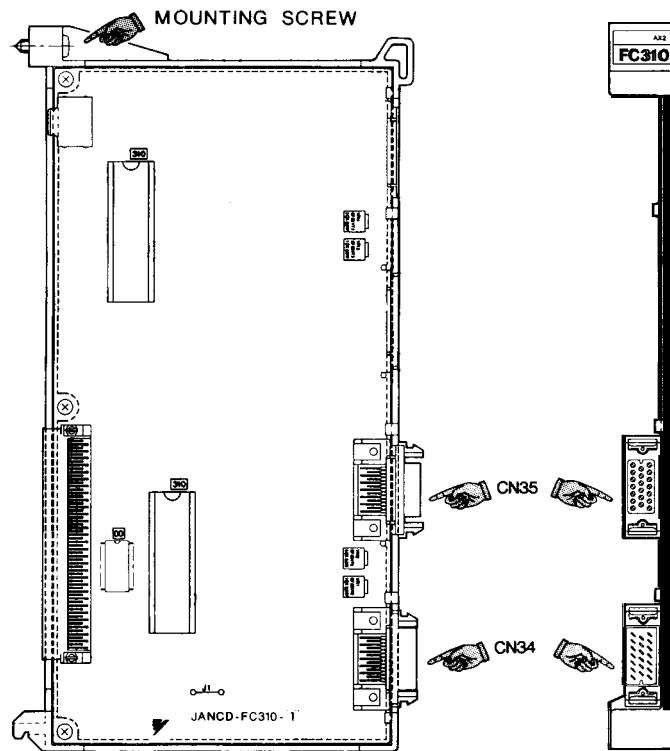

(1) Removal

- (a) Check that AC input power is not supplied [the SOURCE indication lamp (green) of the power unit is off], then pull out the CN34 and CN35 cables.
- (b) Loosen the mounting screw in the figure and remove the module from the NC rack-.

(2) Installation

See the figure for the exterior of the module.

- (a) Check the model and REV number of the replacement module for consistency.
- (b) Check that the ROM number and label contents of the replacement module are the same as those of the module to be replaced.
- (c) Insert the module in line with the guide of the NC rack and tighten mounting screw.

(d) Insert the CN34 and CN35 cables into the original positions.

(3) **Checking Functions After Replacement**

- (a) Check that +5V, $\pm 12V$, and +24V outputs are not shorted due to overloading.
- (b) Apply the first power and second power again and check that no alarm occurs.
- (c) Check that the spindle can be controlled manually.

6.1 NC RACK (Cent'd)

6.1.14 MODEL JANCD-FC400

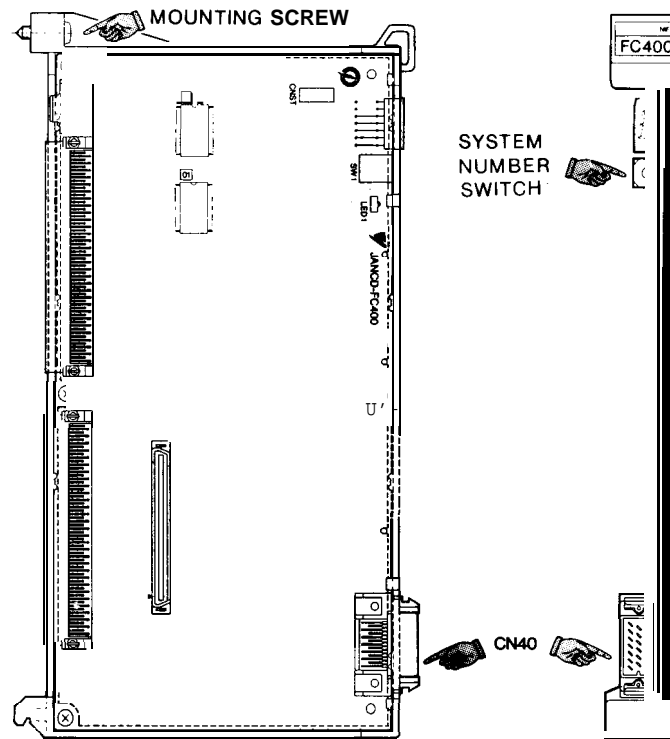

(1) Removal

- (a) Check that AC input power is not supplied [the SOURCE indication lamp (green) of the power unit is off], then pull out the CN40 cable.
- (b) Loosen the mounting screw in the figure and remove the module from the NC rack.

(2) Installation

See the figure for the exterior of the module.

- (a) Check the model and REV number of the replacement module for consistency
- (b) Check that the system number switch of the replacement module is 0.
- (c) Insert the module in line with the guide of the NC rack and tighten mounting screw.
- (d) Insert the CN40 cable into the original position.

(3) **Checking Functions After Replacement**

- (a) Check that +5V, $\pm 12V$, and +24V outputs are not shorted due to overloading.
- (b) Apply the first power and second power again and check that no alarm occurs.
- (c) With model JANCD-FC903, check that switches on the machine control panel can be operated.

6.1 NC RACK (Cent'd)

6.1.15 MODEL JANCD-FC410

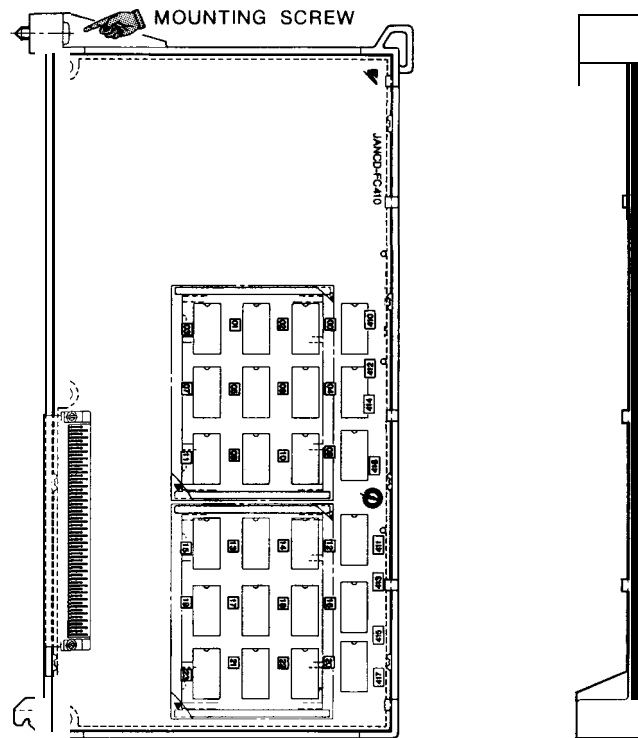

(1) Removal

Check that AC input power is not supplied [the SOURCE indication lamp (green) of the power unit is off], loosen the mounting screw in the figure, and remove the module from the NC rack.

(2) Installation

See the figure for the exterior of the module.

- (a) Check the model and REV number of the replacement module for consistency.
- (b) Check that the ROM number and label contents of the replacement module are the same as those of the module to be replaced.
- (c) Insert the module in line with the guide of the NC rack and tighten mounting screw.

(3) **Checking Functions After Replacement**

- (a) Check that +5V, $\pm 12V$, and +24V outputs are not shorted due to overloading.
- (b) Apply the first power and second power again and check that no alarm occurs.

6.1 NC RACK (Cent'd)

6.1.16 MODEL JANCD-FC420

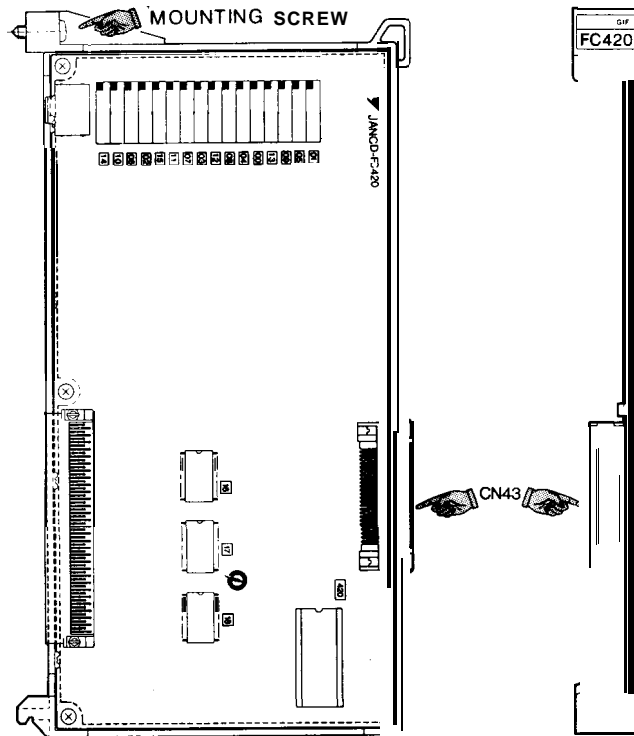

(1) Removal

- (a) Check that AC input power is not supplied [the SOURCE indication lamp (green) of the power unit is off], then pull out the CN43 cable.
- (b) Loosen the mounting screw in the figure and remove the module from the NC rack.

(2) Installation

See the figure for the exterior of the module.

- (a) Check the model and REV number of the replacement module for consistency.
- (b) Check that the ROM number and label contents of the replacement module are the same as those of the module to be replaced.

(c) Insert the module in line with the guide of the NC rack and tighten mounting screw.

(d) Insert the CN43 cable into the original position.

(3) Checking Functions After Replacement

(a) Check that +5V, $\pm 12V$, and +24V outputs are not shorted due to overloading.

(b) Apply the first power and second power again and check that no alarm occurs.

6.1 NC RACK (Cent'd)

6.1.17 MODEL JANCD-FC430

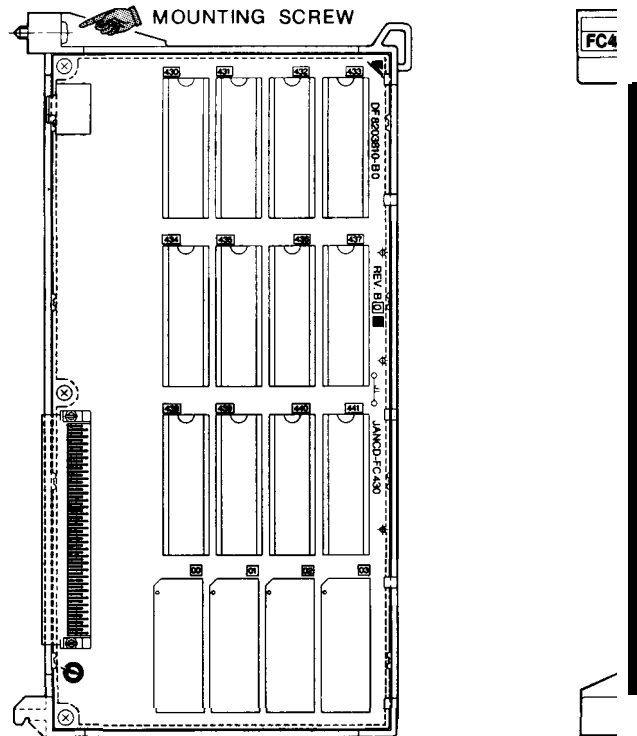

This module contains CMOS RAM in which **ACGC** application programs are stored. Accordingly, their contents must be copied when replacing the module.

(1) Removal

Check that AC input power is not supplied [the SOURCE indication lamp (green) of the power unit is off], loosen the mounting screw in the figure, and remove the module from the NC rack.

(2) Installation

See the figure for the exterior of the module.

- (a) Check the model and REV number of the replacement module for consistency.

- (b) Check that the ROM number and label contents of the replacement module are the same as those of the module to be replaced.
- (c) Insert the module in line with the guide of the NC rack and tighten mounting screw.

(3) **Checking Functions After Replacement**

- (a) Check that +5V, $\pm 12V$, and +24V outputs are not shorted due to overloading.
- (b) Check that the initial screen is displayed by applying the first power to the NC.
- (c) Store the ACGC application programs copied in advance.
- (d) After turning power off, apply the first power and second power again and check that no alarm occurs.

6.1 NC RACK (Cent'd)

6.1.18 MODEL JANCD-FC440

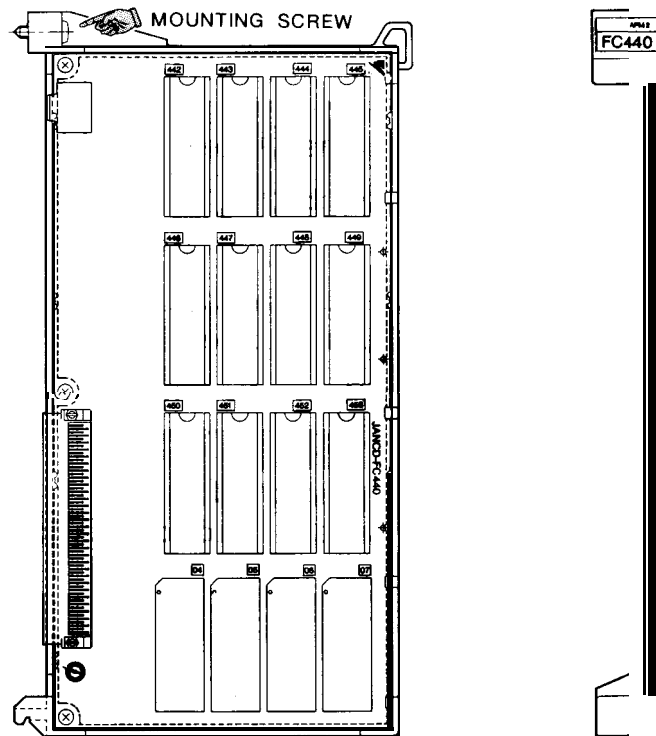

This module contains CMOS RAM in which ACGC application programs are stored. Accordingly, their contents must be copied when replacing the module,

(1) Removal

Check that AC input power is not supplied [the SOURCE indication lamp (green) of the power unit is off], loosen the mounting screw in the figure, and remove the module from the NC rack.

(2) Installation

See the figure for the exterior of the module.

- (a) **Check** the model and REV number of the replacement module for consistency.

- (b) Check that the ROM number and label contents of the replacement module are the same as those of the module to be replaced.
- (c) Insert the module in line with the guide of the NC rack and tighten mounting screw.

(3) **Checking Functions After Replacement**

- (a) Check that +5V, $\pm 12V$, and +24V outputs are not shorted due to overloading.
- (b) Check that the initial screen is displayed by applying the first power to the NC.
- (c) Store the ACGC application programs copied in advance.
- (d) After turning power off, apply the first **power** and second power again and check that no alarm occurs.

6.1 NC RACK (Cent'd)

6.1.19 BACK BOARD (MODELS JANCD-FC001, -FC002, -FC050, -FC052)

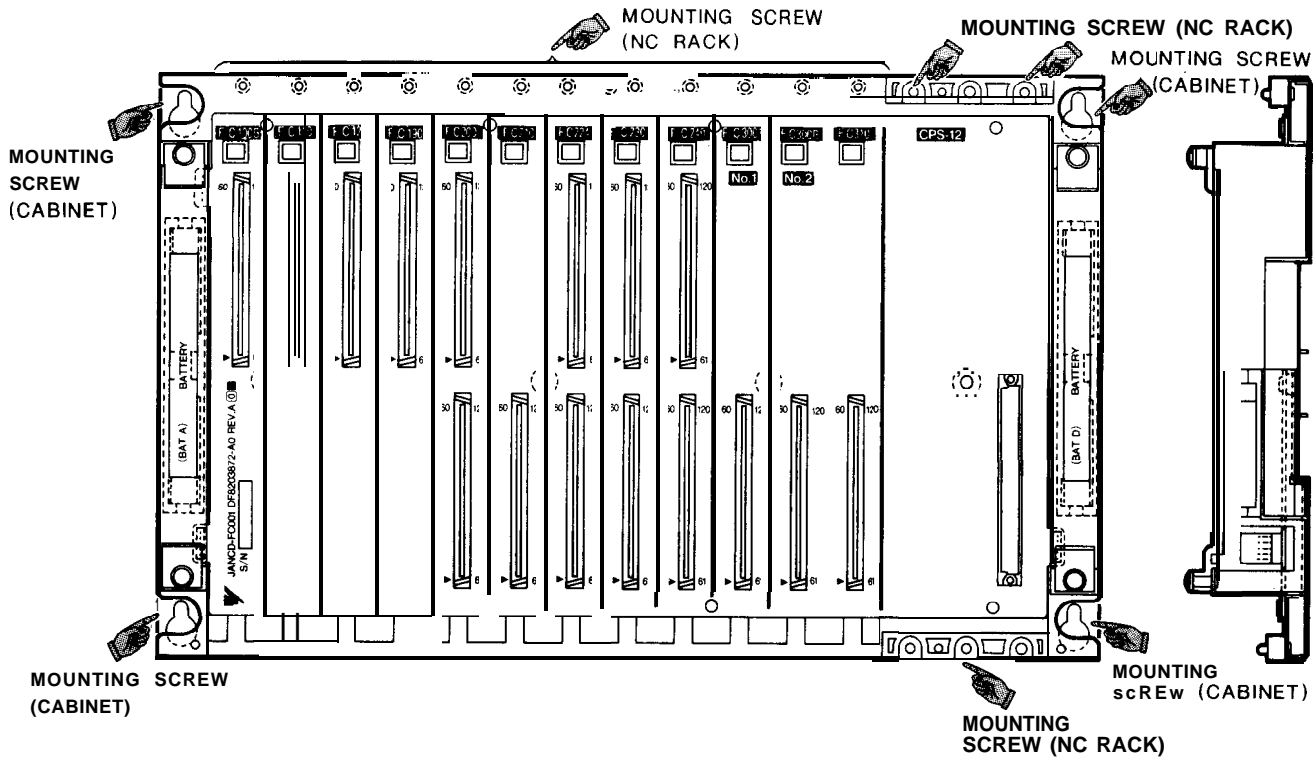

(1) Removal

- (a) Check that AC input power is not supplied [the SOURCE indication lamp (green) of the power unit is off.]
- (b) Pull out all cables connected to the NC rack.
- (c) Loosen the mounting screws (NC rack) in the figure and remove all modules from the NC rack.
- (d) Loosen the mounting screws (cabinet) in the figure and remove the modules from the cabinet.

(2) Installation

See the figure for the exterior of the module.

- (a) Check the model and REV number of the replacement module for consistency.

- (b) Install the module in the cabinet and tighten the mounting screws.
- (c) Insert all modules in line with the guide of the NC rack and tighten mounting screws (NC rack) .
- (d) Insert all the cables into the original positions.

(3) **Checking Functions After Replacement**

- (a) Check that +5V, $\pm 12V$, and +24V outputs are not shorted due to overloading.
- (b) Apply the first power and second power again and check that no alarm occurs.

Note

FC200 (SMON) and FC120 (FILE: optional) boards are provided with CMOS RAM (programs, parameters and offset data) and with backup by super capacitor. Therefore, installation must be completed within 16 hours after removal of the boards.

6.1 NC RACK (Cent'd)

6.1.20 11-SLOT BACK BOARD (MODEL JANCD-FC006)

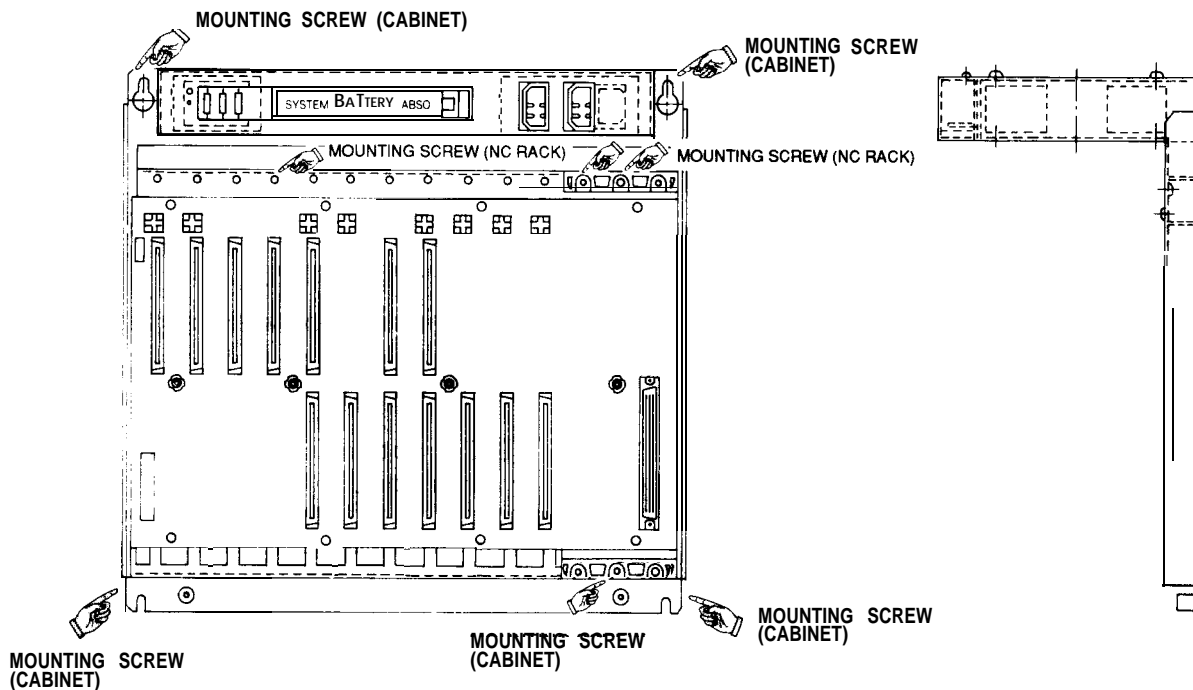

(1) Removal

- (a) Check that AC input power is not supplied [the SOURCE indication-lamp (green) of the power unit is off]
- (b) Pull out all cables connected to the NC rack.
- (c) Loosen the mounting screws (NC rack) in the figure and remove all modules from the NC rack.
- (d) Loosen the mounting screws (cabinet) in the figure and remove the modules from the cabinet.

(2) Installation

- (a) Check the model and REV number of the replacement module for consistency.
- (b) Install the module in the cabinet and tighten the mounting screws.

(c) Insert all modules in line with the guide of the NC rack and tighten mounting screws (NC rack).

(d) **insert** all the cables into the original positions.

(3) **Checking Functions After Replacement**

(a) Check that + 5V, \pm 12V, and + 24V outputs are not shorted due to overloading.

(b) Apply the first power and second power again and check that no alarm occurs.

Note

FC200 (SMON) and FC120 (FILE: optional) boards are provided with CMOS RAM (programs, parameters and offset data) and with backup by super capacitor. Therefore, installation must be completed within 16 hours after removal of the boards.

6.2 MACHINE CONTROL STATION

6.2.1 9" AMGC CONTROL PANEL (MODEL JZNC-IOP01)

6.2.1.1 MODEL JANCD-FC900B

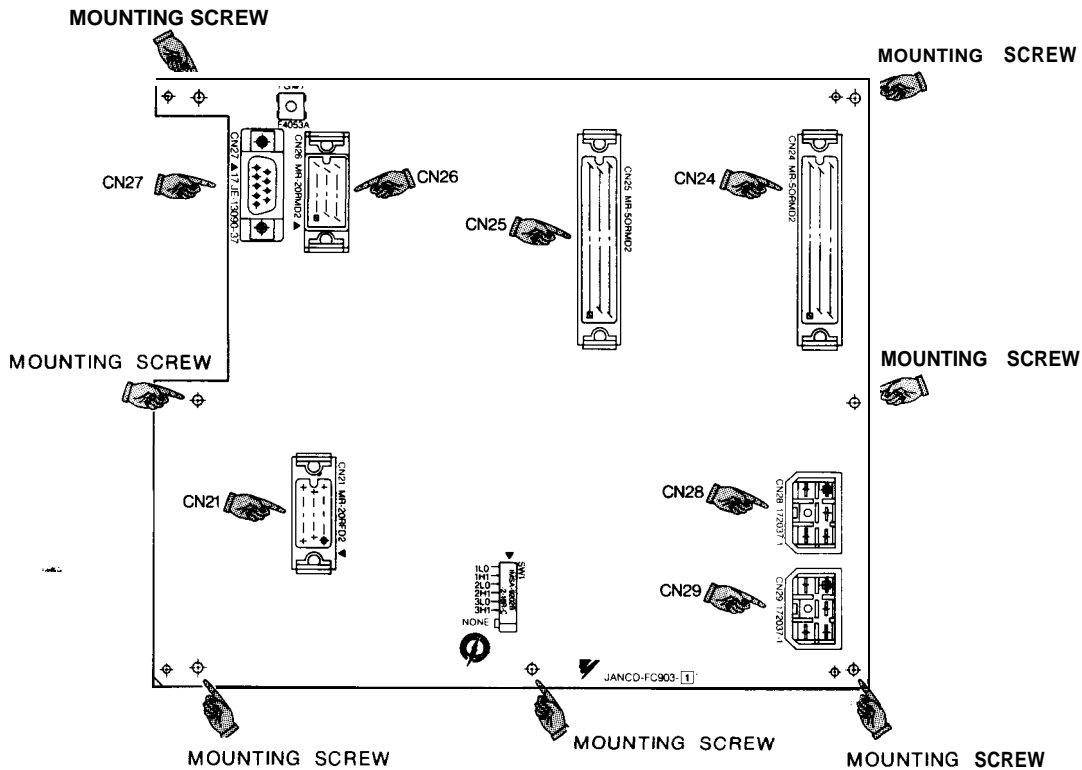
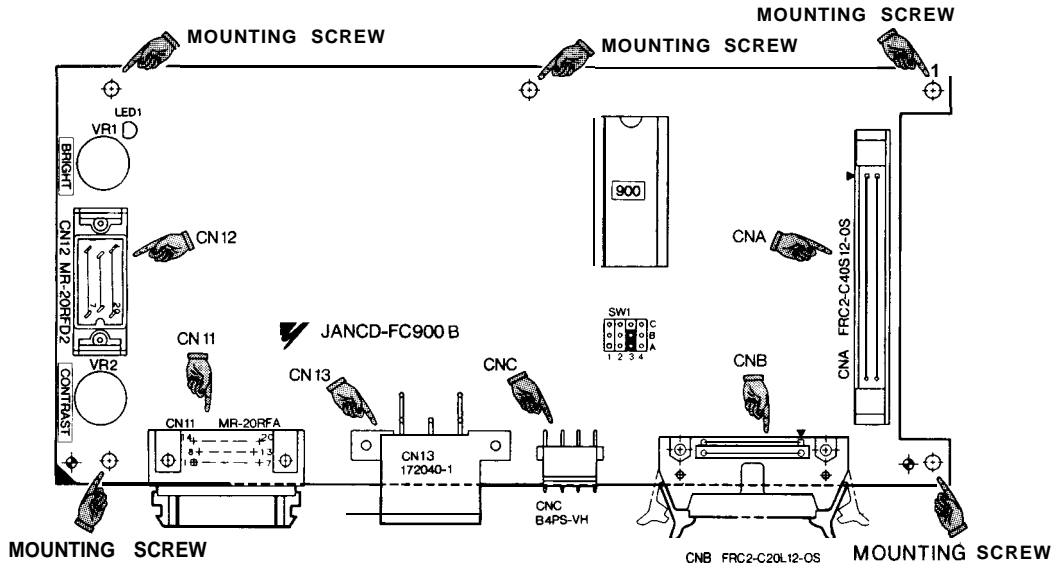

(1) Removal

- (a) Check that AC input power is not supplied [the SOURCE indication lamp (green) of the power unit is off], then pull out cables connected to CN21, CN24, CN25, CN26, CN27, CN28, and CN29 of model JANCD-FC903-1.
- (b) Loosen the mounting screws of model JANCD-FC903-1 and remove model JANCD-FC903-1 from the control panel.
- (c) Pull out the cables connected to CN11, CN12, CN13, CNA, CNB, and CNC of model JANCD-FC900B.
- (d) Loosen the mounting screws of model JANCD-FC900B and remove model JANCD-FC900B from the control panel.

(2) Installation

See the figure for the exterior of the module.

- (a) Check the model and REV number of the replacement module for consistency.
- (b) Check that the ROM number and label contents of the replacement module are the same as those of the module to be replaced.
- (c) Check that the setting of SW1 is the same as that before replacement.
- (d) Install model JANCD-FC900B on the control panel.
- (e) Connect the cables to CN11, CN12, CN13, CNA, CNB, and CNC of model JANCD-FC900B.
- (f) Install model JANCD-FC903-1 on the control panel.
- (g) Insert all remaining cables to the original positions.

(3) Checking Functions After Replacement

- (a) Check that +5V, +12V, and +24V outputs are not shorted due to overloading.
- (b) Apply the first power and second power again and check that no alarm occurs.

6.2 MACHINE CONTROL STATION (Cent'd)

- (c) Check that the brightness and contrast of the CRT are normal.
- (d) Check that keys on the control panel can be operated and the buzzer sounds.
- (e) Check that switches on the machine control panel can be operated.

6.2.1.2 MODEL JANCD-FC901

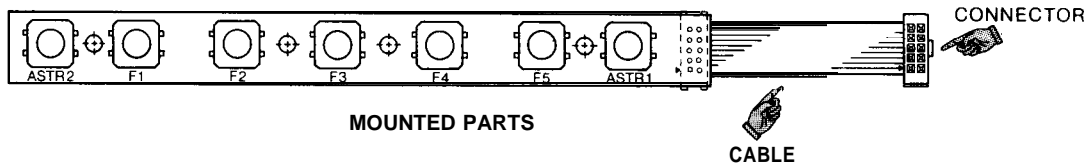

(1) Removal

- (a) Check that AC input power is not supplied [the SOURCE indication lamp (green) of the power unit is off], then pull out the cable of model JANCD-FC901 connected to CNB of the keyboard.
- (b) Loosen the cover mounting screws and remove the CRT cover from the control panel.
- (c) Loosen the mounting screws and remove model JANCD-FC901 from the control panel.

(2) Installation

See the figure for the exterior of the function keyboard.

- (a) Check the model and REV number of the replacement function keyboard for consistency.
- (b) Install model JANCD-FC901 on the control panel.
- (c) Install the cover on the control panel.
- (d) Insert the model JANCD-FC901 cable into the original position of the keyboard.

6

(3) Checking Functions After Replacement

- (a) Check that +5V, +12V, and +24V outputs are not shorted due to overloading.
- (b) Apply the first power and second power again and check that no alarm occurs.
- "(c) Check that keys on the control panel can be operated.

6.2 MACHINE CONTROL STATION (Cent'd)

6.2.1.3 MODEL JANCD-FC903-1

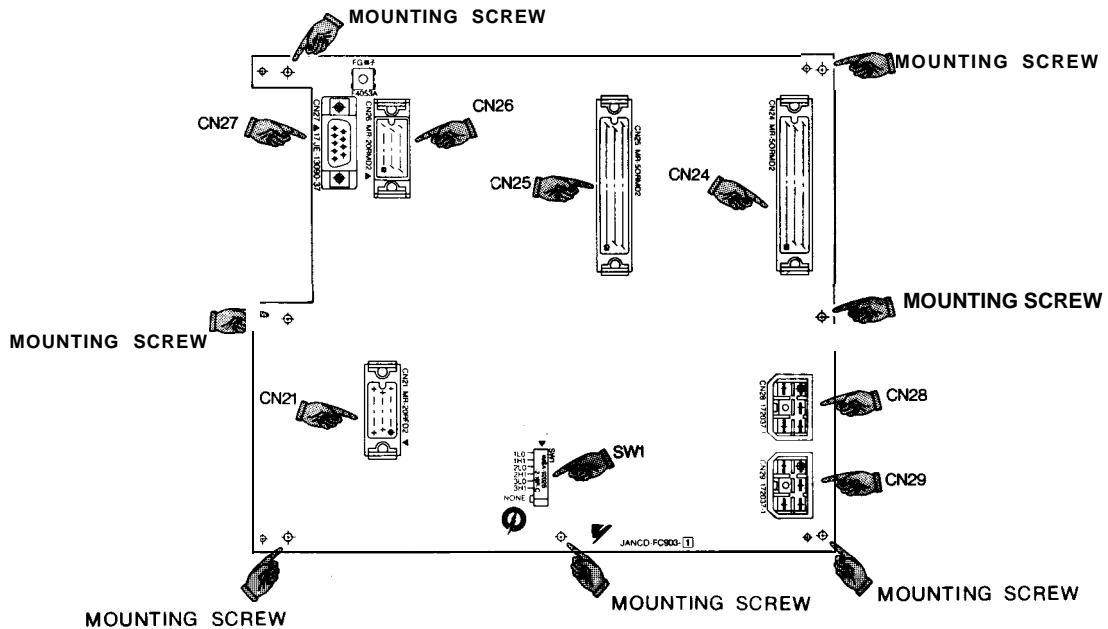

(1) Removal

- (a) Check that AC input power is not supplied [the SOURCE indication lamp (green) of the power unit is off], then pull out cables connected to CN21, CN24, CN25, CN26, CN27, CN28, and CN29 of model JANCD-FC903-1O
- (b) Loosen the mounting screws of model JANCD-FC900B and remove model JANCD-FC903 from the control panel.

(2) Installation

See the figure for the exterior of the module.

- (a) Check the model and REV number of the replacement module for consistency.
- (b) Check that the setting of SW1 is the same as that before replacement.
- (c) Install model JAN CD-FC903-1 on the control panel according to the figure.
- (d) Insert all cables to the original positions.

(3) **Checking Functions After Replacement**

- (a) Check that +5V, +12V, and +24V outputs are not shorted due to overloading.
- (b) Apply the first power and second power again and check that no alarm occurs.
- (c) Check that switches on the machine control panel can be operated.

6.2.1.4 9" **MONOCHROME GRAPHIC CRT UNIT (MDT948-3B)**

(1) **Removal**

- (a) Check that AC input power is not supplied [the SOURCE indication lamp (green) of the power unit is off], then pull out the cable connected to CNB of model JANCD-FC900B.
- (b) Loosen the mounting screws and remove CRT from the control panel.

(2) **Installation**

- (a) Check the model and REV number of the replacement module for consistency.
- (b) Insert the cable to the original position.

(3) **Checking Functions After Replacement**

- (a) Check that +5V, +12V, and +24V outputs are not shorted due to overloading.
- (b) Apply the first power and second power again and check that no alarm occurs.
- (c) Check that the brightness and contrast of the CRT are normal.

6.2 MACHINE CONTROL STATION (Cent'd)

6.2.1.5 KEYBOARD (MODEL DF8203788)

(1) Removal

- (a) Check that AC input power is not supplied [the SOURCE indication lamp (green) of the power unit is off], then pull out cables connected to CN21, CN24, CN25, CN26, CN27, CN28, and CN29 of model JANCD-FC903-1.
- (b) Loosen the mounting screws of model JANCD-FC900B and remove model JANCD-FC903 from the control panel,
- (c) Pull out the cables connected to CN12, CN13, CNA, CNB, and CNC of model JANCD-FC900B.
- (d) **Loosen the mounting screws and remove model JAN CD-FC900B from the control panel.**
- (e) Loosen the mounting screws and remove the keyboard from the control panel.

(2) Installation

- (a) Check the model and REV number of the replacement module for consistency.
- (b) Install keyboard on the control panel.
- (c) Install model JANCD-FC900B on the control panel.
- (d) Connect the cables to CN12, CN13, CNA, CNB, and CNC of model JANCD-FC900B.
- (e) Install model JANCD-FC903-1 on the control panel.
- (f) Insert all remaining cables to the original positions.

(3) Checking Functions After Replacement

- (a) Check that +5V, +12V, and +24V outputs are not shorted due to overloading.
- (b) Apply the first power and second power again and check that no alarm occurs.
- (c) **Check** that keys on the control panel can be operated and the buzzer sounds.

6.2.2 14" ACGC CONTROL PANEL (MODEL JZNC-IOP11)

6.2.2.1 MODEL JANCD-FC950-1

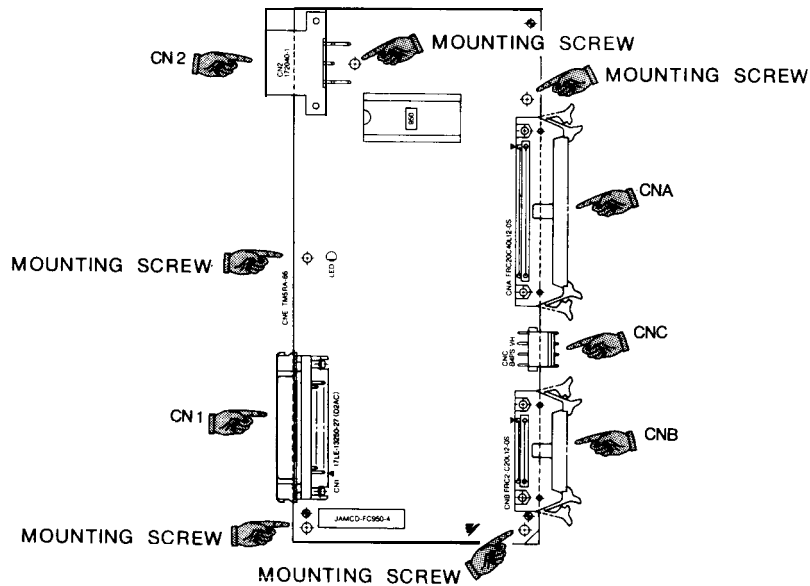

(1) Removal

- (a) Check that AC input power is not supplied [the SOURCE indication lamp (green) of the power unit is off], then pull out cables connected to CNA, CNB, CNC, CN1, and CN2.
- (b) Loosen the mounting screws in the figure and remove model JANCD-FC950-1 from the control panel.

(2) Installation

See the figure for the exterior of the module.

- (a) Check the model and REV number of the replacement module for consistency.
- (b) Check that the ROM number and label contents of the replacement module are the same as those of the module to be replaced.
- (c) Install model JANCD-FC950-1 on the control panel.
- (d) Insert all the cables of model JANCD-FC950-1 to the original positions.

6

6.2 MACHINE CONTROL STATION (Cent'd)

(3) Checking Functions After Replacement

- (a) Check that +5V, +12V, and +24V outputs are not shorted due to overloading.
- (b) Apply the first power and second power again and check that no alarm occurs.
- (c) Check that the brightness and contrast of the CRT are normal.
- (d) Check that keys on the control panel can be operated and the buzzer sounds.

6.2.2.2 MODEL JANCD-FC951

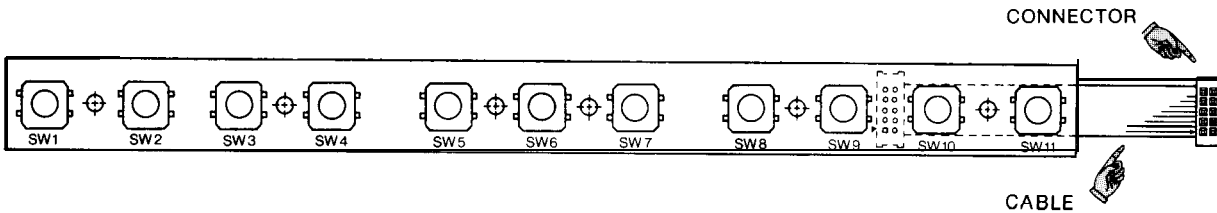

(1) Removal

- (a) Check that AC input power is not supplied [the SOURCE indication lamp (green) of the power unit is off], then pull out the cable of model JANCD-FC951 connected to CNB of the keyboard.
- (b) Loosen the mounting screws and remove the CRT cover from the control panel.
- (c) Loosen the mounting screws and remove model JANCD-FC951 from the control panel.

(2) Installation

See the figure for the exterior of the function keyboard.

- (a) Check the model and REV number of the replacement function keyboard for consistency.
- (b) Install model JANCD-FC951 on the control panel.
- (c) Install the cover on the control panel.
- (d) Insert the model JANCD-FC951 cable into the original position of the keyboard.

6

(3) Checking Functions After Replacement

- (a) Check that +5V, +12V, and +24V outputs are not shorted due to overloading.
- (b) Apply the first power and second power again and check that no alarm occurs.
- (c) Check that keys on the control panel can be operated.

6.2 MACHINE CONTROL STATION (Cent'd)

6.2.2.3 14" COLOR GRAPHIC CRT UNIT (MODEL TX1424AD)

(1) Removal

- (a) Check that AC input power is not supplied [the SOURCE indication lamp (green) of the power unit is off], then pull out the cable connected to CNB of model JANCD-FC905.
- (b) Pull out the 200VAC cable connected to CRT.
- (c) Loosen the mounting screws and remove CRT from the control panel.

(2) Installation

- (a) Check the model and REV number of the replacement module for consistency.
- (b) Insert the cable to the original position.**
- (c) Install CRT on the panel.

(3) Checking Functions After Replacement

- (a) Check that **+5V, +12V, and +24V outputs** are not shorted due to overloading.
- (b) Apply the first power and second power again and check that no alarm occurs.
- (c) Check that the brightness and contrast of the CRT are normal.

6.2.2.4 KEYBOARD UNIT (MODEL DF8203921)

(1) Removal

- (a) Check that AC input power is not supplied [the SOURCE indication lamp (green) of the power unit is off], then pull out the cable connected to CNA of model JANCD-FC905.
- (b) Pull out the CNB cable connected to model JANCD-FC951.
- (c) Loosen the mounting screws and remove the keyboard from the control panel.

(2) Installation

- (a) Check the model and REV number of the replacement module for consistency.
- (b) Install the keyboard on the control panel.
- (c) Insert all the cables into the original positions.

(3) Checking Functions After Replacement

- (a) Check that +5V, +12V, and +24V outputs are not shorted due to overloading.
- (b) Apply the first power and second power again and check that no alarm occurs.
- (c) Check that keys on the control panel can be operated and the buzzer sounds.
- (d) Check that CRT OFF indication lamp is turned on and off by operating the CRT OFF key.



7. SETTING AND ADJUSTMENT OF EACH MODULE

This section explains setting and adjustment of each module. Perform setting and adjustment of a module according to the explanation given.

CONTENTS

7. SETTING AND ADJUSTMENT OF EACH MODULE	197
--	-----

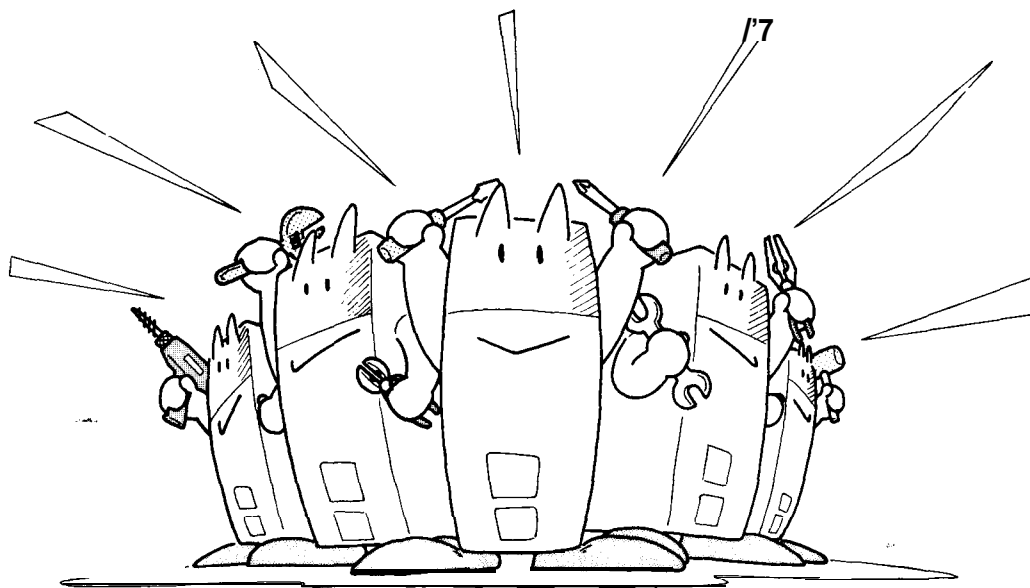

a

7. SETTING AND ADJUSTMENT OF EACH MODULE (Cent'd)

- Model JANCD-FCI 00C

Sw1 : Switch for selecting 9" CRT or EL display (EL)

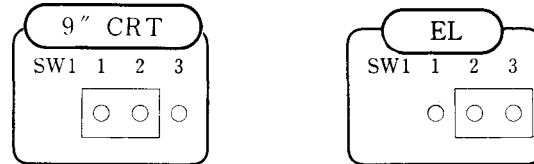

- Model JANCD-FC200

Sw1 : System number switch (16-position rotary switch)

Sw1 [0]: Normal operation mode
 [1]: End user parameter than ge mode
 [4]: Ladder edit mode

Note SW1 [2], [3], and [5] to [F] are used only for maintenance. Only YASKAWA service personnel must use these switches.

- Model JANCD-FC230B or FC260

SW1 , SW2: Switches for selecting the panel and external switches for-apply-ing power

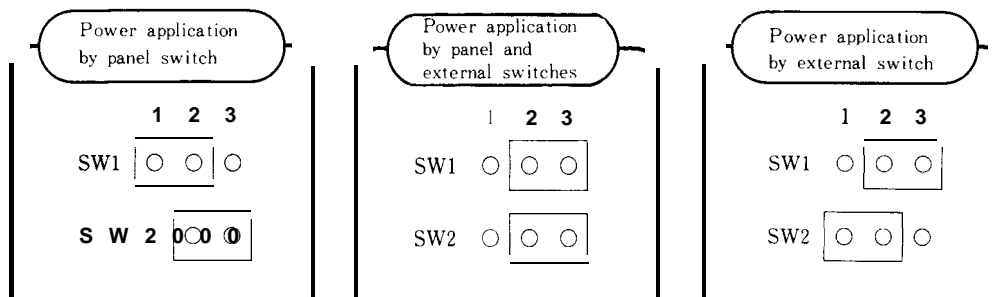

- Model JANCD-FC31 O-1 (-2) /FC260

D/A voltage adjustment VR: Adjusted at the factory before delivery. Readjustment is unnecessary.

VR1: First spindle gain adjustment
 VR2: First spindle zero adjustment
 (VR3: Second spindle gain adjustment).
 (VR4: Second spindle zero adjustment)

.Model JANCD-FC400

Sw1 : System number switch (16-position rotary switch)

SW1[0]: Normal operation mode

When power is applied, the system is started up in synchronization with NC and an application program (index " 1 ") is executed immediately.

[11]: NC built-in program development mode

When power is applied, the system is started up in synchronization with NC and the screen of application program development mode is displayed.

[2]: Stand-alone execution mode

When power is applied, ACGC is started up singly and an application program (index " 1") is executed immediately.

[41]: Stand-alone program development mode

When power is applied, ACGC is started up singly and the screen of application program development mode is displayed.

Note

SW [3], and [5] to [F] are used only for maintenance. Only YASKAWA service personnel must use these switches.

7. SETTING AND ADJUSTMENT OF EACH MODULE (Cent'd)

.Model JAN CD-FC800

(1) SW1: I/O address selection switch

I/O-ADDRESS		
SW1 NON	0 0	→ Area not selected
1	0 0	→ Area No. 1 selected
2	0 0	→ Area NO. 2 selected
3	0 0	→ Area No. 3 selected
4	0 0	→ Area No. 4 selected
5	0 0	→ Reserved
6	0 0	→ Reserved
7	0 0	→ Reserved

(2) SW2: Logical reverse switch

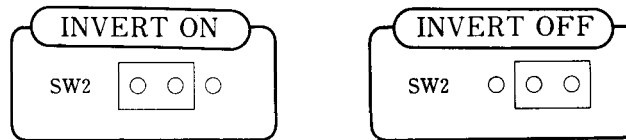

Note This switch activates or deactivates the function for using logical "1" as the logic when contact is closed, regardless of +24 V/0₂₄.

(3) SW3: Terminator

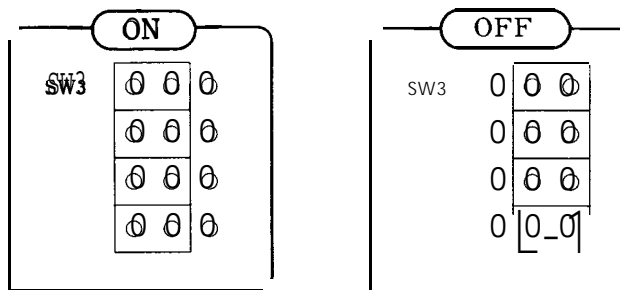

1. For a single remote I/O board used and the last of two or more remote I/O boards used, set the switch to the ON position,

2. In other cases, set the switch to the OFF position.

Note Set the switch so that all positions are set to OFF or ON.

(4) Relationship Between Area Numbers and I/O Address Ports

Input Port				Output Port			
Model JAN CD-FC9		Model JAN CD- FC80C		Model JAN CD- FC903		Model JAN CD- FC800	
Area number	Address port	Area number	Address port	Area number	Address port	Area number	Address port
1 - 1	#1000 } #1007	1	#1000 } #1013	1 - 1	#1100 } #1103	1	#1100 } #1111
1 - 2	#1008 } #1015			1 - 2	Prohibited		
2 - 1	#1016 } #1023	2	#1016 } #1029	2 - 1	#1116 } #1123	2	#1116 } #1127
2 - 2	#1024 } #1031			2 - 2	Prohibited		
3 - 1	#1032 } #1039	3	#1032 } #1045	3 - 1	#1132 } #1135	3	#1132 } #1143
3 - 2	#1040 } #1047			3 - 2	Prohibited		
	None	4	#1048 } #1061		None	4	#1148 } #1159
	None	5	#1064 } #1077		None	5	#1164 } #1175

7

.Model JAN CD-FC900B

SW1, SW2, SW3: Video signal timing adjustment switch

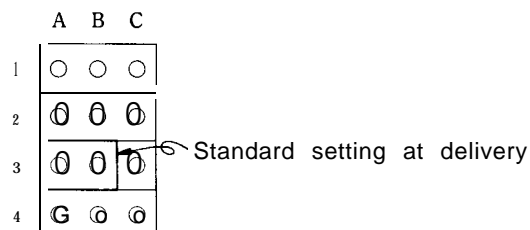

7. SETTING AND ADJUSTMENT OF EACH MODULE (Cent'd)

.Model JANCD-FC903

Sw1 : I/O address selection switch

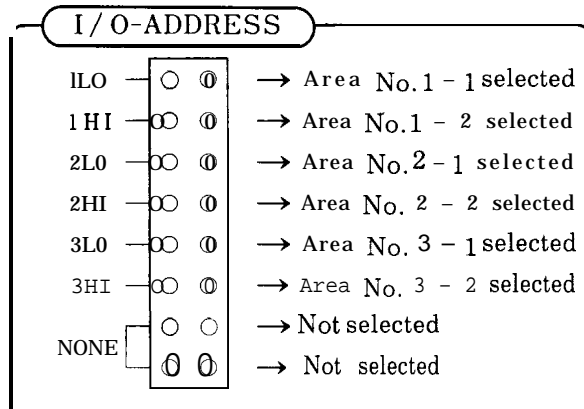

8. OPERATIONS OF FIXED FILES

Fixed files refer to all data files to determine the operation conditions of NC unit, such as parameters and settings.
This section explains the types, displays, and writing of fixed files.
This section should be understood fully for operation.

CONTENTS

8. OPERATIONS OF FIXED FILES	203
8.1 TYPES OF FIXED FILES	204
8.2 DISPLAY AND WRITING OF FIXED FILES	205



8.1 TYPES OF FIXED FILES

Types of fixed files are shown below. The asterisk (*) indicates an option.

- (a) Parameter
 - Parameter
 - Setting
 - Keep memory & sequence parameter
 - Pitch error correction parameter (*)
- (b) Offset
 - Tool offset
 - Work coordinate system shift
- (c) Tool life management data (*)
- (d) Macro program common variables (*)

Note

This unit places various parameters in internal memory. According to their contents, unit operation conditions such as tape codes and rapid feed speeds are determined. Parameters can be displayed at all times, including during automatic operation, regardless of the mode. For the contents of parameters, refer to Section 9 "PARAMETER NUMBERS" of Appendix (TOE -C843-11. 31) of YASNAC i80M Instruction Manual or Appendix (TOE-C843-11. 21) of YASNAC i80L Instruction Manual. For the contents of sequence parameters (pm7000 to pm7099) , refer to the manual issued by the machine manufacturer. Keep memory contains important information for controlling machine sequences, which is held even when power is turned off. Incorrect setting may lead to machine trouble. Great care should be taken according to the manual issued by machine manufacturer.

8.2 DISPLAY AND WRITING OF FIXED FILES

Each fixed file permits screen display, writing, and I/O verification.

Table 8.1 Display, Writing, and I/O Verification of Fixed Files

Item		Display Screen and Write Process	System No. Interlock	I/O Verification Process	System No. Interlock
Parameter	Parameter	Maintenance	Available	Maintenance	Available
	Setting	maintenance, Drive	Not available	Maintenance	Not available
	Keep Memory	Maintenance	Available	Maintenance	Available
	Pitch Error	Maintenance	Available	Maintenance	Available
Offset	Tool Offset	Step	Not available	Maintenance	Not available
	Workpiece Coordinate System	Step	Not available	Maintenance	Not available
Tool Life Management		Step	Not available	Maintenance	Not available
Macro Program Common Variable		Drive	Not available	Maintenance	Not available

Note

System number and interlock have the following rules:

- For writing of parameters and keep memory, system number must be set to 1.
A system number is set by the parameter replacement switch on the control panel or to the value pm0109.
- Setting of parameter replacement switch
OFF: SYSTEM (pm0109 = 0). Normal operation is performed
Writing of parameters is prohibited,
ON: PARAMETER (pm0109 = 1). Selected to write parameters.
Cycle start is prohibited.
- When other than the values shown above is specified, normal operation cannot be guaranteed.
- Effective only when the system number switch on the FC200 board is set to 0.
- System number setting pm0109 must be used as 0, except when writing parameters

8.2 DISPLAY AND WRITING OF FIXED FILES (Cent'd)

(1) Displaying and Writing Fixed File

(a) Parameter Function

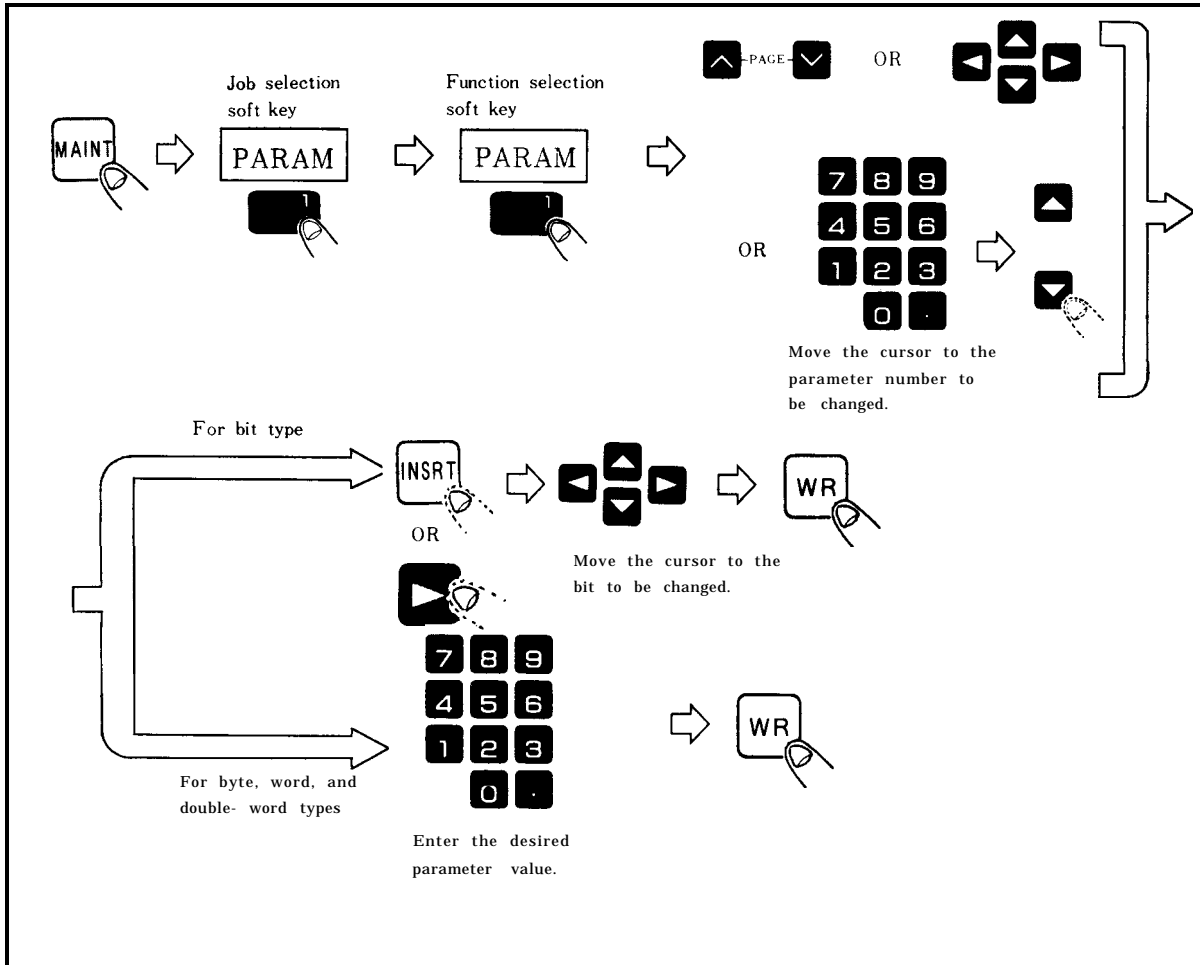

(a) Depress the  key.

(b) Depress the  job selection soft key.

(c) Depress the  function selection soft key.

- (d) Move the cursor to the parameter number to be changed, by one of the following operations:

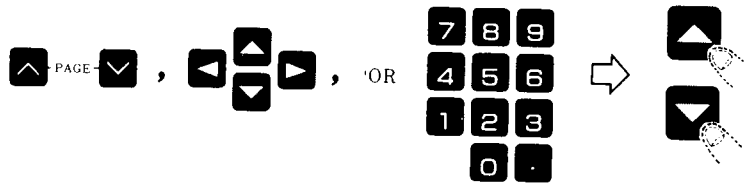

Enter a parameter number.

- (e) Parameter numbers are of bit type, or byte, word, and double-word types, depending on the numbers.

Note For details of parameter numbers, refer to Section 9 "PARAMETER NUMBERS" of Appendix (TOE-C843-11.31) of YASNAC i80M Instruction Manual or Appendix (TOE-C843-11.21) of YASNAC i80L Instruction Manual.

. For bit type — (f)
 .For byte, word, and
 double-word types — (h)

- (f) Depress the  ,  cursor key.
 — The cursor moves to the desired bit position,

8.2 DISPLAY AND WRITING OF FIXED FILES (Cent'd)

(g) Move the cursor to the bit to be changed and depress the  key.

Each time the  key is depressed, the bit is turned ON or OFF.

PARAMETER	MNT								0	1	2	3	4	5	N	1	2	3	4	5
	7	6	5	4	3	2	1	0												
#	0	0	0	0	0	0	0	0	0	0	0	0	0	0	0	0	0	0	0	0
#	0001	0	0	0	0	0	0	0	0	0	0	0	0	0	0	0	0	0	0	0
#	0002	0	0	0	0	0	1	0	0	0	0	0	0	0	0	0	0	0	0	0
#	0003	0	0	0	0	0	0	0	0	0	0	0	0	0	0	0	0	0	0	0
#	0004	0	0	0	0	0	0	1	1	0										6
#	0005	0	0	0	0	0	0	0	0	1										1
#	0006	0	1	0	0	0	0	0	0	0										64
#	0007	0	0	0	1	0	0	0	0	0										16
#	0008	0	0	0	0	0	0	0	0	0										0
#	0009	0	0	0	0	0	0	0	0	0										0

0:OFF 1:ON

MEM
STP
LSK

PARAM ← → A G N IN/OUT

PARAM SETING SEQPRM P. ERR







Fig. 8.1 Bit Type Screen

(h) Enter the desired parameter value.

(i) Depress the  key.

– The parameter value is entered.

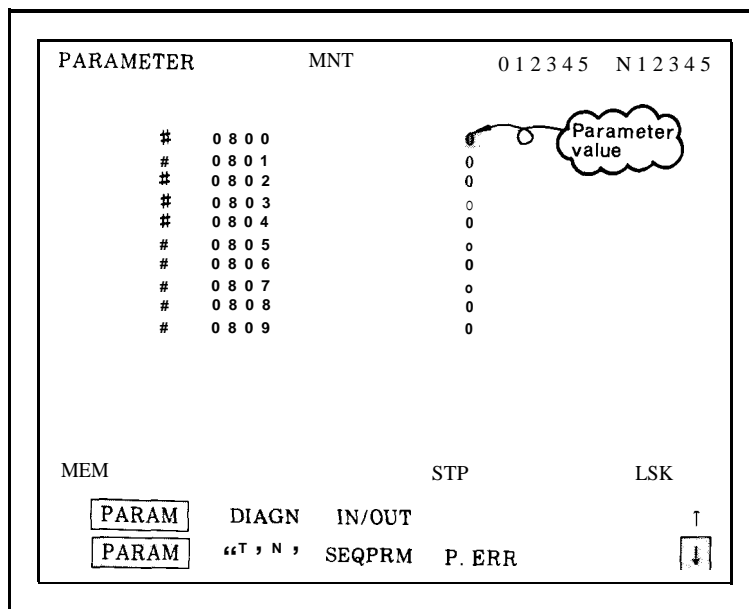
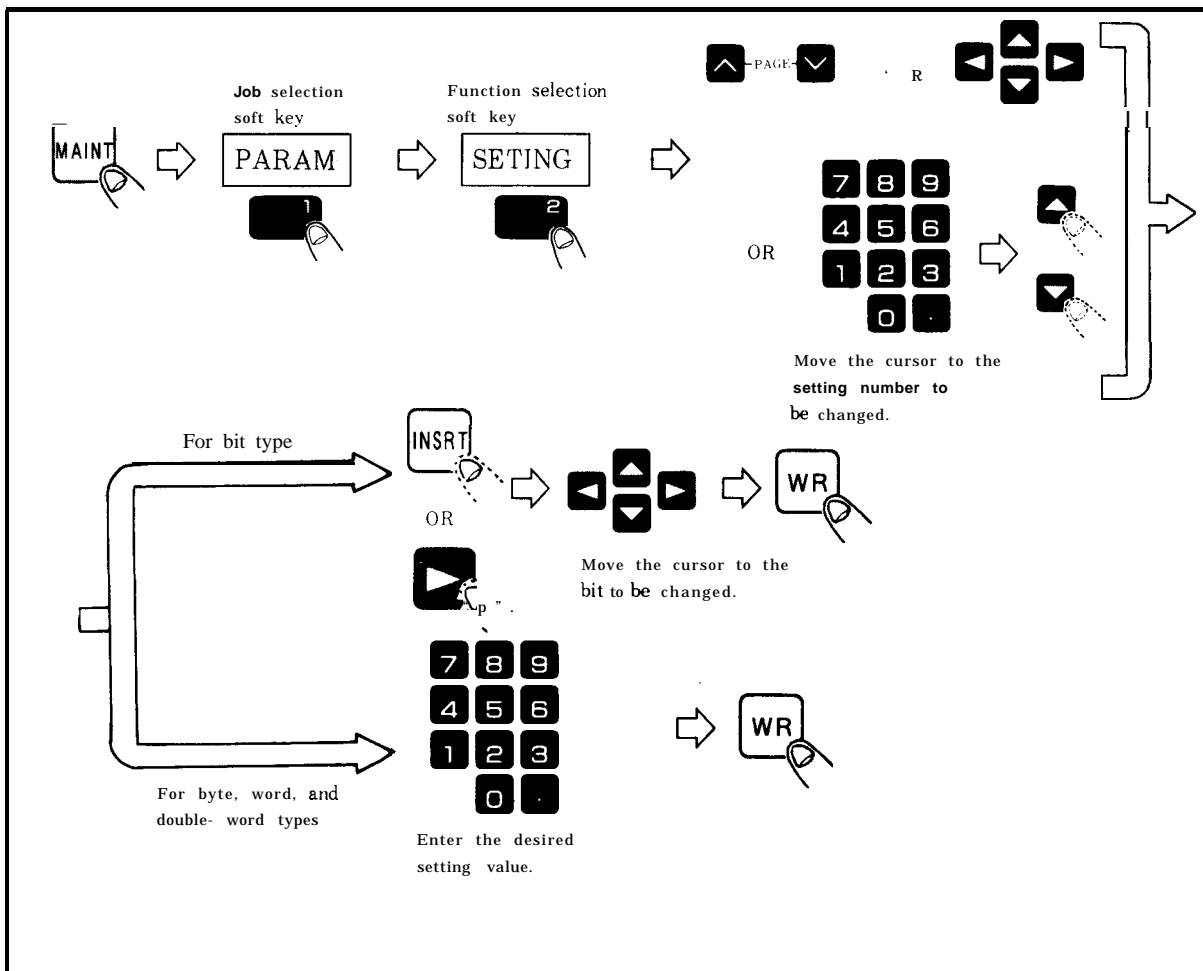



Fig. 8.2 Byte, Word, Double-Word Type Screen

8.2 DISPLAY AND WRITING OF FIXED FILES (Cent'd)

(b) Setting Function



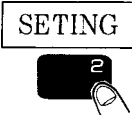

(a) Depress the  key.

(b) Depress the  job selection soft key.

(c) Depress the  function selection soft key,

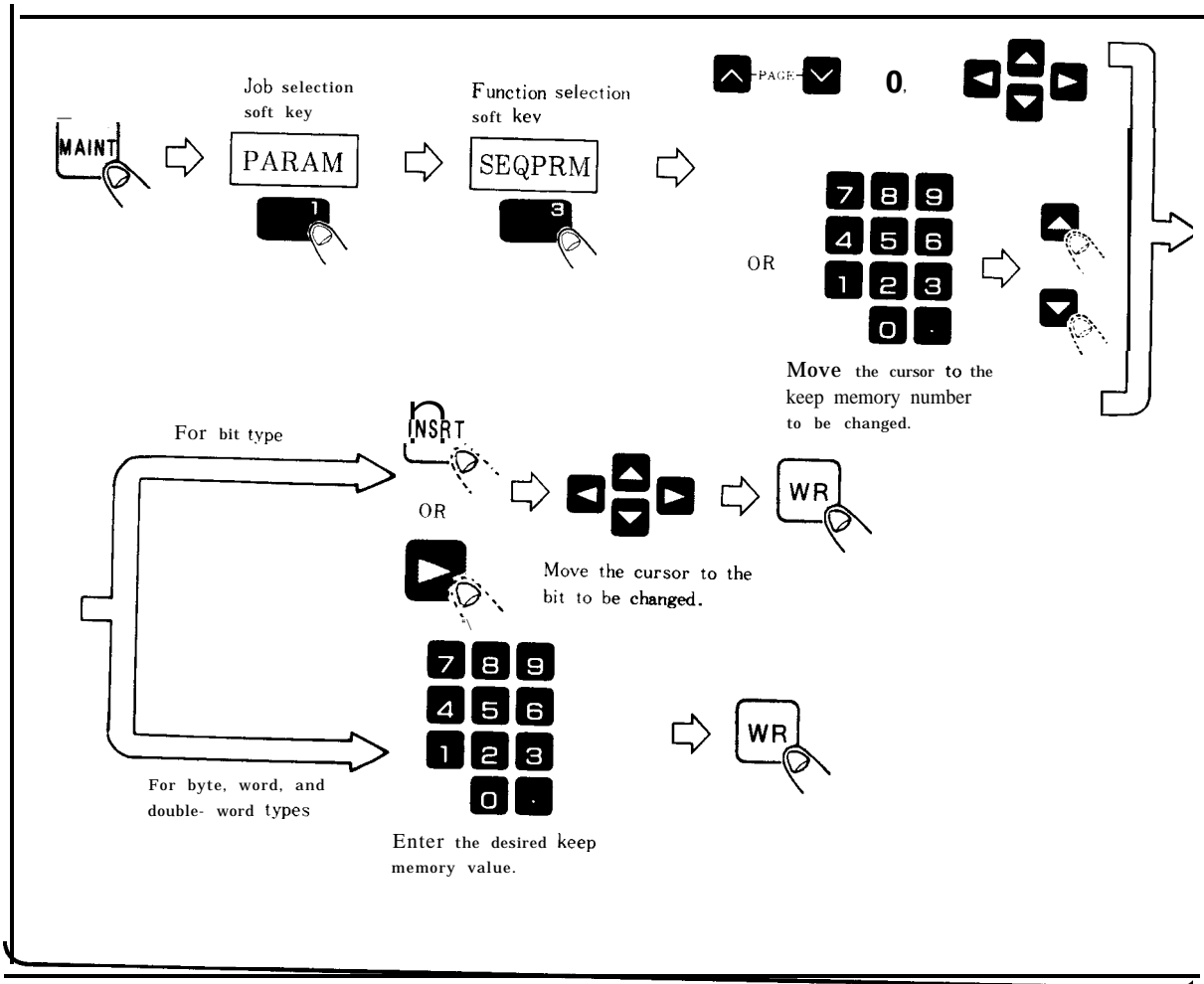
(c) Keep Memory Function



(a) Depress the  key.

(b) Depress the  job selection soft key.

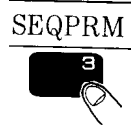
(c) Depress the  function selection soft key.

8.2 DISPLAY AND WRITING OF FIXED FILES (Cent'd)

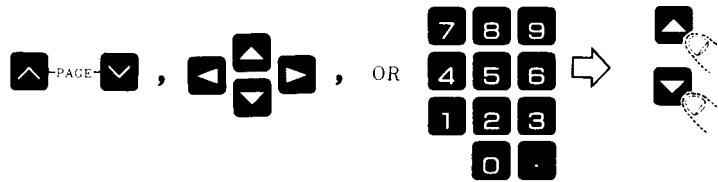

- (d) Move the cursor to the setting number to be changed, by one of the following operations:





Enter a setting number.

- (e) Setting numbers are of bit type, or byte, word, and double-word types, depending on the numbers.

<p>.For bit type — (f) .For byte, word, and double-word types — (h)</p>

- (f) Depress the  or  cursor key.
– The cursor moves to the desired bit position .

- (g) Move the cursor to the bit to be changed and depress the  key.

Each time the  key is depressed, the bit is turned on or off.

- (h) Enter the desired parameter value.

- (i) Depress the  key.

– The setting value is entered.

- (d) Move the cursor to the keep memory number to be changed, by one of the following operations:

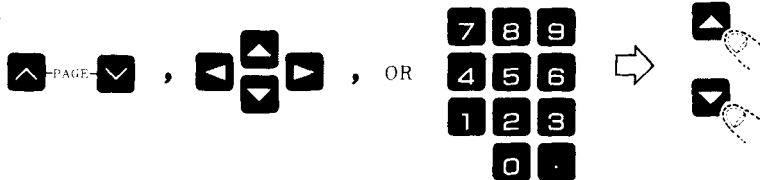



Enter a keep memory number.

- (e) Keep memory numbers are of bit type, or byte, word, and double-word types, depending on the numbers.

- For bit type → (f)
- For byte, word, and double-word types → (h)

- (f) Depress the  key,
 — The cursor moves to the desired bit position.

- (g) Move the cursor to the bit to be changed and depress the  key.

Each time the  key is depressed, the bit is turned on or off.

- (h) Enter the desired keep memory value.

- (i) Depress the  key.

— The keep **memory** value is entered.

8.2 DISPLAY AND WRITING OF FIXED FILES (Cent'd)

(d) Pitch Error Function

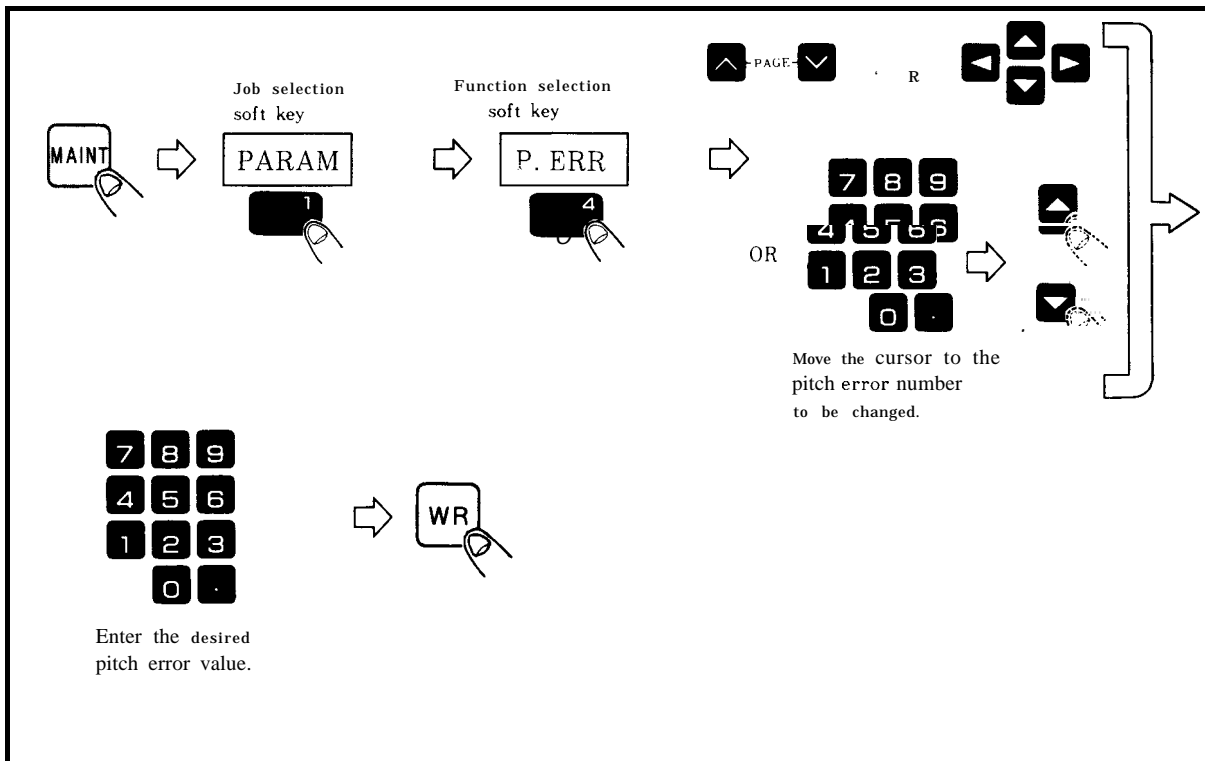

(a) Depress the  key.

(b) Depress the  job selection soft key,

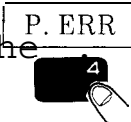
(c) Depress the  function selection soft key.

(d) Move the cursor to the pitch error number to be changed, by one of the following operations:

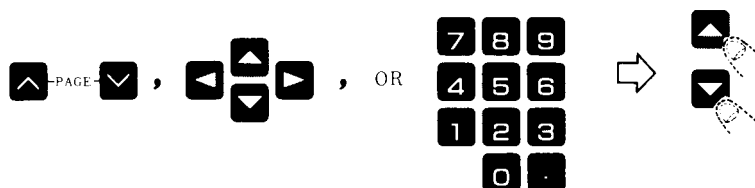

Enter a pitch error number.

(e) Enter the desired pitch error number.

(f) Depress the  key.

– The pitch error number is entered.

YASNAC i80

CNC SYSTEM FOR MACHINE TOOLS

MAINTENANCE MANUAL

TOKYO OFFICE Ohtemachi Bldg, I-6-I Ohtemachi, Chiyoda-ku, Tokyo, 100 Japan
 Phone (03)3284-9111 Telex YASKAWAJ33530 Fax (03)3284-9034
YASKAWA ELECTRIC AMERICA, INC.
 Chicago-Corporate Headquarters 2942 MacArthur Blvd. Northbrook, IL 60062-2028, U.S.A
 Phone (708)291-2340 Fax (708)498-2430
 Chicago-Technical Center 3160 MacArthur Blvd. Northbrook, IL 80082-1917, U.S.A
 Phone (708)291-0411 Fax (708) 291-1018
MOTOMAN INC.
 805 Liberty Lane West Carrollton, OH 45449, U.S.A
 Phone (513) 847-6200 Fax (513) 847-6277
YASKAWA ELÉTRICO DO BRASIL COMÉRCIO LTDA.
 Rua Conde Do Pinhal 8-5, Andar Sala 51 CEP 01501-S50 Paulo-SP, Brash
 Phone (011) 35-1911 Fax (011) 37-7375
YASKAWA ELECTRIC EUROPE GmbH
 Am Kronberger Hang 2, 65824 Schwalbach, Germany
 Phone (49) 6196-569-300 Fax (49) 6196-888-301
Motoman Robotics AB
 Box 130 S-38500, Torsås, Sweden
 Phone 04B6-10575 Fax 0486-11410
Motoman Robotec GmbH
 Kammerfeldstraße 1, 85391 Allershausen, Germany
 Phone 08166-900 Fax 08166-9039
YASKAWA ELECTRIC UK LTD.
 3 Drum Mains Park Orchardton Woods Cumbernauld, Scotland, G68 9LD U.K
 Phone (236)735000 Fax (236)458182
YASKAWA ELECTRIC KOREA CORPORATION
 8th Floor Seoul Center Bldg, 91-1, Sogong-Dong, Chung-ku, Seoul, Korea 100-070
 Phone (02)776-7844 Fax (02)1753-2639
YASKAWA ELECTRIC (SINGAPORE) PTE. LTD.
 Haad Office : CPF Bldg, 79 Robinson Road #13-05, Singapore 0106, SINGAPORE
 Phone 221-7530 Telex (87) 24890 YASKAWA RS Fax 224-5854
 service Center : 221 Henderson Road, # 07-20 Henderson Building Singapore 0315, SINGAPORE
 Phone 276-7407 Fax 276-7406
YATEC ENGINEERING CORPORATION
 Shen Hsiang Tang Sung Chiang Building 10F 146 Sung Chiang Road, Taipei, Taiwan
 Phone (02) 563-0010 Fax (02) 567-4677
SHANGHAI OFFICE Room No 8B Wan Zhong Building 1303 Yan An Road (West), Shanghai 200050, CHINA
 Phone (86) 212-1015 Fax (86) 212-1015
TAIPEI OFFICE Shen Hsiang Tang Sung Chiang Building 10F 146 Sung Chiang Road, Taipei, Taiwan
 Phone (02) 563-0010 Fax (02) 567-4677



YASKAWA

YASKAWA ELECTRIC CORPORATION

TOE-C843-11.2E

© Printed in Japan December 1994 91
590.111



Artisan Technology Group is your source for quality new and certified-used/pre-owned equipment

- FAST SHIPPING AND DELIVERY
- TENS OF THOUSANDS OF IN-STOCK ITEMS
- EQUIPMENT DEMOS
- HUNDREDS OF MANUFACTURERS SUPPORTED
- LEASING/MONTHLY RENTALS
- ITAR CERTIFIED SECURE ASSET SOLUTIONS

SERVICE CENTER REPAIRS

Experienced engineers and technicians on staff at our full-service, in-house repair center

*InstraView*SM REMOTE INSPECTION

Remotely inspect equipment before purchasing with our interactive website at www.instraview.com ↗

WE BUY USED EQUIPMENT

Sell your excess, underutilized, and idle used equipment. We also offer credit for buy-backs and trade-ins. www.artisanng.com/WeBuyEquipment ↗

LOOKING FOR MORE INFORMATION?

Visit us on the web at www.artisanng.com ↗ for more information on price quotations, drivers, technical specifications, manuals, and documentation

Contact us: (888) 88-SOURCE | sales@artisanng.com | www.artisanng.com